

User Manual

Version 1.0 – UMWT4300INT



Evercode™ WT with INTEGRA ASSIST PLUS v4

For use with
ECWT4300



Legal Notices

This document and its contents are proprietary to Parse Biosciences, Inc. (“Parse Biosciences”) and are intended solely for use by its customers in connection with the use of the product(s) described herein and for no other purpose. The products may be used solely FOR RESEARCH PURPOSES, AND MAY NOT BE USED IN ANY DIAGNOSTIC OR THERAPEUTIC USE IN HUMANS OR ANIMALS. This document and its contents shall not be used or distributed for any other purpose and/ or otherwise communicated, disclosed or reproduced in any way whatsoever without the prior written consent of Parse Biosciences.

No rights are granted under this document with respect to any of Parse Biosciences’ intellectual property rights. The license to use of any products described herein is subject to a separate written agreement between Parse Biosciences and the applicable user.

The instructions in this document must be strictly and explicitly followed by qualified and properly trained personnel in order to ensure the proper and safe use of the product(s) described herein. Parse Biosciences shall have no liability for any direct, indirect, consequential or incidental damages arising out of any failure to use the product(s) in strict compliance with the terms herein.

This document may contain references to third-party sources of information, hardware or software, products, or services and/ or third-party web sites (collectively “Third Party Information”). Parse Biosciences does not control, and is not responsible for, any Third Party Information. The inclusion of Third Party Information in this document does not imply endorsement by Parse Biosciences of the Third Party Information or the third party in any way.

The product(s) described in this document are provided for one-time use by the purchaser and may not be re-used, refurbished or resold. In addition, such product(s) may not be altered, changed or modified by anyone other than Parse Biosciences and its authorized agents, and Parse Biosciences will not be liable for any such alterations, changes or modifications.

Patents pending in the U.S. and other countries.

Patent information about the product(s) described herein can be found at:

<https://www.parsebiosciences.com/patents/>

Table of Contents

Overview	5
Workflow	5
Important Guidelines	9
Parse Reagents.....	16
Parse-Provided Equipment	19
INTEGRA Components.....	20
Consumables and Reagents	21
Equipment	24
Reading and Understanding Visuals and Diagrams	26
Section 1: Automation Setup & In Situ Barcoding	30
1.1. Sample Normalization.....	30
1.2. Reagents Preparation.....	39
1.3. Round 1, Round 2, Round 3 Plate Loading and Pooling	46
1.4. Lysate Creation	62
Section 2: cDNA Capture and Amplification.....	66
2.1. Reagents Plating.....	66
2.2. cDNA Capture.....	70
2.3. cDNA-Bound Bead Wash	75
2.4. Master Mixes Preparation.....	78
2.5. Template Switch and cDNA Amplification	83
2.6. Post-Amplification Purification	90

2.7. cDNA Quantification	94
Section 3: Sequencing Library Preparation.....	95
3.0. cDNA Normalization (Optional)	95
3.1. SPRI Bead Plating	101
3.2. Fragmentation Mix Creation and Plating.....	104
3.3. Fragmentation Mix Addition and Post-Fragmentation SPRI Cleanup	108
3.4. Ligation Mix Creation and Plating	113
3.5. Ligation Master Mix Addition and Post-Ligation SPRI Cleanup	116
3.6. Barcoding Round 4	120
3.7. Library Amp Mix Addition and Size Selection	124
3.8. Sequencing Library Quantification.....	129
Appendices	130
Appendix A Sublibrary Gen Table	130
Appendix B: Sequencing Information	131
Appendix C: Pipetting Programs	134
Appendix D: Troubleshooting	159
Appendix E: Revision History.....	160
Appendix F: Acknowledgements	161

Overview

Workflow

The Evercode combinatorial barcoding workflow is compatible with the INTEGRA ASSIST PLUS to enable large-scale single cell RNA-Seq experiments through a robust, semi-automated process.

The Evercode WT v4 kit can profile up to 100,000 cells/nuclei across up to 48 different biological samples or experimental conditions. Evercode Fixation kits first fix and permeabilize cells/nuclei so they act as individual reaction compartments. Through four rounds of barcoding, the transcriptome of each fixed cell/nuclei is uniquely labeled. The four rounds of barcoding can yield a very large number of possible barcode combinations which is more than sufficient to uniquely label up to 100,000 cells/nuclei while avoiding doublets. After sequencing, the Parse Biosciences Analysis Pipeline assigns reads with the same four barcode combinations to a single cell/nuclei.

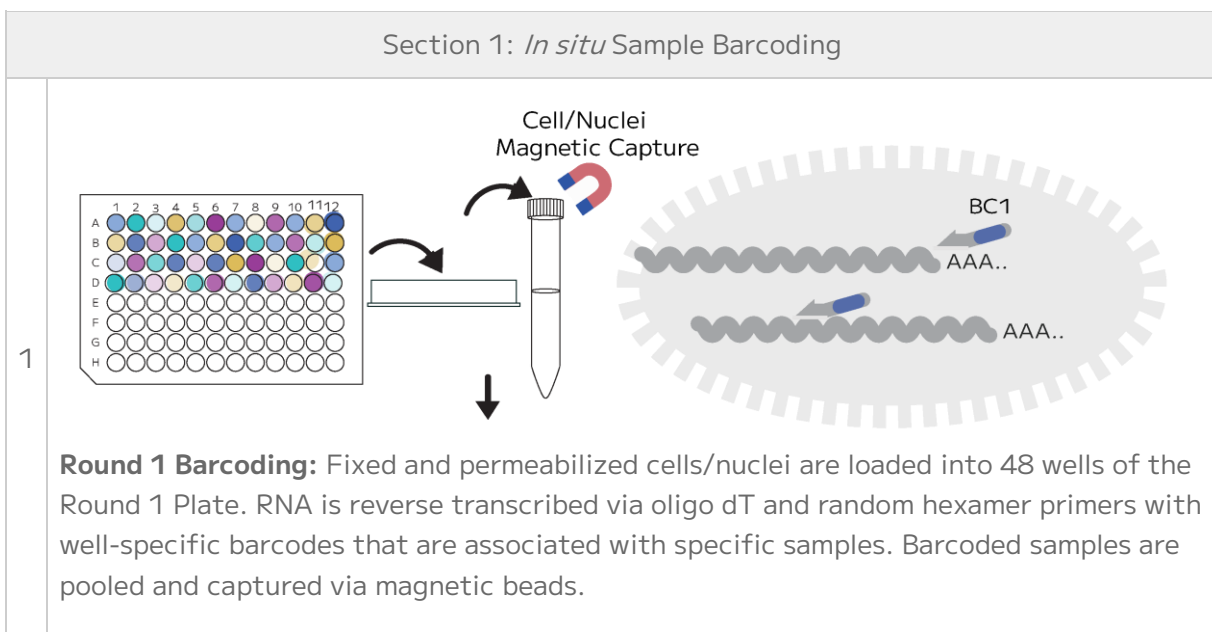

Section 1: *In situ* Sample Barcoding

2

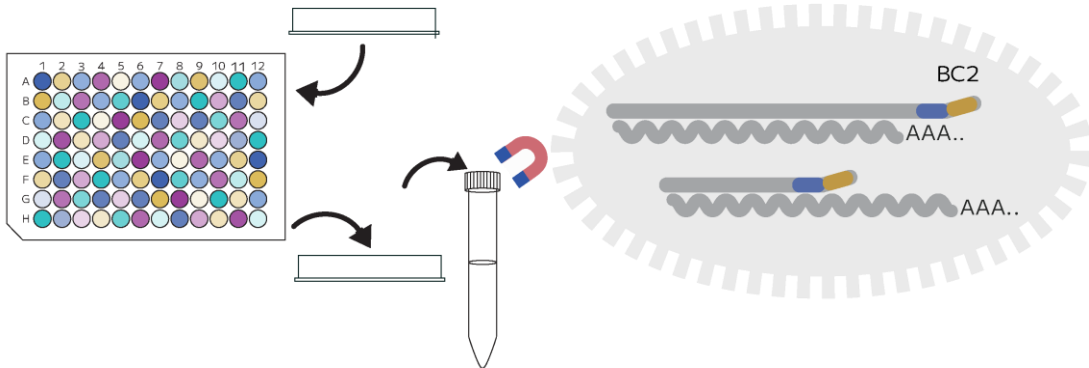

Round 2 Barcoding: The pooled cells/nuclei are loaded into the Round 2 Plate. An adapter with a well-specific barcode is ligated to the first barcode. Cells/nuclei are pooled and then captured via magnet.

3

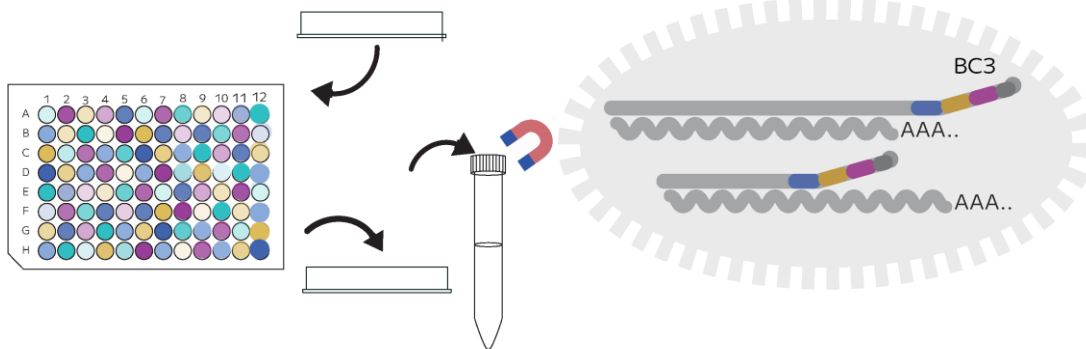

Round 3 Barcoding: The cells/nuclei are pooled and loaded into the Round 3 Plate. A third barcode is ligated to the cDNA, which also contains an Illumina TruSeq Read 2 sequence, and biotin. Cells/nuclei are pooled and then captured via magnet.

4

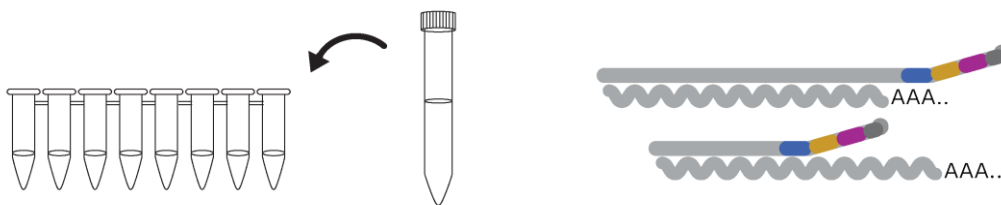

Lysis and Sublibrary Generation: Cells/nuclei are split across 8 sublibraries and lysed.

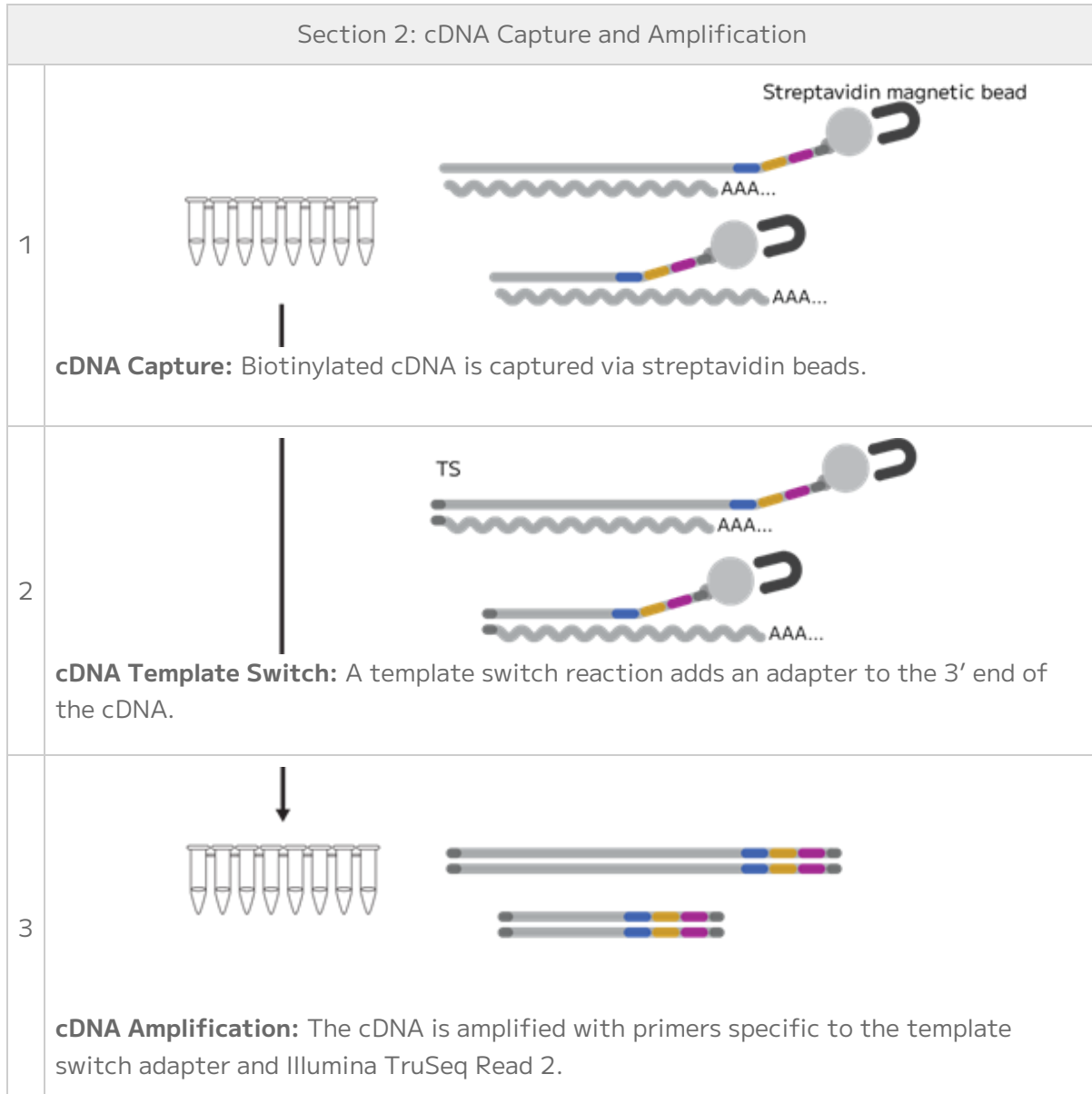

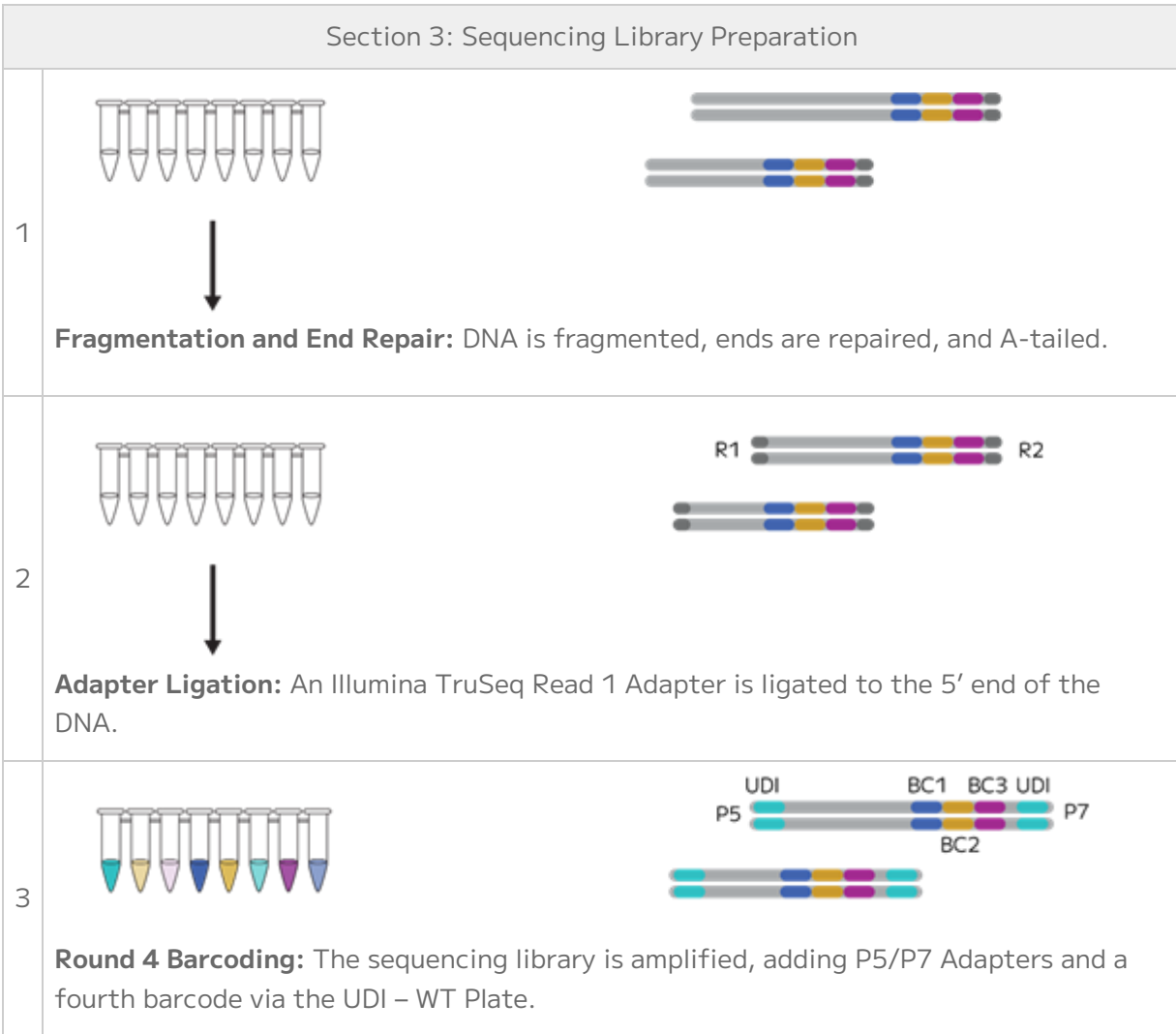

Important Guidelines

The following guidelines provide additional information to obtain optimal performance with the Evercode WT v4 with INTEGRA ASSIST PLUS barcoding workflow.

For further information on the experimental or automation workflow, please contact support@parsebiosciences.com. Please contact support-us@integra-biosciences.com for any questions regarding the INTEGRA ASSIST PLUS instrument.

Sample Input

- This protocol begins with cells or nuclei previously fixed with an Evercode Cell Fixation v4 or Evercode Nuclei Fixation v4 kit.
- Samples fixed with the Standard Fixation and the Low Input Fixation kits are fully compatible with the INTEGRA automated barcoding workflow.
- Even if samples were counted before freezing, we strongly recommend counting cells/nuclei again after thawing to account for any changes in cell/nuclei concentration during storage and freeze/thaw. Typically, a 5-15% decrease in concentration after thawing should be expected. These counts are used to determine how cells/nuclei are loaded in the Round 1 Plate, and counting accuracy at this stage is critical to recover the desired number of cells/nuclei following barcoding.
- When planning on processing many fixed samples, we recommend setting aside a small "counting aliquot" of each sample at the end of fixation. These counting aliquots can be counted the day prior to starting Section 1 of any Evercode assay kit. The Evercode Fixation User Guides outline recommendations for generating aliquots. Because aliquots have undergone a similar storage time and a freeze/thaw, cell/nuclei counts from these aliquots will be more representative than using counts from immediately after fixation.
- Aliquots should be thawed in a water bath set to 37°C in sets of 2-4 and counted with a hemocytometer or alternative counting device. Cell/nuclei counts should be recorded in the Sample Loading Table, and any remaining cell/nuclei material in the thawed counting aliquot should be discarded.
- Once fixed samples have been thawed, they should not be refrozen.
- On the Assist Plus samples will be diluted into a dilution plate prior to Round 1 Barcoding. The Sample Loading Table will recommend the appropriate volume of dilution buffer needed to achieve the correct cell concentration in the required volume. If the required "Number of Sample Dilution Tubes" is greater than 1, three additional dilution buffer tubes for highly concentrated samples can be purchased as a Sample Dilution

Accessory Kit (PN ECAC3901). This kit is included in the initial INTEGRA bundle, but will need to be separately purchased for subsequent orders.

Low Input Fixation Sample Input

- Samples fixed with the Low Input Fixation Workflow can be uploaded after cell/nuclei capture. Low Input samples are prepared manually up to step 1.1.12 of the manual [Evercode WT v4 user guide](#). The diluted low input fixed samples can then enter the Integra automated barcoding workflow at step 1.3.5b in place of the Diluted Sample Plate in this user guide.

Cell/Nuclei Counting and Quality Assessment

- We recommend a hemocytometer for counting, but alternative counting devices can also be used. If possible, validate counts from alternative devices against a hemocytometer when using Evercode kits for the first time.
- We suggest saving images of cells/nuclei at each counting step. 20x and 40x magnification images provide the most useful information.
- To assess sample quality, we recommend using viability stains like trypan blue or acridine orange and propidium iodide (AO/PI).
- Examples of trypan blue stained fixed cells are shown below. High quality fixed samples have single distinct cells/nuclei with <5% cell aggregation and no debris. Higher levels of aggregation will lead to elevated doublets after sequencing. When quantifying fixed samples, it is critical to avoid counting cell debris to avoid overestimating the number of cells/nuclei.

High Quality Sample



Aggregation



Debris

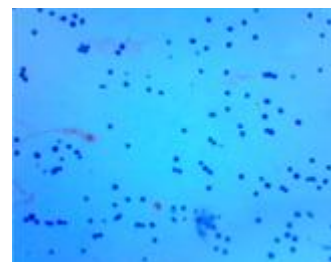

Example trypan blue stained fixed cells.

Avoiding RNase Contamination

- Take standard precautions to avoid introducing RNases into samples or reagents throughout the workflow. Always wear proper laboratory gloves and use aseptic technique.
- Although RNases are not inactivated by ethanol or isopropanol, they are inactivated by products such as RNaseZap™ RNase Decontamination Solution (Thermo Fisher Scientific®). These can be sprayed on benchtops and pipettes. The Assist Plus Base Unit and hardware can also be wiped down with RNase Zap to inactivate RNases.
- Low retention, filtered pipette tips should be used to reduce RNase contamination from pipettes.

Sample Loading Table

- Ensure that the Parse Biosciences Evercode WT v4 INTEGRA Sample Loading Table being used is the most up-to-date version. The Sample Loading Table can be downloaded from the Parse Biosciences Customer Support Suite. Customer log-in is required to access the Sample Loading Table.
- The Parse Biosciences Evercode WT v4 INTEGRA Sample Loading Table should be completed before starting the experiment.
- If the table isn't working as expected, ensure that Macros are enabled in the Sample Loading Table. Be sure to only edit the colored cells in the table to avoid disturbing any calculations.
- In the unlikely event that samples are not concentrated enough according to the Sample Loading Table (Excel spreadsheet), choose to either:
 - Decrease the "Max number barcoded cells" until the Sample Loading Table no longer gives an error. This will maintain the desired final library proportion between samples but barcode fewer total cells/nuclei.
 - Proceed as-is. The INTEGRA pipette will dispense the highest possible number of cells based on the existing concentration. This may lead to reduced library yields for samples with particularly low concentrations.

Indexing Primers

- The Evercode WT v4 kit requires the UDI Plate - WT. The UDI Plate - WT box is included in the INTEGRA bundles but will need to be separately purchased if necessary for subsequent orders.

- The UDI Plate - WT is a 96-well plate containing 48 unique dual indexing (UDI) primers. Each well is a single-use reaction sufficient for one Barcoding Round 4 PCR reaction for a single sublibrary. Thus, the UDI Plate - WT can be used for multiple Evercode kits.
- The UDI Plates are sealed with a pierceable foil to minimize cross-contamination. The plate seal should be wiped with 70% ethanol and pierced with a new pipette tip immediately prior to use. Avoid splashing or mixing the liquid between individual wells. Once a well has been used, it should not be resealed or reused.
- We recommend selecting UDIs column-wise from left to right (starting with indices 1-8). UDI sequences can be found in Appendix B.

Plate Sealing

- When sealing or unsealing 96 well plates, do not splash liquid onto the PCR plate seal or between wells. Securing plates in PCR tube racks will minimize this occurrence.
- PCR plate seals may be difficult to remove. Carefully peel off the PCR plate seal while applying downward pressure on the edges of the plate to keep it in the PCR plate rack. Avoid touching the top of the open wells.

Sample Concentrations

- For an Evercode WT v4 kit, samples can be pre-diluted with Sample Dilution Buffer to a more appropriate working range of 520-3,500 cells/nuclei per μL prior to Sample Dilution on the ASSIST PLUS.
- On the Assist Plus, samples will be diluted with Sample Dilution Buffer to the desired concentration based on the Sample Loading Table.
- For each sample we recommend preparing a 20 μL post-fixation counting aliquot and two 30-50 μL post-fixation sample aliquots. Prior to aliquoting, the samples should be thoroughly resuspended. The counting aliquot may be thawed in advance of the barcoding day to evaluate post-thaw cell recovery. The cell/nuclei loss observed in this aliquot is expected to closely reflect that of the sample aliquots. Concentrations measured from the counting aliquot can then be used to update the Sample Loading Table accordingly.
- If the sample stock concentrations are too high the Sample Loading Table may indicate that more than 1 tube of Sample Dilution Buffer is needed. Additional Sample Dilution Buffer can be purchased in the Dilution Accessory Box (Parse PN ECAC3901) before starting the barcoding workflow.

- The input format for samples into Sample Dilution is a 96-well plate format. If samples have been frozen in 1.5 mL Protein LoBind Tubes, they will need to be transferred to a LoBind 96-well plate on the day of Barcoding. Label this plate as the Sample Plate.

Thermochromic PCR Cold Block

- The Thermochromic PCR Cold Block changes color from dark purple to bright pink (too warm) when the block temperature exceeds 7°C. If greater than 30% of the block is bright pink, replace the Thermochromic PCR Cold Block with a fully frozen dark purple block.
- To maintain optimal performance and minimize temperature fluctuations, store the Thermochromic PCR Cold Blocks in a -20°C freezer when not in use. The blocks should be stored upside down to prevent warping.
- The Thermochromic PCR Cold Block Riser needs to be installed in the Thermochromic PCR Cold Block prior to use as illustrated below. The Riser does not need to be removed when freezing.

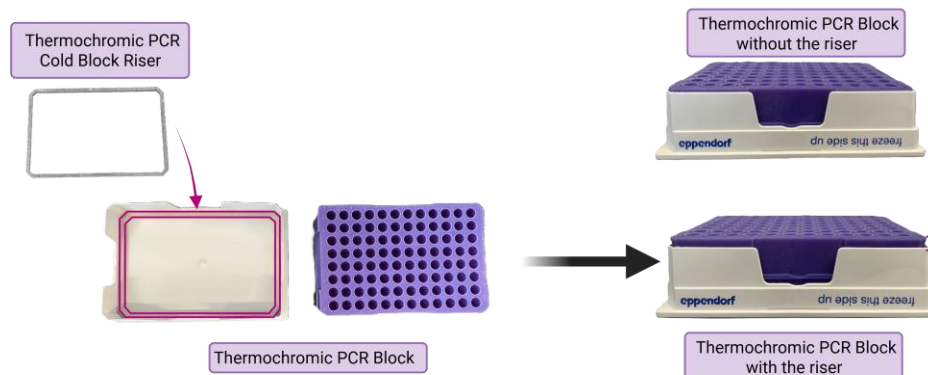

Note: Uneven freezing of the liquid inside the Thermochromic PCR Block can cause slanting of the cooling position. The Thermochromic PCR Cold Block Riser reduces the variability caused by the freezing process. If the PCR Cold Block riser is not used, there will be extra liquid left in the wells of the PCR plate during aspiration steps.

- Tip pinching may occur when using a fully frozen Thermochromic PCR Cold Block for a plate pooling step. To minimize tip pinching, a fully frozen block should be warmed slightly by a few degrees by leaving it at room temperature for 10 minutes before using it on the INTEGRA ASSIST PLUS Deck.
- To ensure a secure positioning within the Thermochromic PCR Cold Block, apply firm pressure on the PCR plates until they are securely seated. Avoid touching the top of the open wells.

Bases and Reservoirs

- Both the 300 mL Reservoir Base and the 8-Row Polystyrene Reservoir are consumables that must be purchased from INTEGRA. The 300 mL Reservoir Base is designed to securely hold the 8-Row Reservoir in place during use.

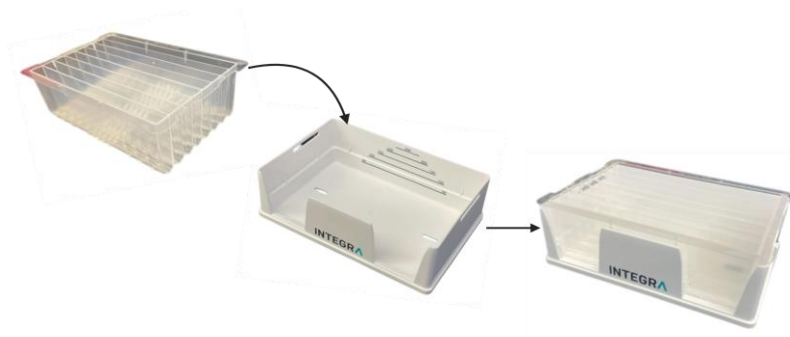

Cooling Adapter Bases

- To assemble the Cooling Adapter Bases place the Fixation 8 Row Reservoir Adapter or the Fixation Deep Well Adapter on top of the Cooling Adapter Base as shown in the figures below.

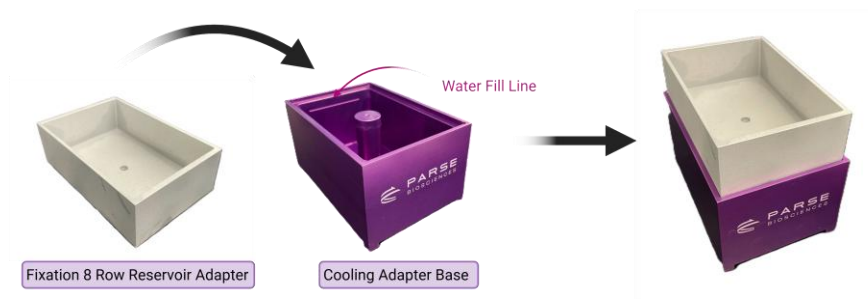

Fixation 8 Row Reservoir Adapter with Cooling Adapter Base.

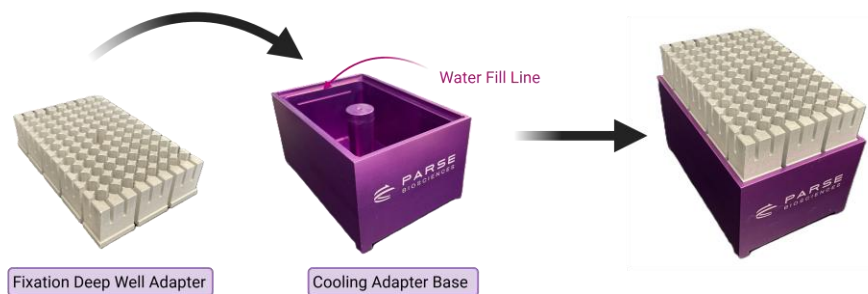

Fixation Deep Well Adapter with Cooling Adapter Base.

- Before use, the Cooling Adapter Base should be filled with water and frozen the night before, then thawed at room temperature for at least 10 minutes prior to use. Alternatively, it can be filled with pebble ice immediately before being placed on the Integra Deck.



Note: If the Cooling Adapter Base is filled with water and frozen before use, ensure that the water level does not exceed the water fill line. The water will expand when frozen and the adapter will not fit properly if the base is overfilled.

INTEGRA ASSIST PLUS Pipetting Programs

- Ensure that the VIALAB program is installed on the same Windows computer that will be used to communicate with the D-ONE Pipetting Module.
- Ensure that the Evercode workflow precheck script has been confirmed prior to running the INTEGRA + Parse workflow. This can be done by running the Evercode WT v4 with INTEGRA ASSIST PLUS Precheck Scripts available on the Customer Support Suite.
- Ensure that the .csv worklists generated via the Parse Evercode WT INTEGRA Sample Loading Table ("**CombinedWTWorksheet_YYMMDD_HHMMSS.csv** ") are accessible for upload to the VIALAB program.
- Automated pipetting programs are set up and can be selected using the pipette's user interface. In the INTEGRA + Parse workflow, prompts are built into the programs as checkpoints. When the prompt is followed by a double dash, "--", the program will continue. If the prompt does not contain a double dash, "--", it is followed by another prompt.











Deck Loading

- Always ensure the tip box placed on the deck clicks when put into place. Remove the tip box lid prior to starting the program.
- To prevent malfunctions during the procedure, ensure that all unnecessary labware is cleared from the deck before initiating a new program on the INTEGRA ASSIST PLUS.





Parse Reagents

The Evercode WT v4 kit includes the following boxes. Safety Data Sheets for these reagents can be provided upon request



-20°C Reagents Store -20°C, PN WT400

LABEL	ITEM	PN	FORMAT	QTY
	Round 1 Plate	WT101	Green semi-skirted 96 well plate	1
	Round 2 Plate v4	WT142	Blue semi-skirted 96 well plate	1
	Round 3 Plate	WT103	Yellow semi-skirted 96 well plate	1
	Bead Prep Buffer	WT136	2 mL tube	1
	Barcoding Buffer	WT137	15 mL bottle	1
	Round 1 Stop Mix	WT138	2 mL tube	1
	Ligation Enzyme	WT140	1.5 mL tube	1
	Sample Dilution Buffer	WT105	2 mL tube	1
	Ligation Buffer	WT134	15 mL bottle	1
	Round 2 Stop Mix	WT139	2 mL tube	1
	Final Stop Mix	WT141	5 mL tube	1

LABEL	ITEM	PN	FORMAT	QTY
	Pre-Lysis Dilution Buffer	WT112	2 mL tube	1
	Pre-Lysis Wash Buffer	WT110	5 mL tube	1
	Lysis Solution	WT146	1.5 mL tube	1
	Lysis Enzyme	WT113	1.5 mL tube	1
	Wash Buffer A	WT143	5 mL tube	1
	Bead Wash Buffer	WT114	5 mL tube	1
	Binding Buffer	WT118	1.5 mL tube	1
	Wash Buffer B	WT144	5 mL tube	1
	Template Switch Buffer	WT148	1.5 mL tube	1
	Template Switch Enzyme	WT121	1.5 mL tube	1
	Template Switch Primer	WT122	1.5 mL tube	1
	PCR Additive	WT150	1.5 mL tube	1
	cDNA Amp Mix	WT123	1.5 mL tube	1
	cDNA Amp Primers	WT124	1.5 mL tube	1
	Fragm/End Prep Buffer	WT125	1.5 mL tube	1

LABEL	ITEM	PN	FORMAT	QTY
	Fragm/End Prep Enzymes	WT126	1.5 mL tube	1
	Ligation Adapter	WT127	1.5 mL tube	1
	Adapter Ligation Buffer	WT128	1.5 mL tube	1
	Adapter Ligation Enzyme	WT129	1.5 mL tube	1
	Library Amp Mix	WT130	1.5 mL tube	1

4°C Reagents. Store 4°C, PN WT500

LABEL	ITEM	PN	FORMAT	QTY
	Sample Binding Beads	WT135	0.5 mL tube	1
	Streptavidin Beads	WT203	1.5 mL tube	1

-20°C Sample Dilution Accessory Kit* Store at -20°C, PN ECAC3901

LABEL	ITEM	PN	FORMAT	QTY
	Sample Dilution Buffer	MG105	2 mL tube	3

*The -20°C Sample Dilution Accessory Kit is optional and can be purchased separately if needed to dilute concentrated samples.

Parse-Provided Equipment

The following is a list of equipment provided by Parse Biosciences, required to successfully perform the Evercode workflows on the INTEGRA ASSIST PLUS.

The equipment listed should be stored at -20°C when not in use and taken out when instructed throughout the protocol.

ITEM	PN	QTY	CHECK LIST
Thermochromic PCR Cold Block	NTAC1102	3	<input type="checkbox"/>
Thermochromic PCR Cold Block Riser	NTAC1103	3	<input type="checkbox"/>
Parse Metal Cold Block	NTAC1107	1	<input type="checkbox"/>
Cooling Adapter Base	NTAC1106	1	<input type="checkbox"/>
Self-Standing 8 Row Reservoir Adapter	NTAC1110	1	<input type="checkbox"/>
HEATMAG 8 Row Reservoir Adapter	NTAC1109	1	<input type="checkbox"/>
HEATMAG Cooling Accessory	NTAC1108	1	<input type="checkbox"/>

INTEGRA Components

The following are required INTEGRA components needed to run the Evercode assay on the INTEGRA and should not be substituted.

ITEM	ITEM TYPE	PN	QTY	CHECK LIST
Pipette Communication Module for VIAFLO / VOYAGER Pipettes	Accessory	4222	3	<input type="checkbox"/>
Tip Deck for D-ONE Pipetting Module	Base	4535	1	<input type="checkbox"/>
ASSIST PLUS Labware Pedestal (+24 mm) for D-ONE, portrait, for 10 mL, 25 mL, 100 mL, reservoirs and plates/reservoirs in SLAS/ANSI format (24 mm Labware Pedestal)	Adapter	4551	1	<input type="checkbox"/>
D-ONE Pipetting Module 1-Ch, 5-1250 µL	Pipette	4532	1	<input type="checkbox"/>
VIAFLO Pipette 12-Ch, 300 µL	Pipette	4633	1	<input type="checkbox"/>
VOYAGER Pipette 8-Channel, 5 - 125 µL	Pipette	4722	1	<input type="checkbox"/>
ASSIST PLUS Base Unit	Main	4505	1	<input type="checkbox"/>
Communication/Charging Cable for VIAFLO	Accessory	4226	1	<input type="checkbox"/>
HEATMAG Module	Module	4901	1	<input type="checkbox"/>
96 Well Adapter for HEATMAG module	Adapter	4906	1	<input type="checkbox"/>
300 mL Reservoir Bases	Accessory	6305	1	<input type="checkbox"/>

Consumables and Reagents

The following is a list of consumables and reagents required to successfully perform Parse Evercode workflows on the INTEGRA ASSIST PLUS.

INTEGRA Consumables

ITEM	PN	QTY	CHECK LIST
8 Row Reservoirs, Polypropylene, Pyramid Bottom (a.k.a. Self-Standing 8 Row Reservoir)	6372	2	<input type="checkbox"/>
8 Row Reagent Reservoirs, Polystyrene, standard footprint, with SUREFLO design (a.k.a. 8 Row Reservoir Insert)	6373	1	<input type="checkbox"/>
1250 µL Pipette Tips	6545	1	<input type="checkbox"/>
300 µL Pipette Tips	6535	4	
125 µL Pipette Tips	6565	3	

Other Consumables

ITEM	SUPPLIER	PN	QTY	CHECK LIST
Rigid Plate Strainer (choose an appropriate mesh size for your sample type)	Parse Biosciences	RPS1030 RPS1070 RPS1100	6-pack	<input type="checkbox"/>
1.5 mL Microtube	Genesee Scientific	21-257	6	<input type="checkbox"/>
PCR Strip Tubes	USA Scientific®	1402-4700	8	<input type="checkbox"/>
2 mL Microtubes	Genesee Scientific	21-255	4	<input type="checkbox"/>
twin.tec® Semi-Skirted PCR Plate 96 LoBind® Semi-skirted 96 well plates	Eppendorf®	E951020362	8	<input type="checkbox"/>

ITEM	SUPPLIER	PN	QTY	CHECK LIST
SealPlate®	Excel Scientific	100-SEAL-PLT	as needed	<input type="checkbox"/>
TempPlate Sealing® Foil	USA Scientific	2923-0100	as needed	<input type="checkbox"/>
Pipette Tips RT LTS 20 µL FL 960A/10 RT LTS 200 µL FL 960A/10 RT LTS 1000 µL FL 768A/8	Rainin®	30389226 30389240 30389213	as needed	<input type="checkbox"/>

Reagents

ITEM	SUPPLIER	PN	NOTES	CHECK LIST
UDI Plate - WT	Parse Biosciences	UDI1001	Each 96 well plate contains 48 unique single-use reactions sufficient for multiple Evercode kits (48 sublibraries). UDI Plate - WT can be purchased separately or bundled with Evercode kits.	<input type="checkbox"/>
AMPure® XP Reagent	Beckman Coulter®	A63880 (5 mL) A63881 (60 mL)	Choose one. We do not recommend substituting other magnetic beads.	<input type="checkbox"/>
SPRIselect Reagent	Beckman Coulter	B23317 (5mL) B23318 (60mL)		
KAPA® Pure Beads	Roche®	KK8000 (5 mL) KK8001 (30mL)		
RNaseZap™ RNase Decontamination Solution	Thermo Fisher Scientific®	AM9780	Or equivalent RNase decontamination solution.	<input type="checkbox"/>
Ethyl alcohol, Pure	Sigma-Aldrich®	459844	Or equivalent 100% non-denatured ethanol.	<input type="checkbox"/>
Nuclease-Free Water	Sigma-Aldrich	W4502	Or equivalent nuclease-free water.	<input type="checkbox"/>
Propidium Iodide (PI)	Various Suppliers	Varies	Or alternative fluorescent dyes to assess viability, such as AO/PI, Hoechst, DAPI, Calcein AM, etc.	<input type="checkbox"/>

ITEM	SUPPLIER	PN	NOTES	CHECK LIST
Qubit dsDNA HS (High Sensitivity) Assay Kit	Thermo Fisher Scientific	Q33230 (100 assays) Q33231 (500 assays)	Or equivalent DNA quantifier.	<input type="checkbox"/>
High Sensitivity DNA Kit	Agilent®	5067-4626	Choose one that corresponds to the chosen Bioanalyzer or TapeStation.	<input type="checkbox"/>
High Sensitivity D5000 ScreenTape and Reagents	Agilent	5067-5592 (screen tape) 5067-5593 (sample buffer and ladder)		

Equipment

The following equipment is required to perform the protocol, but are not provided by INTEGRA or by Parse Biosciences. Note that this list does not include standard laboratory equipment, such as freezers.

Equipment

ITEM	SUPPLIER	PN	NOTES	CHECK LIST
Centrifuge with Swinging Bucket Rotors	Various Suppliers	Varies	Compatible with 96 well plates and capable of reaching 4°C.	<input type="checkbox"/>
Microcentrifuge	Various Suppliers	Varies	Compatible with 1.5 mL tubes and PCR 8-strip tubes.	<input type="checkbox"/>
6-Tube Magnetic Separation Rack	New England Biolabs®	S1506S	Or an equivalent magnetic rack for 1.5 mL tubes.	<input type="checkbox"/>
Hemocytometer	Sigma-Aldrich®	Z359629	Or other cell counting devices compatible with fluorescence-based cell counting. We recommend validating alternatives relative to a hemocytometer.	<input type="checkbox"/>
Plate Seal Applicator	Various Suppliers	Varies	Capable of adhering plate sealing films to 96 well plates.	<input type="checkbox"/>
T100 Thermal Cycler	Bio-Rad Laboratories®	1861096	Or an equivalent thermocycler compatible with semi-skirted 96 well plates, 0.2mL PCR tubes with up to 100 µL of sample volume, sample heating and cooling from 4-98°C, and a heated lid capable of 30-105°C.	<input type="checkbox"/>
Water bath	Various Suppliers	Varies	Or equivalent thermomixer or heat block capable of holding temperature at 37°C.	<input type="checkbox"/>
Vortex-Genie 2®	Scientific Industries®	SI-0236	Or alternative vortex and adapter for 96 well plates, or a thermomixer or alternative shaker that can be set to 800-1000 RPM for 30 minutes.	<input type="checkbox"/>
6-inch Platform	Scientific Industries	146-6005-00		
Microplate Foam Insert	Scientific Industries	504-0235-00		
Qubit™ Flex Fluorometer	Thermo Fisher Scientific	Q33327	Or an equivalent fluorometer.	<input type="checkbox"/>

ITEM	SUPPLIER	PN	NOTES	CHECK LIST
2100 Bioanalyzer	Agilent®	G2939BA	Choose one.	<input type="checkbox"/>
4200 TapeStation System	Agilent	G2991BA		

Reading and Understanding Visuals and Diagrams

Understanding the figures in this user manual is essential for accurately interpreting the information presented.

While the figures are different, they share consistent formats, use standardized visual elements and follow common conventions.

There are three types of figures in this manual.

- Photos of the hardware configurations, including tip rack, and Decks A, B, and C.
- Visual representation of Decks A, B, and C where consumable labware, reagents, and samples are placed.
- Diagrams of the pipette illustrating the steps to select the appropriate program.

We recommend reviewing this section and the illustrations throughout the manual to familiarize yourself with the visual language used.

Understanding the Hardware Configurations

The hardware configurations appear at the beginning of each subsection and show how to set up the INTEGRA platform to complete the associated steps. This photo displays the tip racks, Deck A, Deck B, and Deck C. Red arrows indicate the order in which tips are picked up by the INTEGRA platform, and required hardware is highlighted with text boxes.

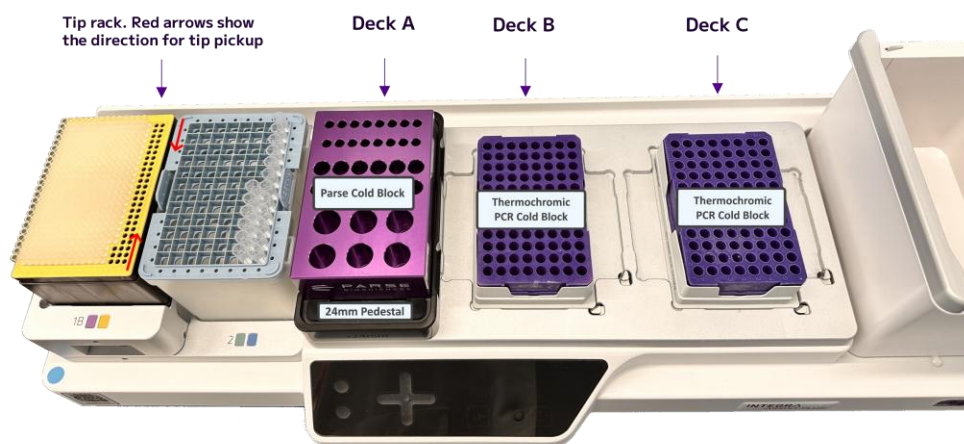

Blocks and Pedestals are hardware components that will be placed or removed as needed throughout the workflow.

Reading and Understanding the Deck Configurations

Each subsection includes multiple deck configurations that illustrate the steps executed by the program. These configurations display the exact placement of reagents and samples on the

decks, list the consumables required at each step, and highlight pipette prompts for manual intervention.

Graphical representation of basins and/or tubes with colored outlines show where specific reagents will be added. Each outline color matches the color of the reagent's label.

Color-coded cues guide the user through actions such as loading, moving, or removing hardware, reagents, and consumables, while also indicating the specific deck locations where these actions should occur.

Letter-coded pipette prompts indicate the specific action the robot is about to perform when initiated. A double dash ("--") at the end of a prompt signifies that all prompts have been entered, and the robot will begin executing the programmed movements immediately after.

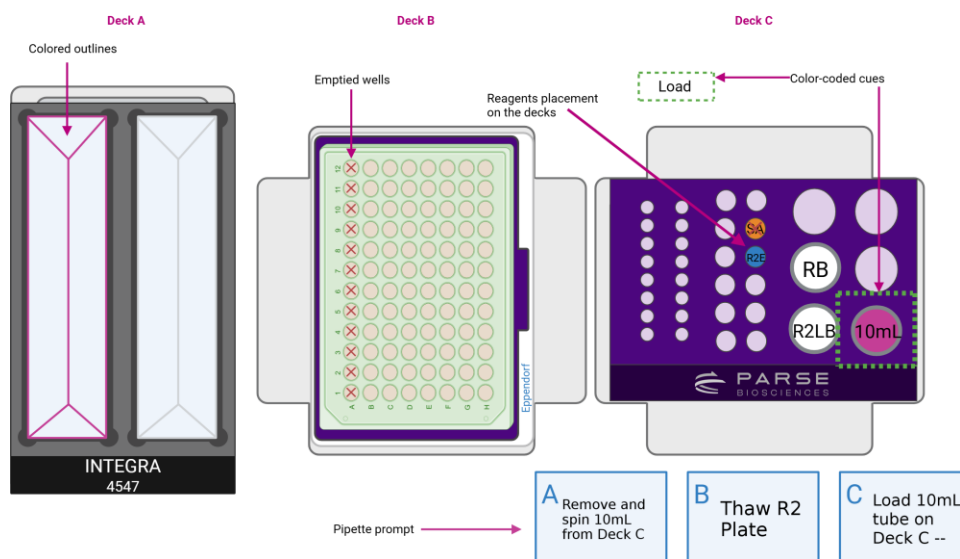

The Parse Metal Cold Block

It is critical to place reagents, samples, and consumables in the correct positions on the Parse Metal Cold Block.

The Parse Metal Cold Block is organized into three main columns, 1, 2 and 3, each containing two sub-columns (left and right) with slots of varying sizes to accommodate different tube types.

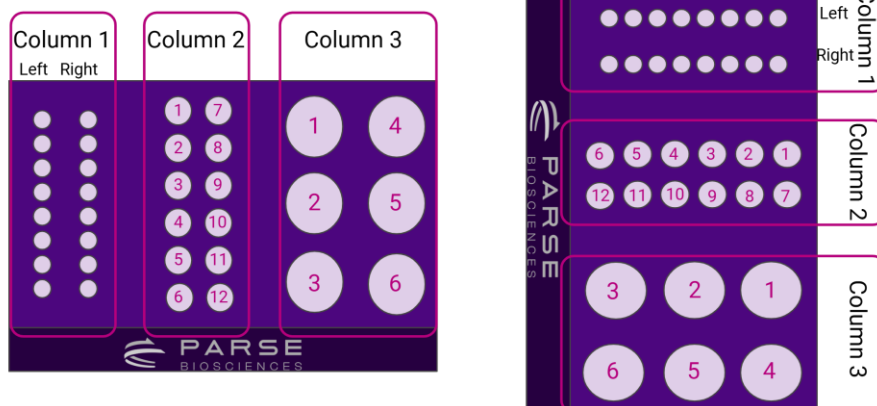

Color-Coded Cues

This workflow is semi-automated and still requires user interaction and input. Prompts will appear on the pipette display, instructing the user to perform tasks such as loading, moving, removing, or replacing hardware, reagents, and consumables, as well as mixing and pipetting specific reagents. In this user guide, each prompt is color-coded and shown in the deck configurations illustrating the required actions. Additional explanatory text accompanies each figure to provide further detail on the steps involved.



- **Load:** Indicates labware and/or reagents that need to be placed or reloaded onto the deck.
- **Remove:** Identifies labware that should be taken off the deck, either for incubation, disposal, or because it is not needed in the upcoming step.
- **Replace:** Highlights labware that has been used and needs to be swapped out for clean or new consumables.
- **Pipette:** Prompts the user to manually dispense reagents into designated basins.
- **Mix:** Instructs the user to mix specific reagents.
- **Move:** Indicates labware that should be relocated between deck positions.

- **X Emptied:** Reminds that the content has been used and the vessel is now empty.



Note: The position of the color-coded cues on top of the figures does not necessarily correspond to the location where the action should be taken.

Pipette Programs Diagram

At various points in the procedure, the user will need to switch pipettes and tip racks. In each subsection, the pipette is pre-programmed to carry out specific tasks defined by a designated script. The correct program must be loaded onto the pipette before beginning each set of steps. A diagram showing the path to load the appropriate program is provided in every subsection.

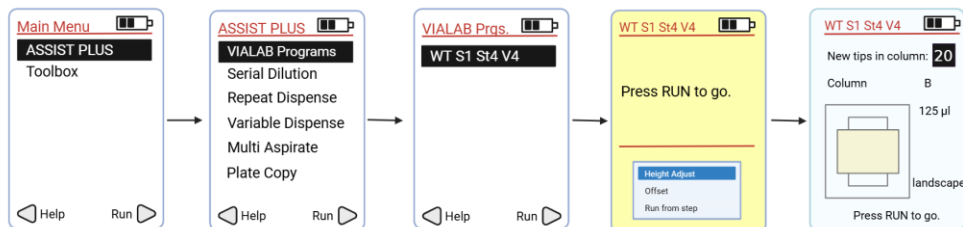

Section 1: Automation Setup & In Situ Barcoding

1.1. Sample Normalization

This section is for Standard Fixed samples only. If using Low Input **Fixed samples, manually capture and dilute the cells. Skip this section and proceed to Section 1.2.**

Prior to setting up the Automation workflow, count the cells/nuclei to assess quality and concentration of the fixed sample(s). Samples should be diluted with Sample Dilution Buffer to the target concentrations listed in the Sample Loading Table.

After adjusting the sample(s) to the recommended dilution range, update the Sample Loading Table, and download the Sample Loading Table macro (Section 1.1.6). This .csv file will be used as reference for allocating the fixed cells/nuclei into the 96-well PCR Dilution Plate, to prepare samples to be loaded into the Barcoding Round 1 Plate. The recommended dilution range for WT is 520-3,500 cells/nuclei per μL .

The program uses the Sample Dilution Buffer on Deck A to normalize fixed samples from plate format on Deck C into an intermediate dilution plate on Deck B.

To normalize samples:

1. If working with standard fixation samples, remove the ● Sample Binding Beads from the 4°C Reagents box. Gently pulse-vortex (1-2 seconds per pulse) or pipette mix the beads until completely resuspended. Observe the beads to confirm they stay in solution for **at least 2-3 minutes** before beginning to settle. Store the ● Sample Binding Beads at room temperature until use.



CRITICAL! If you observe that the Sample Binding Beads are frozen or dried, and settled at the bottom the tube within ~10 seconds after pulse-vortexing, **do not proceed**. Contact your FAS or support@parsebiosciences.com for assistance

2. Cool a centrifuge with swinging bucket rotors to 4°C.
3. Set a water bath to 37°C.
4. Fill an ice bucket with ice.

5. Gather the following components and reagents:

ITEM	SOURCE	QTY	HANDLING AND STORAGE
D-ONE Pipetting Module 1-Ch, 5-1250 μ L	INTEGRA Component	1	
Tip Deck for D-ONE Pipetting Module	INTEGRA Component	1	
125 μ L Tip Rack	INTEGRA	1	
1250 μ L Tip Rack	INTEGRA	1	
24 mm Labware Pedestal	INTEGRA	1	
Thermochromic PCR Cold Block	Parse	2	Pull the Thermochromic PCR Cold Block with riser from the -20°C freezer and leave them at room temperature for 10 minutes prior to use.
Thermochromic PCR Cold Block Riser	Parse	2	
Parse Metal Cold Block	Parse	1	Keep on ice when not in use.
Semi-Skirted 96 Well PCR Plate	Consumables	2	
● Sample Binding Beads	4°C Reagents	1	Keep at room temperature. Ensure beads are not settled before use.
● Sample Dilution Buffer	-20°C Reagents or ECAC3901	1	Thaw at room temperature then store on ice. Mix by inverting 3x.

- Download the Parse Biosciences Evercode WT v4 INTEGRA Sample Loading Table. The most current version of the Evercode WT v4 INTEGRA Sample Loading Table can be found on the Parse Biosciences Customer Support Suite. Customer log-in is required to access the Sample Loading Table.
- Thaw the previously fixed cells/nuclei samples in a water bath set to 37°C until all ice crystals dissolve. Thoroughly mix each sample by pipetting and store on ice.
- If not done beforehand, count the number of cells/nuclei with an automated cell counter or alternative cell counting device. Record the cell/nuclei count. This will be used to fill out the Sample Loading Table in section 1.1.9b.

9. Fill the Sample Loading Table tab of the worksheet.

a. Per the instructions in the worksheet, input number of samples (Figure 1).



Note: For more information on using the Sample Loading Table, see the "Important Guidelines" section of the User Guide.

This sheet should be filled out prior to starting Section 1.

Step	Instructions
1	Ensure Macros are enabled.
2	Input the number of samples.
3	Input the target number of barcoded cells. Note: The default is 100,000 cells for Evercode WT.
4	Input your sample names.
5	Input the target percentage representation of each sample in the final library. CRITICAL: No percentage can be lower than 2.09%. If not already done, count the samples as described in Section 1.1 of the Evercode WT User Manual.
6	Input stock cell concentration for each sample.
7	Prepare the dilutions as described. CRITICAL: Ensure that Sample Dilution Buffer is completely thawed before use.
8	Open the "Plate Configuration" sheet. With the plate on ice, add 14 μ L of each diluted sample to the appropriate well(s) of the Round 1 Plate as shown in the plate map. CRITICAL: Follow the instructions in the User Guide with respect to sample mixing and changing tips.

Number of Samples (Step 2): **CRITICAL:** We do not recommend editing cells highlighted in grey.

Target Number Barcoded Cells (Step 3):

Sample #	Sample Name (Step 4)	Percent of Library (Step 5)	Stock Concentration (cells/ μ L) (Step 6)	Number of Wells	Targeted Number of Barcoded Cells	Required Sample Concentration (cells/ μ L)
1		100.00%		48	100000	520
TOTALS:		100.00%		48	100,000	

Figure 1: Evercode WT Sample Loading Table.

b. Enter Target Number of Barcoded Cells, Sample Name, Percent of Library and Stock Concentration for corresponding samples. Errors and possible solutions can be found in Appendix D (Figure 2).



Note: If any parameter is out of range, the cells will turn pink in color and/or an error message will appear (Figure 2). Be sure to address and adjust worksheet input values appropriately before continuing.

This sheet should be filled out prior to starting Section 1.

Step	Instructions
1	Ensure Macros are enabled.
2	Input the number of samples.
3	Input the target number of barcoded cells. Note: The default is 100,000 cells for Evercode WT.
4	Input your sample names.
5	Input the target percentage representation of each sample in the final library. CRITICAL: No percentage can be lower than 2.09%. If not already done, count the samples as described in Section 1.1 of the Evercode WT User Manual.
6	Input stock cell concentration for each sample.
7	Prepare the dilutions as described. CRITICAL: Ensure that Sample Dilution Buffer is completely thawed before use.
8	Open the "Plate Configuration" sheet. With the plate on ice, add 14 μ L of each diluted sample to the appropriate well(s) of the Round 1 Plate as shown in the plate map. CRITICAL: Follow the instructions in the User Guide with respect to sample mixing and changing tips.

Number of Samples (Step 2): **CRITICAL:** We do not recommend editing cells highlighted in grey.

Target Number Barcoded Cells (Step 3):

Sample #	Sample Name (Step 4)	Percent of Library (Step 5)	Stock Concentration (cells/ μ L) (Step 6)	Number of Wells	Targeted Number of Barcoded Cells	Required Sample Concentration (cells/ μ L)
1	SA-0001	32.00%	500	14	32000	571
2	SA-0002	48.00%	3,300	24	48000	499
3	SA-0003	20.00%	5,250	10	20000	499
TOTALS:		100.00%		48	100,000	

CRITICAL: This cell stock concentration is too low.

Figure 2: Example error message, noting that the sample stock concentration is too low.

- c. Navigate to the "INTEGRA Loading Table" tab. If the "Required Number of Sample Dilution Tubes" is greater than 1, three additional dilution buffer tubes for highly concentrated samples can be purchased as a Sample Dilution Accessory Kit (see "Sample Concentrations" in Important Guidelines) (Figure 3).



Note: Example: Sample 1 is loaded into Sample Location A1 and Sample Location A2 with a minimum volume of 131 μ L. More sample volume (up to a maximum of 200 μ L total sample volume) can be loaded to reduce bubbles during mixing.

Sample Name	Sample Location	Min Sample Stock Needed for Dilution (uL)	Min Diluent Needed (uL)	Required Number of Sample Dilution Tubes	Sample Dilution Tube Locations
Sample 1	A1	131.0	1955.0	2	
Sample 1	A2	131.0			
Sample 2	A3	84.0			
Sample 3	A4	84.0			
Sample 4	A5	84.0			
	A6				
	A7				
	A8				
	A9				
	A10				
	A11				
	A12				
	B1		*EXTRA SAMPLE DILUTION TUBES REQUIRED TO COMPLETE INTEGRA SAMPLE NORMALIZATION*		

Figure 3: INTEGRA Loading Table tab noting Minimum Diluent Needed and Sample Locations.

- d. Referring to the "INTEGRA Loading Table" tab, manually load fixed samples into the directed "Sample Location" well into a new Eppendorf semi-skirted plate. Note that any individual sample may require loading into more than one "Sample Location" well. This is the sample stock plate. Store the sample stock plate on ice for later use.
- e. Navigate to the "Diluent Volumes" tab and click on the purple box labeled "Generate a Worklist for Import into VIALAB". Save the generated CSV file (called "CombinedWTWorksheet_YYYYMMDD_HHMMSS.csv") for later use (Figure 4).

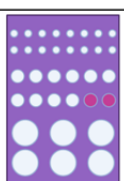
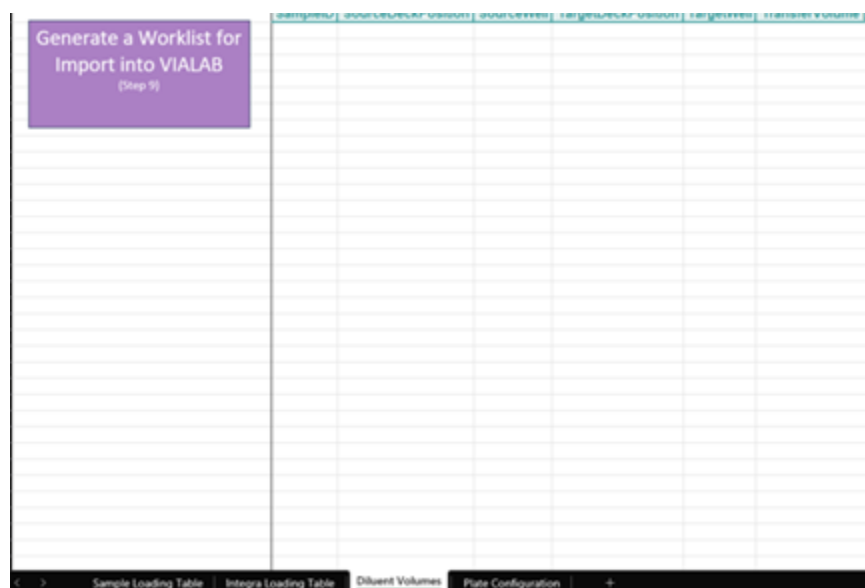

Figure 4: Diluent Buffer Volumes tab for generating a VIALAB worklist.

- f. Navigate to the "Plate Configuration" tab to visualize the final sample location within the 96 well plate format (Figure 5).

Parse Biosciences
700 Dexter Ave
Suite 600
Seattle, WA 98109



Evercode WT Round 1 Barcoding Plate Configuration

- For more details on using this Sample Loading Table, see the Important Guidelines section of the User Manual

Use the following plate layout to load samples into the Round 1 Plate in Section 1.2.

	1	2	3	4	5	6	7	8	9	10	11	12
A	1	1	1	1	1	1	1	1	1	1	1	1
B	1	1	2	2	2	2	2	2	2	2	2	2
C	2	2	2	2	2	2	2	2	2	2	2	2
D	2	2	3	3	3	3	3	3	3	3	3	3
E	Do not add samples to these wells.											
F	Do not add samples to these wells.											
G	Do not add samples to these wells.											
H	Do not add samples to these wells.											

Sample Number	Sample Name	Percent Contributing
1	SA-0001	32.00%
2	SA-0002	48.00%
3	SA-0003	20.00%

Figure 5: Plate Configuration tab visualizes the sample locations.

10. Import the generated CSV files into VIALAB to be uploaded on the pipettes.

- a. Open the VIALAB program **WT S1 St1 DONE V4_0** and navigate to the "Method" section.



CRITICAL! Delete any previous S1 St1 scripts from the D-ONE pipette to avoid running incorrect scripts.

- b. In the "02 Worklist", under the "Worklist and Volumes" tab, upload the "CombinedWTWorksheet_YYYYMMDD_HHMMSS.csv" worklist file generated in Step 9e using the "Import" button (Figure 6).

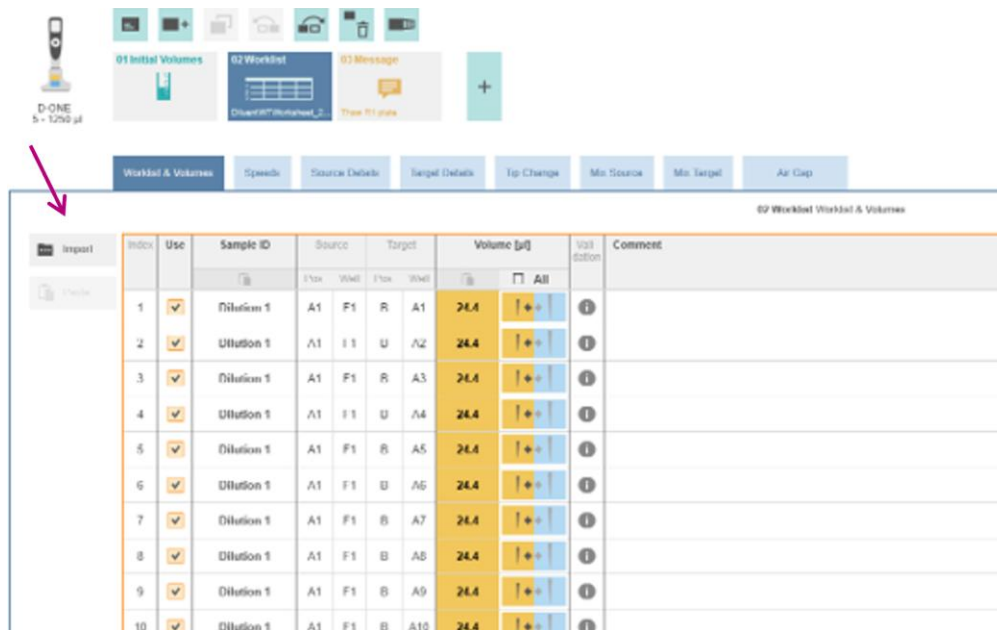
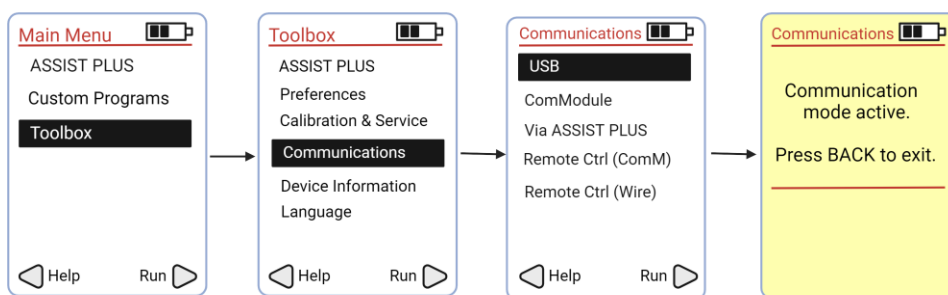

Figure 6: VIALAB worklist generation for diluent volumes using O2 Worklist.

11. Save and transfer your program to your D-ONE Pipetting Module (1-Ch, 5-1250 µL) as follows, ensuring that any program previously uploaded on the pipette is deleted:

- a. Connect your computer with D-ONE Pipette using Communication/Charging Cable for VIAFLO.
- b. Follow the instructions on the pipette menu, as shown in the diagram below:



- c. Select the "Transfer" tab in the opened **WT S1 St1 DONE V4_0** VIALAB program.
- d. Confirm that the pipette has been recognized by the software. Click "Send to pipette". An audible signal will indicate the successful upload of the WT S1 St1 V4 program to the D-ONE Pipette.
- e. Disconnect the cable and proceed with the protocol on the INTEGRA ASSIST PLUS platform.

- f. If done correctly, a program named **WT S1 St1 V4_0** will be found on your pipette as shown in the diagram below.

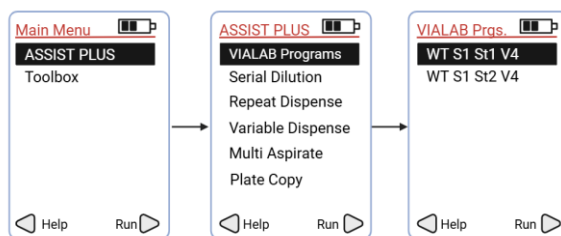

12. Load the hardware on deck.

- a. Load the Parse Cold Block on the 24mm Pedestal on Deck A.
- b. If not done earlier, leave two Thermochromic PCR Cold Blocks with Risers on Deck with A1 at the bottom left corner at room temperature for 10 minutes prior to use. Load one on Deck B and the other on Deck C. The deck should correspond to the Deck Configuration below.



Note: Leave the fully frozen Thermochromic PCR Cold Block with Riser at room temperature for 10 minutes to ensure it is slightly warmed by a few degrees before using it on the INTEGRA ASSIST PLUS Deck.

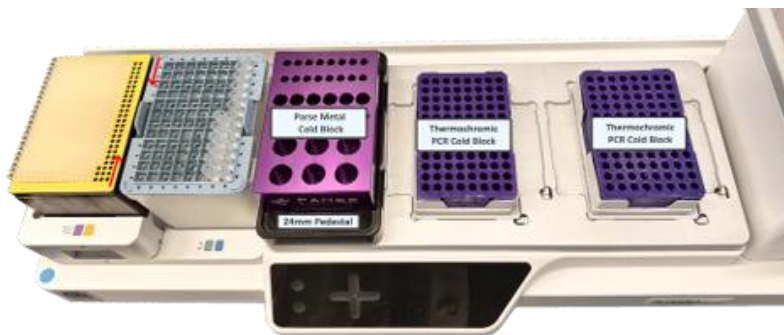

13. Load the following reagents and consumables to their respective positions on Decks A, B and C:

- a. Deck A, column 2
 - i. Pos 7: ● Sample Dilution Buffer.



Note: If the Sample Loading table states that more than 1 Sample Dilution Buffer tube is required, follow the INTEGRA Loading Table tab Sample Dilution Table Locations image for tube loading (Figure 3).

- b. Deck B: a clean semi-skirted plate on Deck B with A1 corner in the bottom left.
- c. Deck C: Sample plate with A1 corner in the bottom left.
 - i. Label the 96-well plate that contains your Parse-fixed samples as the **Sample Plate**.
 - ii. Refer to the Integra Loading Table tab of the Sample Loading Table for correct sample layout in the **Sample Plate**.
 - iii. If samples have been frozen in individual 1.5 mL Protein LoBind Tubes or 8-strip PCR tubes, they will need to be transferred to a LoBind 96-well plate on the day of Barcoding.

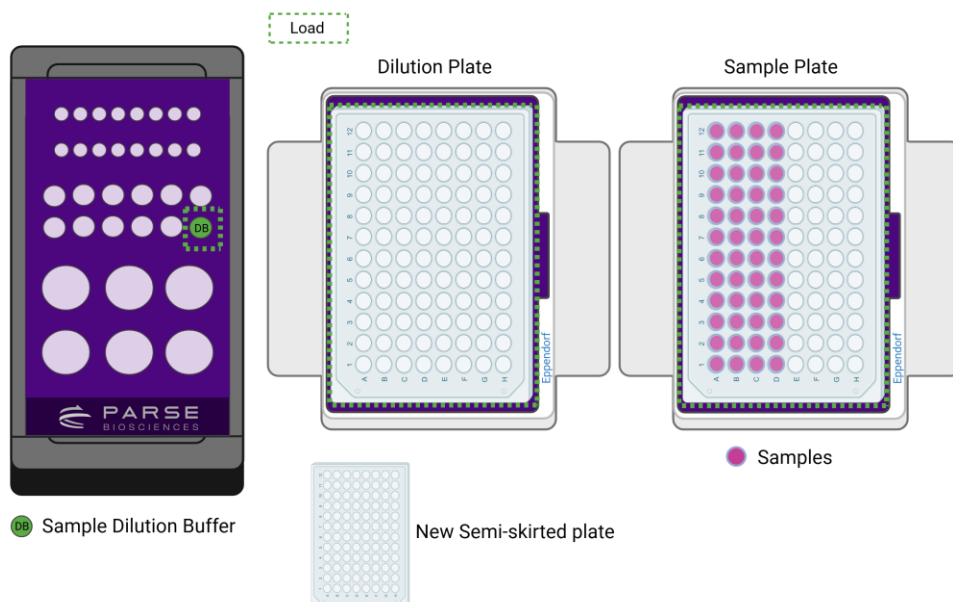

14. Attach D-ONE Pipetting Module 1-Ch, 5-1250 μ L and the corresponding Tip Deck. Ensure the Tip Deck and tip box are securely positioned by pressing them down firmly until they click into place. Remove the tip box lid prior to starting the program.

- a. Remove the reagent caps, then select and run the program **WT S1 St1 V4_0**.

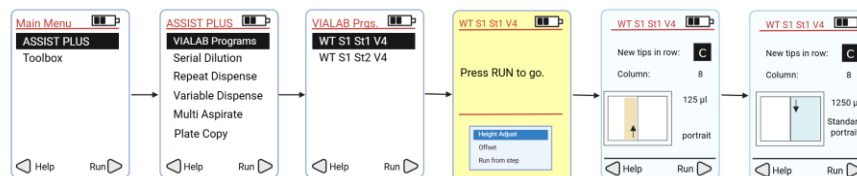

15. At the conclusion of the run:

- a. Store any remaining ● Sample Dilution Buffer from Deck A on ice. Keep the hardware on Deck A. This will be used in the next step.
- b. Label the plate on Deck B as the **Dilution Plate** and store on ice. This will be used in WT S1 St3. Remove the Thermochromic PCR Cold Block from Deck.
- c. Remove all labware on Deck C. Discard the used **Sample Plate** on Deck C.

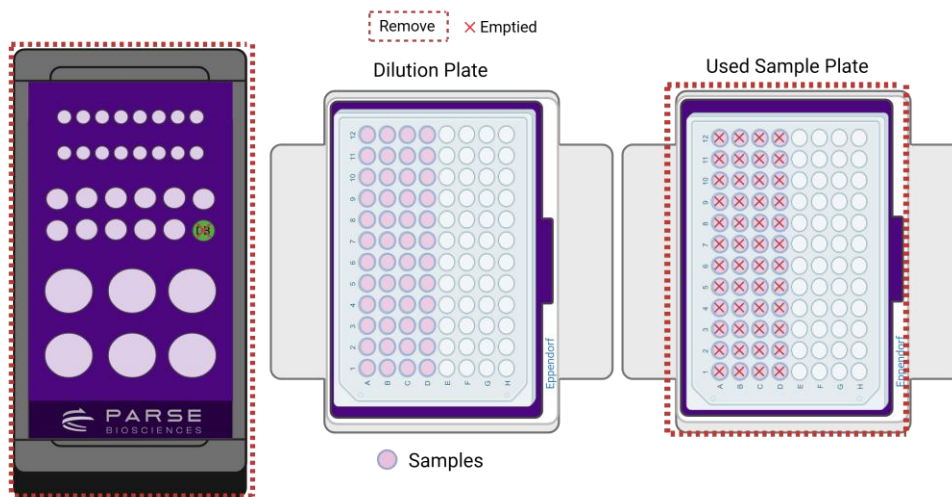

1.2. Reagents Preparation

This program takes reagents from Deck A and moves them into 8 Row Reservoir positions in Decks B and C. The Lysis Master Mix will be made and aliquoted into an 8-count PCR strip tube. This master mix is stored at room temperature until required.

To prepare the reagents:

1. Gather the following components and reagents:

ITEM	SOURCE	QTY	HANDLING AND STORAGE
Tip Deck for D-ONE Pipetting Module	INTEGRA Component	1	
Tip Deck for D-ONE Pipetting Module 1-Ch, 5-1250 μ L	INTEGRA Component	1	
125 μ L Tip Rack	INTEGRA	1	
1250 μ L Tip Rack	INTEGRA	1	
24 mm Labware Pedestal	INTEGRA	1	
Parse Metal Cold Block	Parse	1	Keep on ice when not in use.
Cooling Adapter Base	Parse	1	If previously frozen, leave at room temperature for 10 minutes prior to use. If not previously frozen, fill with pebble ice prior to use. Replace ice as necessary.
Self-Standing 8 Row Reservoir Adapter	Parse	1	
HEATMAG Module	INTEGRA Component	1	
Heatmag 8 Row Reservoir Adapter	Parse	1	
Heatmag Cooling Accessory	Parse	1	If previously frozen, leave at room temperature for 10 minutes prior to use. If not previously frozen, fill with pebble ice prior to use. Replace ice as necessary.

ITEM	SOURCE	QTY	HANDLING AND STORAGE
6-Tube Magnetic Separation Rack	Equipment	1	
8-count PCR strip tube	Consumables	1	
1.5 mL tube	Consumables	1	
Self-Standing 8 Row Reservoir	Consumables	2	
● Round 2 Stop Mix	-20°C Reagents	1	Thaw at room temperature then store on ice. Mix by vortexing. Briefly centrifuge before use.
○ Final Stop Mix	-20°C Reagents	1	Thaw at room temperature then store on ice. Mix by vortexing. Briefly centrifuge before use.
○ Pre-Lysis Wash Buffer	-20°C Reagents	1	Thaw at room temperature then store on ice. Mix by vortexing.
● Round 1 Stop Mix	-20°C Reagents	1	Thaw at room temperature then store on ice. Mix by inverting 3x.
○ Ligation Buffer	-20°C Reagents	1	
● Bead Prep Buffer	-20°C Reagents	1	
○ Barcoding Buffer	-20°C Reagents	1	Thaw in 37°C water bath, then store on ice.
● Ligation Enzyme	-20°C Reagents	1	Place directly on ice. Briefly centrifuge before use.
● Lysis Enzyme	-20°C Reagents	1	
● Lysis Solution	-20°C Reagents	1	Thaw and store at room temperature.

2. Fill a Cooling Adapter Base with pebble ice and place it on Deck B. If the Cooling Adapter Base was filled with water and frozen the night before, ensure that the Cooling Adapter Base is thawed at room temperature for at least **10 minutes** before use.
3. Place the Self-Standing 8 Row Reservoir Cooling Adapter on the Cooling Adapter Base on Deck B.
4. Place the HEATMAG with the INTEGRA logo oriented to the left on Deck C. Ensure the wires are not interfering with the HEATMAG position. Ensure HEATMAG power is on for the duration of Section 1.

5. Fill the HEATMAG Cooling Accessory with pebble ice. If the HEATMAG Cooling Accessory was filled with water and frozen the night before, ensure that the HEATMAG Cooling Accessory is thawed at room temperature for at least **10 minutes** before use.
6. If not done already, remove the PCR plate adapter from the HEATMAG. Place the HEATMAG 8 Row Reservoir Adapter and HEATMAG Cooling Accessory on the HEATMAG following the figure below.

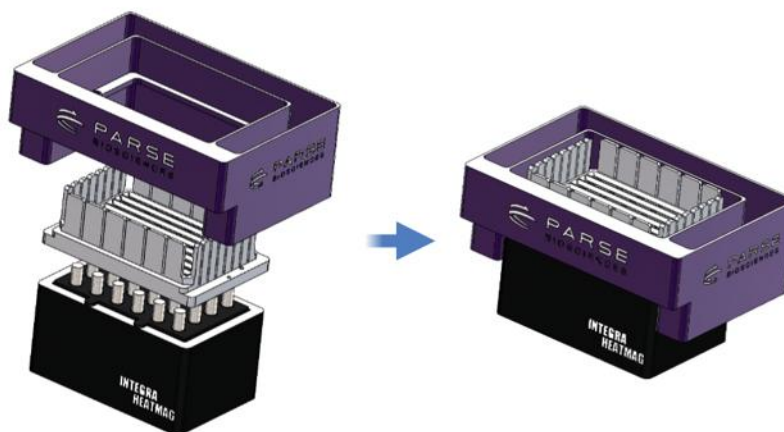
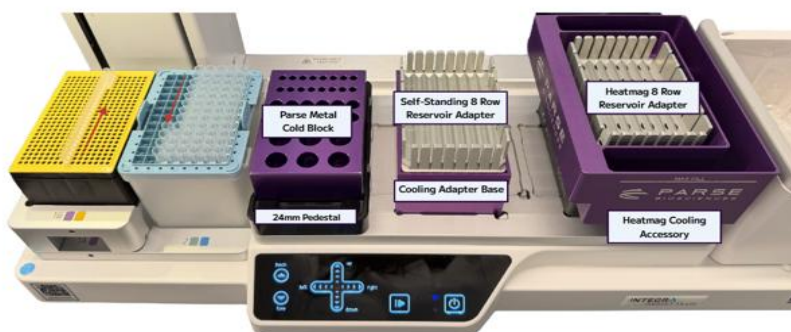

Figure 7: Graphic depicting how the HEATMAG 8 Row Reservoir Adapter and HEATMAG Cooling Accessory fit on the INTEGRA HEATMAG. To check proper alignment, the magnet can be set to high.

7. The deck should match the configuration below.



8. Load the consumables, reagents, and samples on Deck:
 - a. Load a clean Self-Standing 8 Row Reservoir on Deck B on the Self-Standing 8 Row Reservoir Cooling Adapter with Row A oriented to the left. Label this reservoir as **Reservoir 1**.

- b. Load a clean Self-Standing 8 Row Reservoir on Deck C on the HEATMAG 8 Row Reservoir Adapter with Row A oriented to the left. Label this reservoir as **Reservoir 2**.
- c. Load the reagents and consumables on the Parse Metal Cold Block on Deck A. If necessary, briefly spin down the tubes to ensure the liquid is at the bottom of the tubes.
 - i. Column 1:
 - a. Left: Clean 8-count PCR strip tube.
 - ii. Column 2:
 - i. Pos 1: ● Round 1 Stop Mix
 - ii. Pos 2: ● Round 2 Stop Mix
 - iii. Pos 3: ● Ligation Enzyme
 - d. Pos 4: Clean 1.5 mL tube
 - v. Pos 5: ● Lysis Enzyme
 - vi. Pos 6: ● Lysis Solution
 - iii. Column 3:
 - i. Pos 1: ○ Final Stop Mix
 - ii. Pos 2: ○ Pre-Lysis Wash Buffer
- d. Load a clean Self Standing 8 Row Reservoir on Deck B on the Self-Standing 8 Row Reservoir Cooling Adapter with Row A oriented to the left. Label this reservoir as **Reservoir 1**.
- e. Load a clean Self Standing 8 Row Reservoir on Deck C on the HEATMAG 8 Row Reservoir Adapter with Row A oriented to the left. Label this reservoir as **Reservoir 2**.

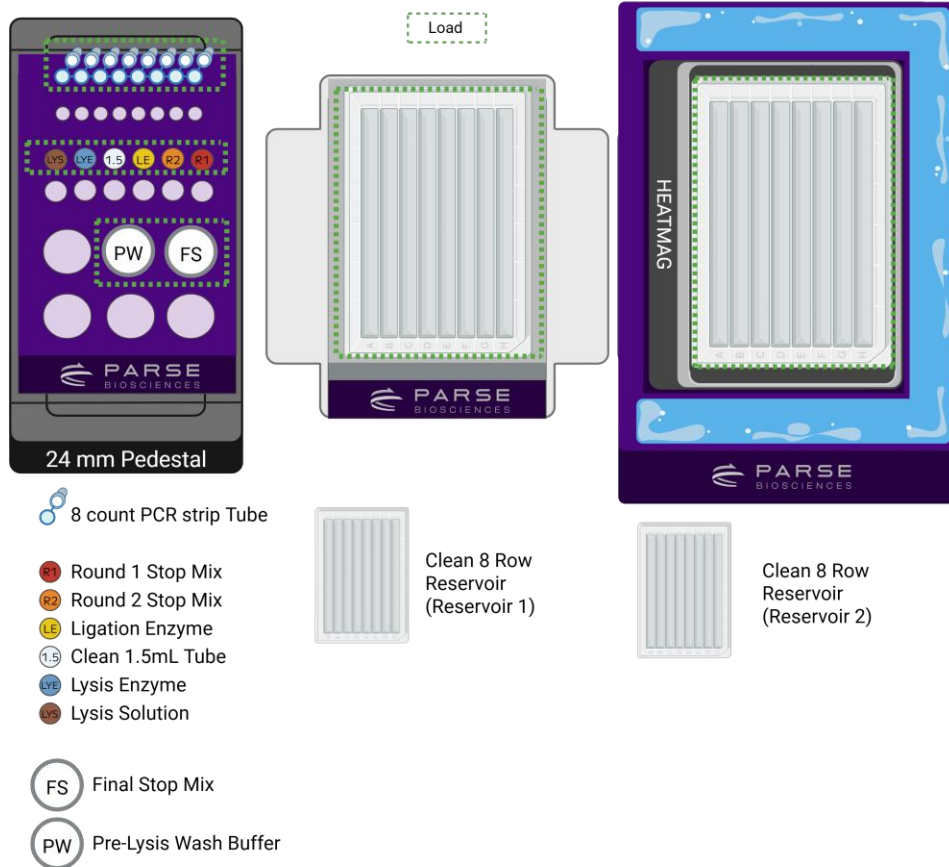

9. Remove the reagent caps, select and run the program **WT S1 St2 V4_0** following the diagram below.



10. Press “Run” to continue the program. Follow the program prompts for manual intervention:

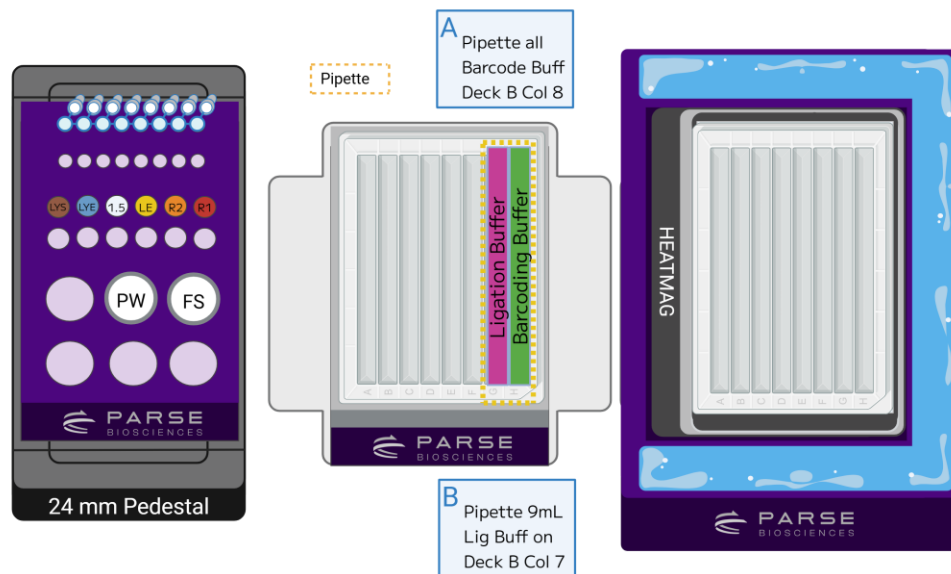

- a. Pipette entire volume of Barcoding Buffer (~13 mL) into Row H of **Reservoir 1** using a clean 10 mL serological pipette.
 - b. Pipette **9 mL** of ○ Ligation Buffer into Row G of **Reservoir 1** using a clean 10 mL serological pipette.
11. While the program is running, manually wash and prep the ● Sample Binding Beads. **If using low input fixation samples, cells/nuclei have been already captured. Skip this step and do not generate the Cell Capture Master Mix.**
- a. Gently pulse-vortex ● Sample Binding Beads to resuspend and store at room temperature. Do not let them settle for >3 minutes before pipetting. Transfer **200 µL** of ● Sample Binding Beads to a 1.5 mL tube.
 - b. Place the tube on the magnetic rack compatible with 1.5 mL tubes and wait for the solution to clear (~2 minutes).
 - c. While still on the magnet, remove and discard the supernatant.
 - d. Remove the tube from the magnetic rack and fully resuspend the bead pellet in **200 µL** of ● Bead Prep Buffer.
 - e. Place the tube on the magnetic rack until the solution clears (~2 minutes).
 - f. While still on the magnet, remove and discard the supernatant.

- g. Repeat steps 11d - 11f two more times for a total of 3 washes.
- h. Remove the tube from the magnetic rack. Fully resuspend the pellet in **200 µL** of ○ Barcoding Buffer and store on ice. Barcoding Buffer is in Row H of **Reservoir 1**. Label this tube **CCMM** (Cell Capture Master Mix) and store it on ice for later use.

12. At the conclusion of the run:

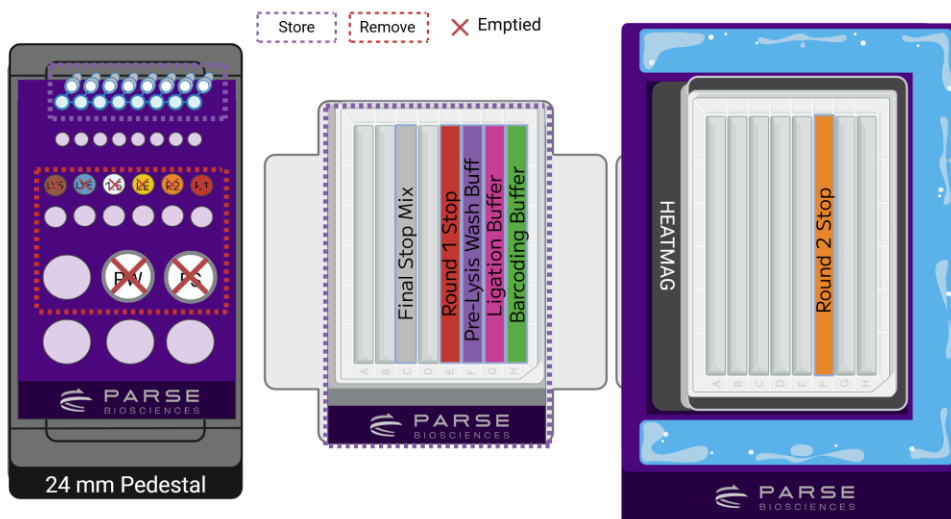

- a. Close the lids and store the 8-count PCR strip tube from the Parse Cold Block Column 1 Left position at room temperature. This contains the Lysis Master Mix and will be used at the end of Section 1. Label this **Lysis Master Mix**.
- b. Discard all used 1.5 mL, 2 mL, and 5 mL tubes from Deck A. Remove all of the labware on Deck A.
- c. Remove all labware from Deck B. Seal **Reservoir 1** with a PCR plate seal. Store the Cooling Adapter Base, Self-Standing 8 Row Reservoir Cooling Adapter and **Reservoir 1** on ice.

1.3. Round 1, Round 2, Round 3 Plate Loading and Pooling

This program loads samples into the Round 1 Plate on Deck A from the Dilution Plate on Deck B. A deck change occurs where Reservoir 1 is loaded on Deck B. The Round 1 Plate is pooled into Reservoir 1 and the HEATMAG module is used to prepare the sample for Round 2 loading. The Round 2 Plate is then loaded using the prepared sample. The process repeats for Round 2 Pooling and Round 3. At the end of the program, samples will be ready for counting and lysate creation.

1. Gather the following components and reagents:

ITEM	SOURCE	QTY	HANDLING AND STORAGE
VIAFLO Pipette 12-Ch 5-300 μ L	INTEGRA Components	1	
Tip Deck for VIAFLO Pipetting Module	INTEGRA Components	1	
300 μ L Tip Rack	INTEGRA	3	
Thermochromic PCR Cold Block	Parse	2	Pull the Thermochromic PCR Cold Block with riser from the -20°C freezer and leave them at room temperature for 10 minutes prior to use.
Thermochromic PCR Cold Block Riser	Parse	2	
Cooling Adapter Base	Parse	1	Replace ice as necessary.
Self-Standing 8 Row Reservoir Adapter	Parse	1	
HEATMAG Module	INTEGRA Components	1	
Heatmag 8 Row Reservoir Adapter	Parse	1	
Heatmag Cooling Accessory	Parse	1	Replace ice as necessary.
Plate Seals	Consumables	as needed	
 Round 1 Plate	-20°C Reagents	1	Place directly on ice.
 Round 2 Plate V4	-20°C Reagents	1	
 Round 3 Plate	-20°C Reagents	1	

2. Thaw the Round 1 Plate using the following thermocycling program. Remove two Thermochromic PCR Cold Blocks to thaw at room temperature for 10 minutes during the following thermocycling program.

THAW ROUND 1 PLATE		
Run Time	3 minutes	
Lid Temperature	70°C	
Sample Volume	26 µL	
Step	Time	Temperature
1	3 min	25°C
2	Hold	4°C

3. At the completion of the thermocycler program, centrifuge the Round 1 Plate for **1 minute** at 100 x g at 4°C.
4. Load two Thermochromic PCR Cold Blocks with Risers on Deck with A1 on the bottom left. Place one on Deck A and the other on Deck B. The deck should correspond to the Deck Configuration below.



Note: Leave the fully frozen Thermochromic PCR Cold Block with Riser at room temperature for **10 minutes** to ensure it is slightly warmed by a few degrees before using it on the INTEGRA ASSIST PLUS Deck.

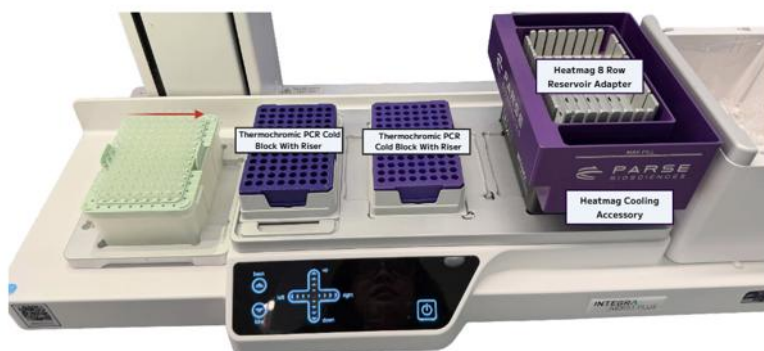

5. Load the reagents and samples on deck:
 - a. Deck A: While secured in a PCR plate rack on a flat surface, remove the plate seal from the Round 1 Plate and place it on Deck A with A1 at the bottom left.
 - b. Deck B: **Dilution Plate** stored from step 1.1.15b. with A1 corner in the bottom left. **If using Low Input Fixed Samples, the captured and diluted samples can be**

loaded instead of the **Dilution Plate** from step 1.1.15b. Make sure the layout of the samples in the **Dilution Plate** match the Plate Configuration tab of your Sample Loading Table.

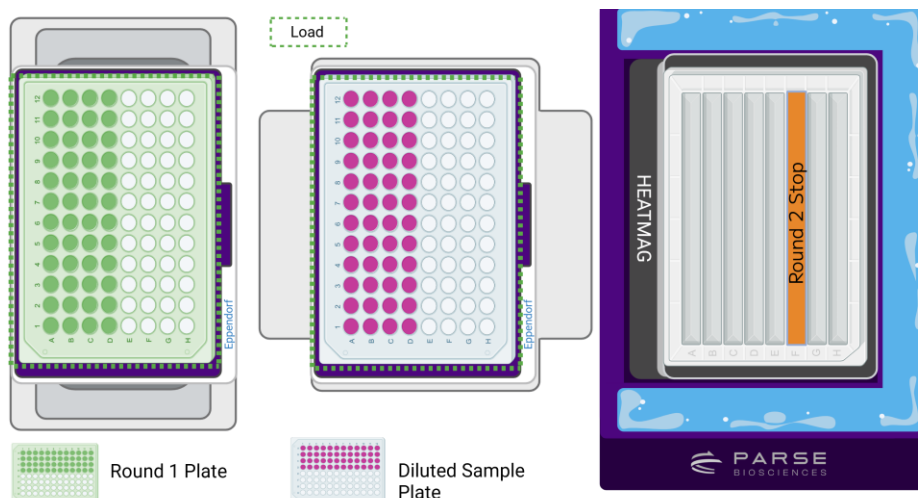

6. Change the pipette that is connected to the INTEGRA ASSIST PLUS:
 - a. Remove D-ONE Pipetting Module 1-Ch, 5-1250 μ L and corresponding Tip Decks. Ensure it is disconnected by pressing the back button until the main menu is displayed.
 - b. Replace it with VIAFLO 12-Ch 10-300 μ L Pipette and corresponding Tip Deck. Ensure the Tip Deck and tip box are securely positioned by pressing them down firmly until they click into place. Remove the tip box lid prior to starting the program.
7. Run the program **WT S1 St3 V4_0** following the diagram below.

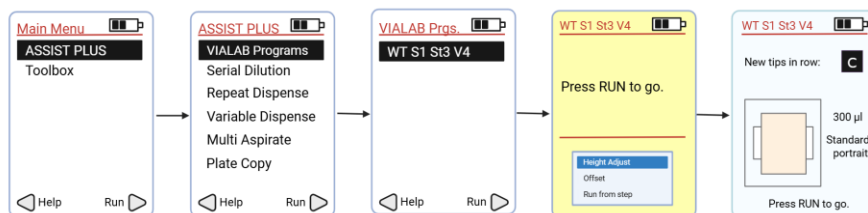

8. Press "Run" to continue the program. Follow the program prompts for manual intervention.

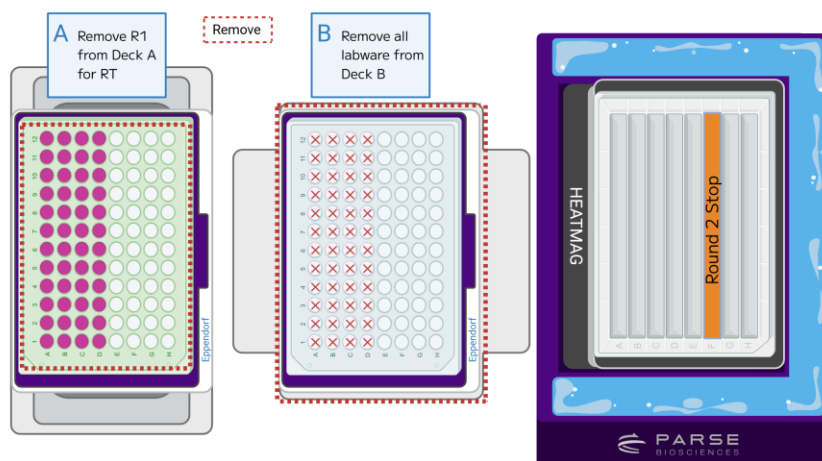

- a. When prompted, remove and seal the Round 1 Plate from Deck A using the Plate Seal Applicator. Place the Round 1 Plate into a thermocycler and run the following program. With the thermal cycler running, press "Run" on the pipette to proceed. Follow the program prompts for manual intervention.

BARCODING ROUND 1			
Total Run Time		40 minutes	
Lid Temperature		70°C	
Sample Volume		40 µL	
Step	Time	Temperature	Cycles
1	10 min	50°C	1
2	12 sec	8°C	3
3	45 sec	15°C	
4	45 sec	20°C	
5	30 sec	30°C	
6	2 min	42°C	
7	3 min	50°C	1
8	5 min	50°C	
9	Hold	4°C	1



CRITICAL! In section 1.4, you will need a thawed Thermochromic PCR Cold Block with a Thermochromic PCR Cold Block Riser. We recommend either leaving one block at

room temperature for the remainder of the section 1.3 process, or running it under warm water to thaw quickly prior to section 1.4.

9. While the thermocycling program is running, remove all labware from Deck B. The used **Dilution Plate** can be discarded. Remove the Thermochromic PCR Cold Block located on Deck B and store it in the freezer upside down for future use.

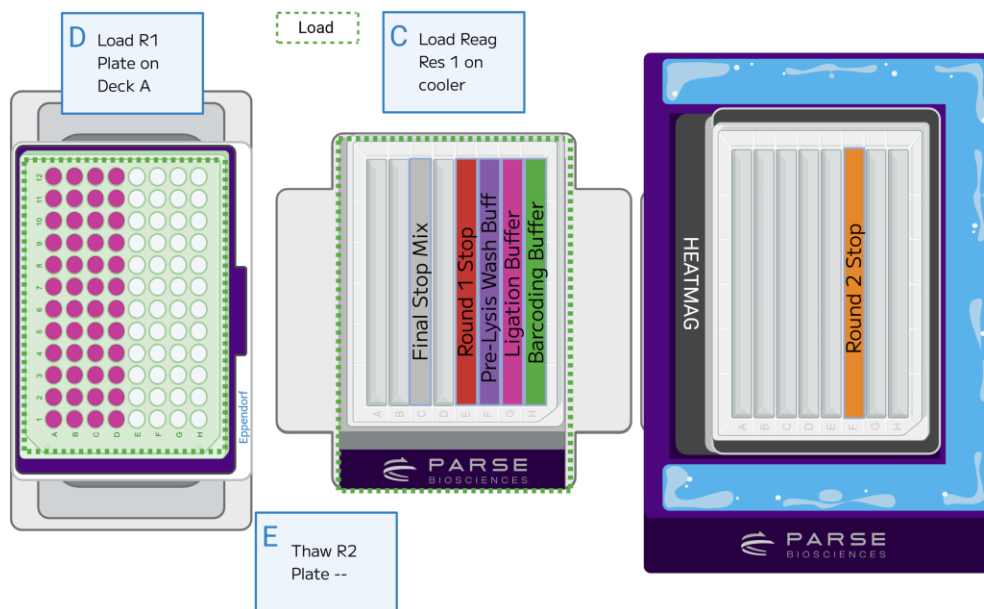
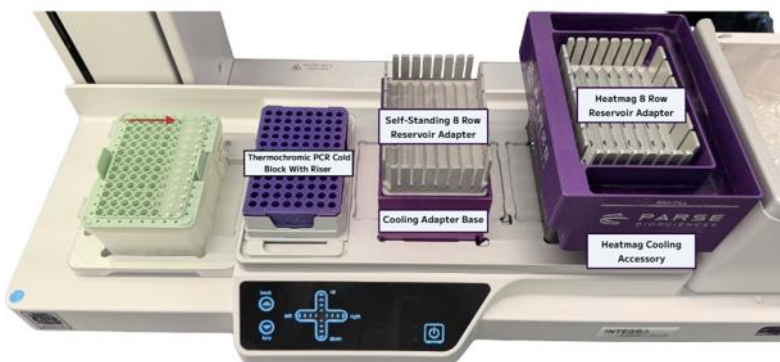

10. Load **Reservoir 1** with the Self-Standing 8 Row Reservoir Cooling Adapter on the Cooling Adapter Base stored from step 1.2.12c on Deck B. Ensure row A is facing the left side.
11. When the Barcoding Round 1 Thermocycling program is complete, load the Round 1 Plate on the Thermochromic PCR Cold Block on Deck A with A1 on the bottom left.

12. Gather the following:

ITEM	SOURCE	QTY	HANDLING AND STORAGE
Thermochromic PCR Cold Block	Parse	1	Pull the Thermochromic PCR Cold Block with riser from the -20°C freezer and leave them at room temperature for 10 minutes prior to use.
Thermochromic PCR Cold Block riser	Parse	1	
Round 2 Plate v4	-20°C Reagents	1	Place directly on ice.

13. Thaw the Round 2 Plate using the program below for later use. While the program is still running, remove a frozen Thermochromic PCR Cold Block with Riser from -20°C freezer and thaw at room temperature for later use.

THAW ROUND 2 PLATE		
Run Time	3 minutes	
Lid Temperature	70°C	
Sample Volume	10 µL	
Step	Time	Temperature
1	3 min	25°C
2	Hold	4°C

14. At the completion of the thermocycling program, centrifuge the Round 2 Plate for **1 minute** at 100 x g at 4°C. Place the Round 2 Plate on ice for later use

15. While the thermocycling program is running, remove the plate seals from **Reservoir 1** and the Round 1 Plate. Press "Run" to continue the program. Follow the program prompts for manual intervention.

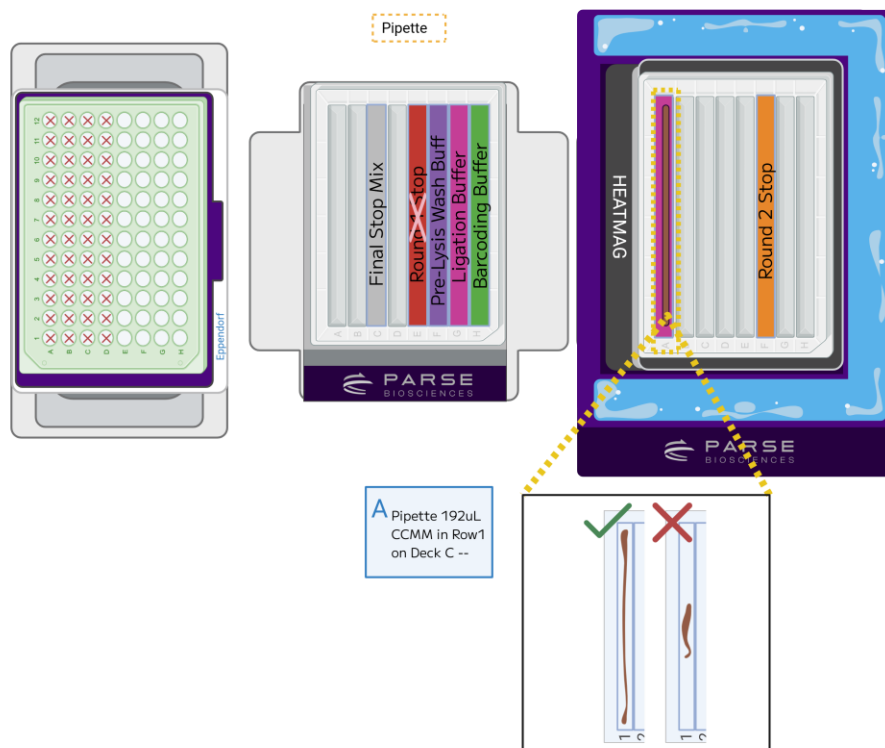

- If using low input fixation samples, cells/nuclei have been already captured. **Skip this step and do not add Cell Capture Master Mix to the reservoir.** If using standard fixation samples, resuspend any settled beads in the Cell Capture Master Mix (CCMM) from step 1.2.11h by pipette mixing. Pipette **192 μ L** of the CCMM across Row A of **Reservoir 2** on Deck C.
- Pipette across the whole row to ensure even cell capture. Tilt the reservoir and mix the CCMM with the sample 20 times with a P1000 pipette set to 1000 μ L.
- Return reservoir to flat position and spread out beads evenly across Row A to ensure even capture.

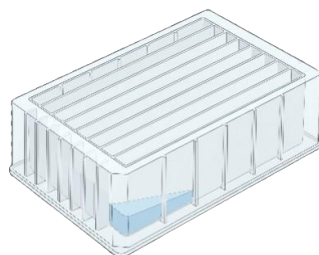

16. Press “Run” to continue the program. Follow the program prompts for manual intervention.

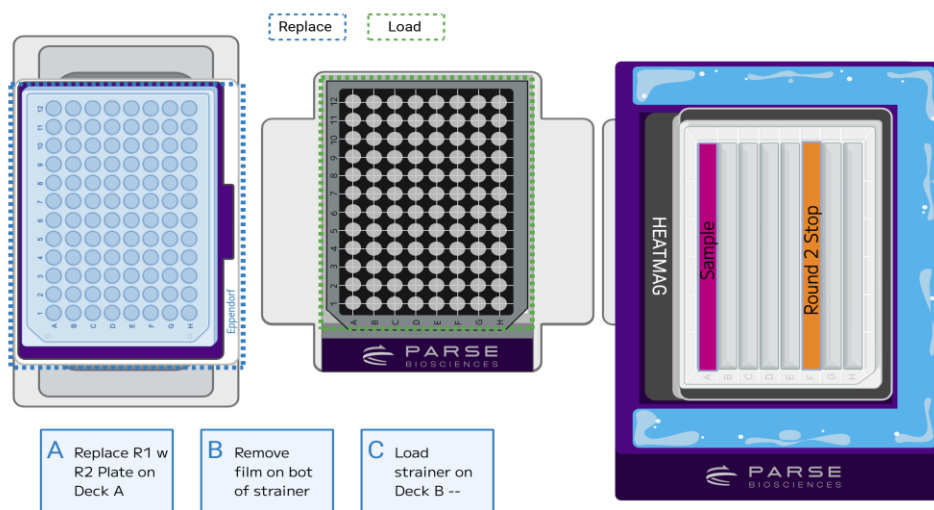

- Replace the Round 1 Plate and Thermochromic PCR Cold Block with Riser on Deck A with the Round 2 Plate and Thermochromic PCR Cold Block with Riser thawed in step 1.3.13.
- Open a new Rigid Plate Strainer. Remove the film on the bottom of the strainer.



CRITICAL! Choose an appropriate mesh size for your sample type. The wrong size will lead to cell loss.

- Load the Rigid Plate Strainer and press firmly on top of **Reservoir 1** on Deck B. Ensure A1 is on the bottom left.

17. Press “Run” to continue the program. Follow the program prompts for manual intervention.

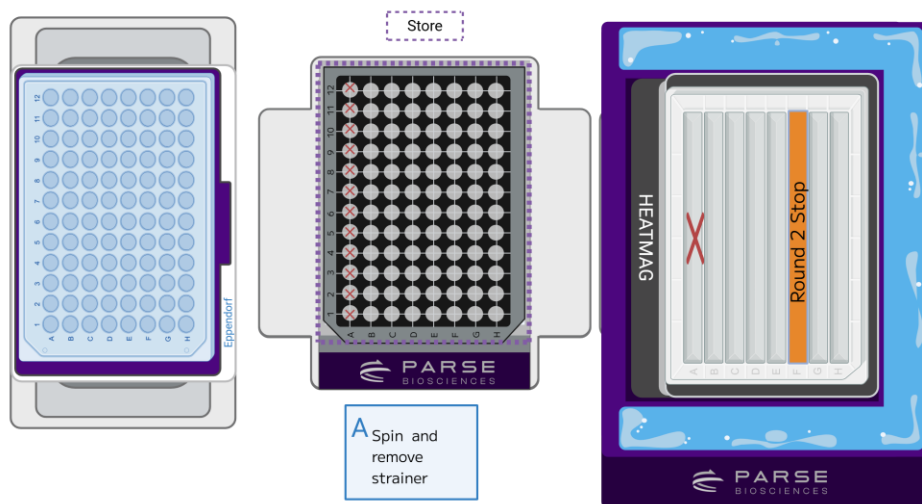

- a. Ensuring the strainer is not jostled, carefully remove **Reservoir 1** with the strainer on top from deck B. Centrifuge the strainer on **Reservoir 1** at 100g x **10 seconds**. Remove and store the strainer on a clean semi-skirted plate for later use. Reload the **Reservoir 1** on Deck B.

18. Press “Run” to continue the program. Follow the program prompts for manual intervention.

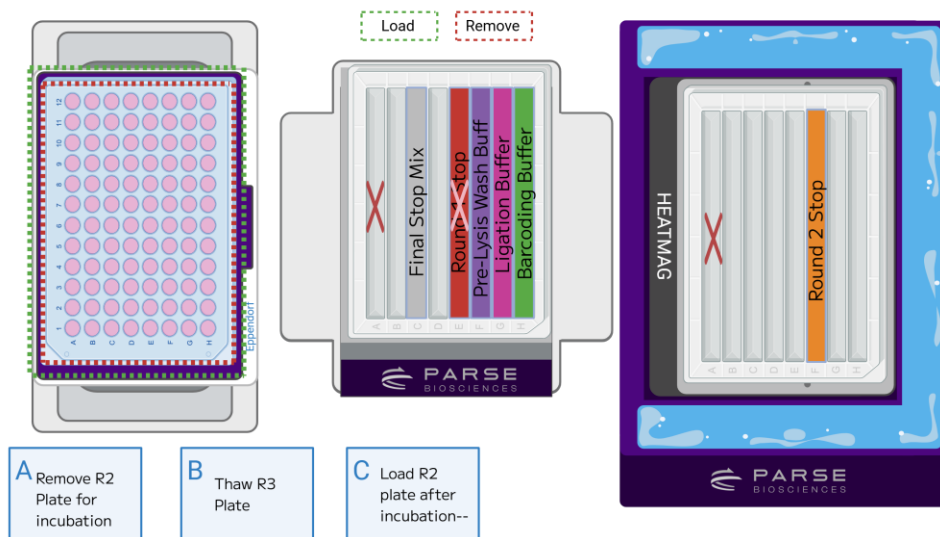

19. Remove and seal the Round 2 Plate from Deck A using the Plate Seal Applicator. Place the Round 2 Plate into a thermocycler and run the following program

BARCODING ROUND 2		
Run Time	15 minutes	
Lid Temperature	50°C	
Sample Volume	50 µL	
Step	Time	Temperature
1	15 min	16°C
2	Hold	4°C

20. Gather the following:

ITEM	SOURCE	QTY	HANDLING AND STORAGE
Thermochromic PCR Cold Block	Parse	1	Pull the Thermochromic PCR Cold Block with riser from the -20°C freezer and leave them at room temperature for 10 minutes prior to use.
Thermochromic PCR Cold Block riser	Parse	1	
Round 3 Plate	-20°C Reagents	1	Place directly on ice.
6-Tube Magnetic Separation Rack	Equipment	1	
● Pre-Lysis Dilution Buffer	-20°C Reagents	1	Thaw at room temperature then store on ice. Mix by inverting 3x.

21. At the completion of the Barcoding Round 2 thermocycling program, thaw the Round 3 Plate using the program below for later use. While the Thaw Round 3 Plate program is still running, remove a frozen Thermochromic PCR Cold Block with Riser from -20°C freezer and thaw at room temperature for later use. Press “Run” to continue the pipette program.

THAW ROUND 3 PLATE		
Run Time	3 minutes	
Lid Temperature	70°C	
Sample Volume	10 µL	
Step	Time	Temperature
1	3 min	25°C
2	Hold	4°C

22. At the completion of the thermocycling program, centrifuge the Round 3 Plate for **1 minute** at 100 x g at 4°C. Place the Round 3 Plate on ice for later use.

23. Load the Round 2 Plate on the Thermochromic PCR Cold Block on Deck A and remove the seal. Ensure A1 is on the bottom left. Press “Run” to continue the program.

24. Follow the program prompts for manual intervention.

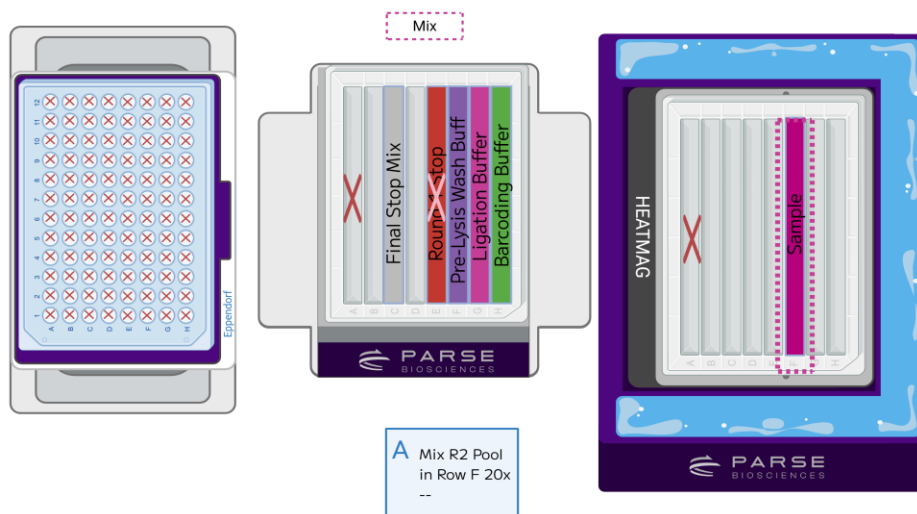

- a. Tilt **Reservoir 2** on Deck C and mix the sample pool in Row F 20 times with a P1000 pipette set to 1000 μ L. Place back on Deck C and ensure the sample is evenly spread across the row.
25. Press "Run" to continue the program. Follow the program prompts for manual intervention.

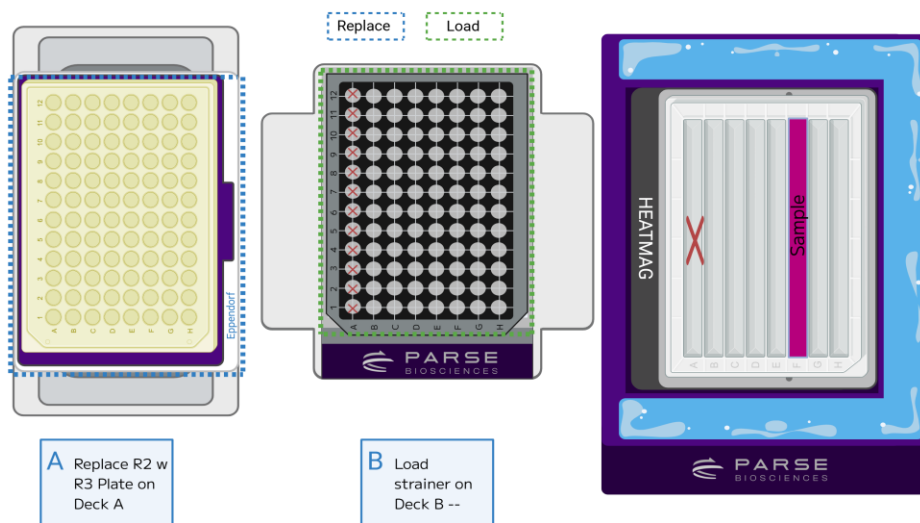

- a. Replace the Round 2 Plate and Thermochromic PCR Cold Block with Riser on Deck A with the Round 3 Plate and Thermochromic PCR Cold Block with Riser thawed in step 1.3.21.
- b. Load the Rigid Plate Strainer stored from step 1.3.17a on top of **Reservoir 1** on Deck B. Ensure A1 is on the bottom left. Press firmly to ensure proper loading.
26. Press "Run" to continue the program. Follow the program prompts for manual intervention.

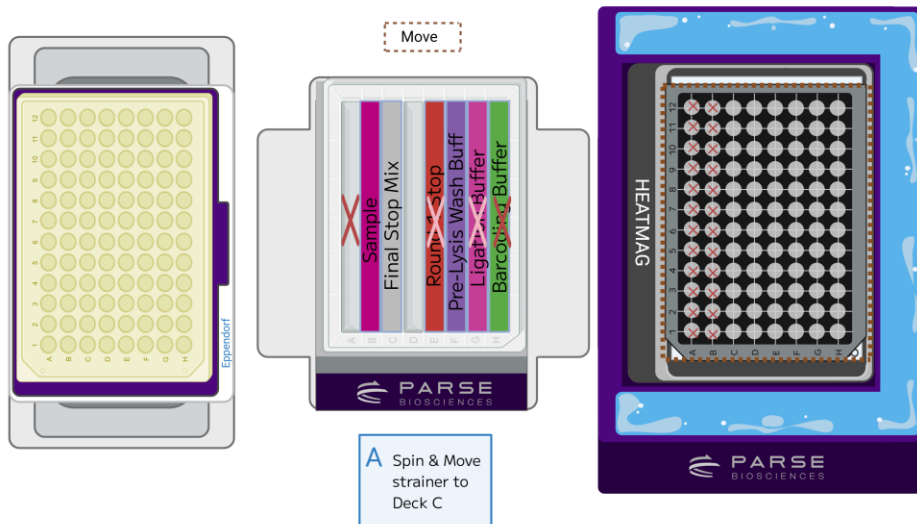

- a. Ensuring the strainer is not jostled, carefully remove **Reservoir 1** with the strainer on top from deck B. Centrifuge the strainer on **Reservoir 1** at 100g x **10 seconds**. Move the strainer to **Reservoir 2** on Deck C. Reload the **Reservoir 1** on Deck B.

27. Press "Run" to continue the program. Follow the program prompts for manual intervention.

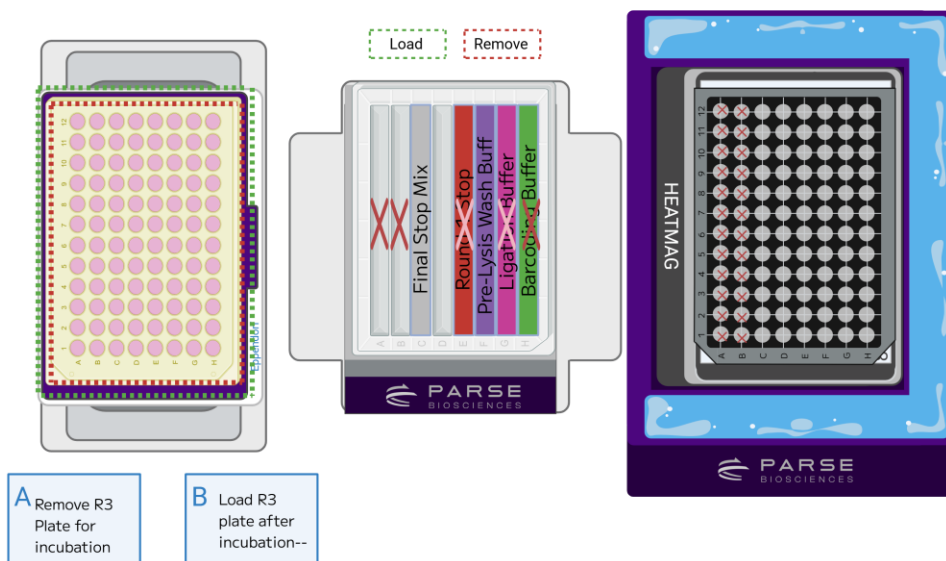

- a. Remove and seal the Round 3 Plate from Deck A using the Plate Seal Applicator. Place the Round 3 Plate into a thermocycler and run the following program.

BARCODING ROUND 3		
Run Time	15 minutes	
Lid Temperature	50°C	
Sample Volume	50 µL	
Step	Time	Temperature
1	15 min	16°C
2	Hold	4°C

- b. When the Round 3 Thermocycling program is complete, load the Round 3 Plate on the Thermochromic PCR Cold Block on Deck A and remove the seal. Ensure A1 is on the bottom left. Press "Run" to continue the program.

28. Follow the program prompts for manual intervention.

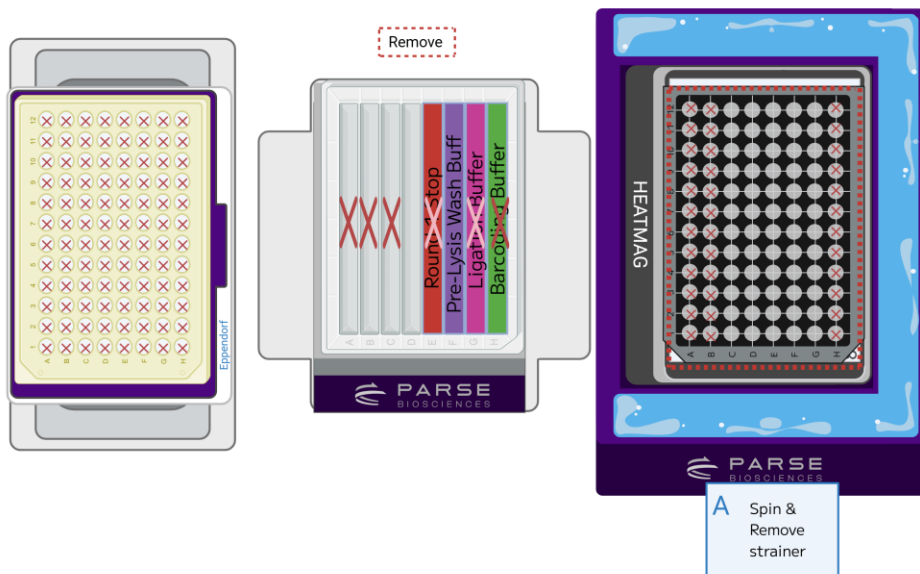

- a. Ensuring the strainer is not jostled, carefully remove **Reservoir 2** with the strainer on top from deck C. Centrifuge the strainer on **Reservoir 2** at 100g x **10 seconds**. Reload the **Reservoir 2** on Deck C. The strainer will no longer be used for this section and can be discarded.

29. Press “Run” to continue the program. Follow the program prompts for manual intervention.

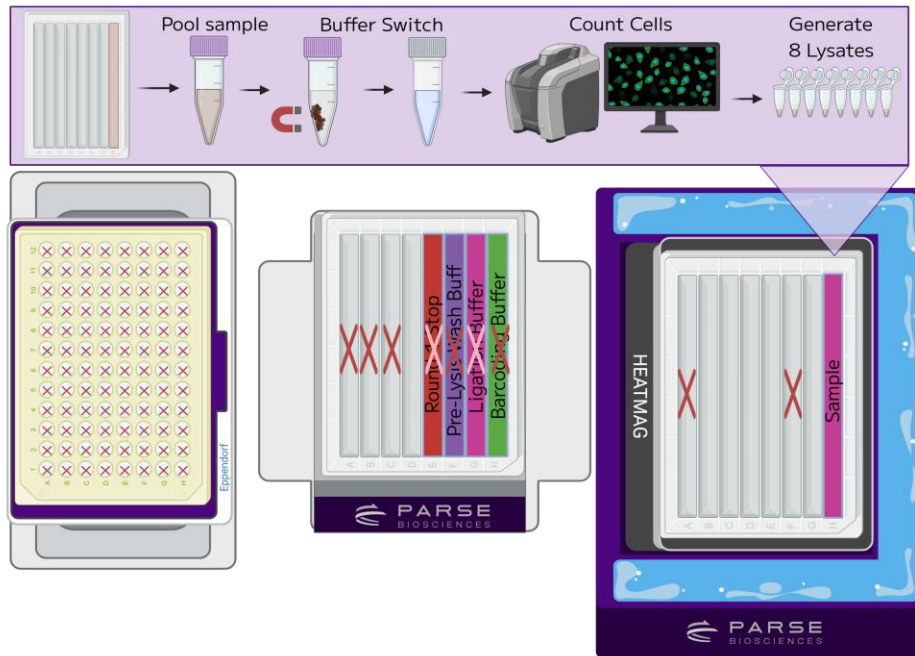

- Immediately after the last supernatant removal, manually pool all of the beads from Row H of **Reservoir 2** on Deck C into a clean 1.5 mL tube using a P200 set to 200 μ L. If the remaining volume is less than 200 μ L in the 8 Row Reservoir, add 200 μ L of volume from Row D of **Reservoir 2**.
- Place the 1.5 mL tube on a magnet on ice and cover the tube in ice up to the liquid level. Allow beads to bind to the magnet (~2 minutes), remove and discard the supernatant, then fully resuspend the pellet in **80 μ L** of ● Pre-Lysis Dilution Buffer. Keep this tube on ice. **It contains your cells bound to the beads.**
- Count the number of cells/nuclei in the sample with a fluorescent (DAPI or equivalent) cell counting device. Record the cell/nuclei count.
- Decide how to divide cells/nuclei across the 8 sublibraries. See the “Sublibrary Loading” in the Important Guidelines section for strategies. Use the Sublibrary Generation Table in Appendix A to determine the volume of sample and ● Pre-Lysis Dilution Buffer that should be added to each sublibrary.



CRITICAL! Do not add more than 12,500 cells/nuclei to a sublibrary. Adding additional cells/nuclei will result in an increased multiplet rate.

- e. Ensure the cells/nuclei are in suspension by pipetting 5x with a P200 set to 50 μ L immediately before each transfer. Add the appropriate volume of sample to 8 different 0.2 mL PCR tubes.
- f. Keeping the samples on ice, add the appropriate volume of ● Pre-Lysis Dilution Buffer to the 0.2 mL tubes for a total volume of 25 μ L in each tube.

30. At the conclusion of the run:

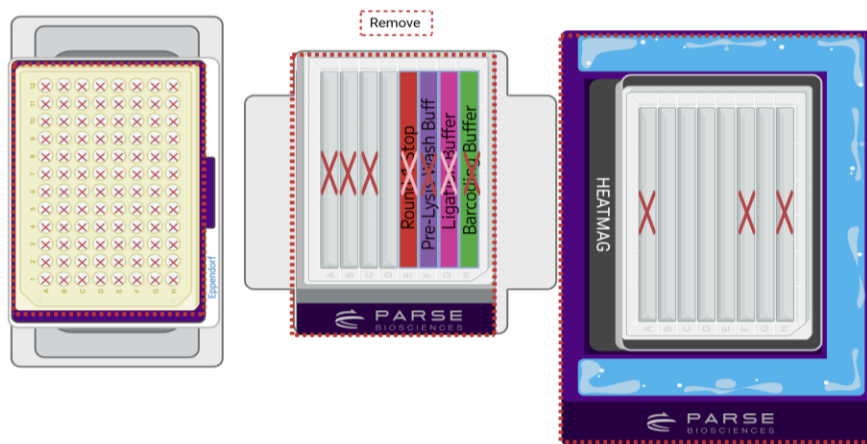

- a. Remove all labware from Deck B. **Reservoir 1** can be discarded. Remove the Self-Standing 8 Row Reservoir Cooling Adapter and the Cooling Adapter Base.
- b. Discard the used Round 3 Plate on Deck A. Move the thawed ThermoChromic PCR Cold Block with ThermoChromic PCR Cold Block Riser from Deck A to Deck B with A1 to the top left following the diagram below.
- c. Remove all the adapters on the HEATMAG. **Reservoir 2** can be discarded. Remove the HEATMAG 8 Row Reservoir Adapter and HEATMAG Cooling Accessory. Rotate the INTEGRA HEATMAG so the power button faces the front of the INTEGRA ASSIST PLUS base unit.

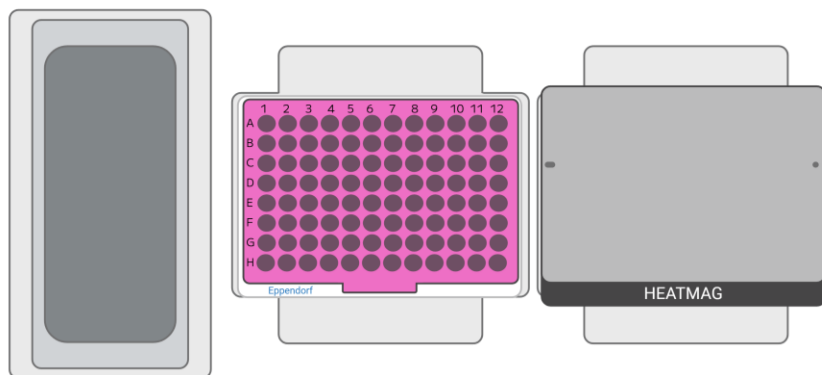

1.4. Lysate Creation

The program requires 8 sublibrary aliquots in one 8-count PCR strip tube. The program will add lysis master mix to the aliquots. After the lysis thermocycling program, the robot will remove the cell binding beads and store the 8 libraries in the first column of a semi-skirted 96 well plate.

1. Gather the following items and handle as indicated below:

ITEM	SOURCE	QTY	HANDLING AND STORAGE
VOYAGER Pipette 8-Ch 5-125 μ L	INTEGRA Components	1	
Tip Deck for VOYAGER Pipetting Module	INTEGRA Components	1	
125 μ L Tip Rack	INTEGRA	1	
SealPlate®	Consumables	1	
Plastic plate sealer	Consumables	1	
TempPlate Sealing® Foil	Consumables	1	
HEATMAG with 96 Well Adapter	INTEGRA	1	
Semi-Skirted 96 Well PCR Plate	Consumables	1	
Thermochromic PCR Cold Block	Parse	1	Allow the Cold Block to reach room temperature.
Thermochromic PCR Cold Block Riser	Parse	1	

2. Place the 96 well HEATMAG adapter on the INTEGRA HEATMAG Module.
3. The deck should match the configuration below.



4. Load the consumables, reagents, and samples on Deck:

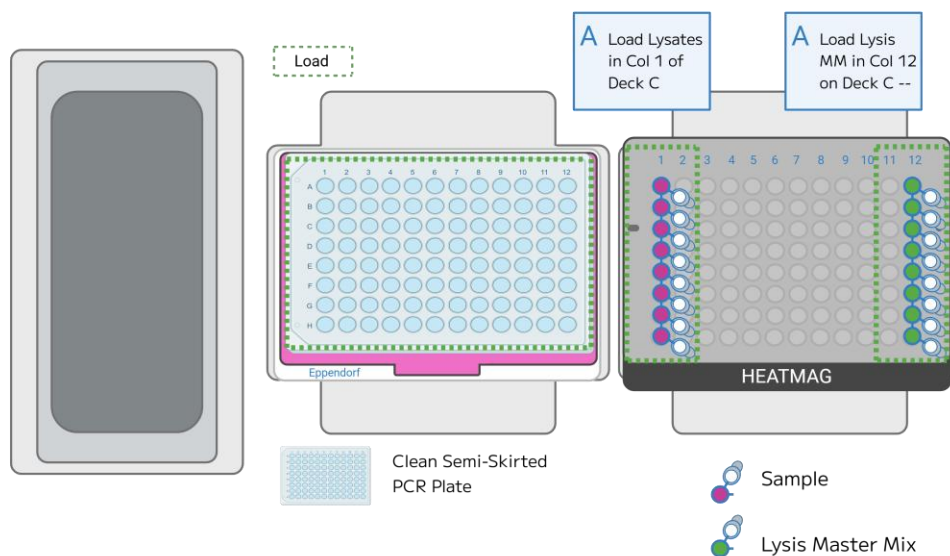

- a. Deck B: A clean Eppendorf semi-skirted 96 well PCR Plate with A1 in the upper left corner, pressing firmly to ensure the plate is fully seated.
- b. Deck C:
 - a. Col 1: 8-count PCR strip tubes containing the sample lysates made in Step 1.3.29f. Ensure the PCR strip tube caps are facing the same direction. Push the caps wide open to avoid interference with the pipette's tips.
 - b. Col 12: 8-count PCR strip tubes containing the Lysis Master Mix stored in Step 1.2.12a.

5. Change the pipette that is connected to the INTEGRA ASSIST PLUS:

- a. Remove VIAFLO 12-Ch 10-300 μ L and corresponding Tip Deck. Ensure it is disconnected by pressing the back button until the main menu is displayed.
- b. Replace it with VOYAGER 8-Ch 5-125 μ L Pipette and corresponding Tip Deck. Ensure the Tip Deck and tip box are securely positioned by pressing them down firmly until they click into place. Remove the tip box lid prior to starting the program.

6. Select and run the program **WT S1 St4 V4_0** following the diagram below.

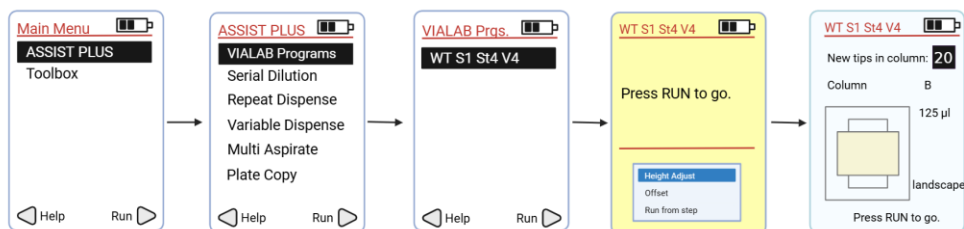

7. Press “Run” to continue the program. Follow the program prompts for manual intervention.

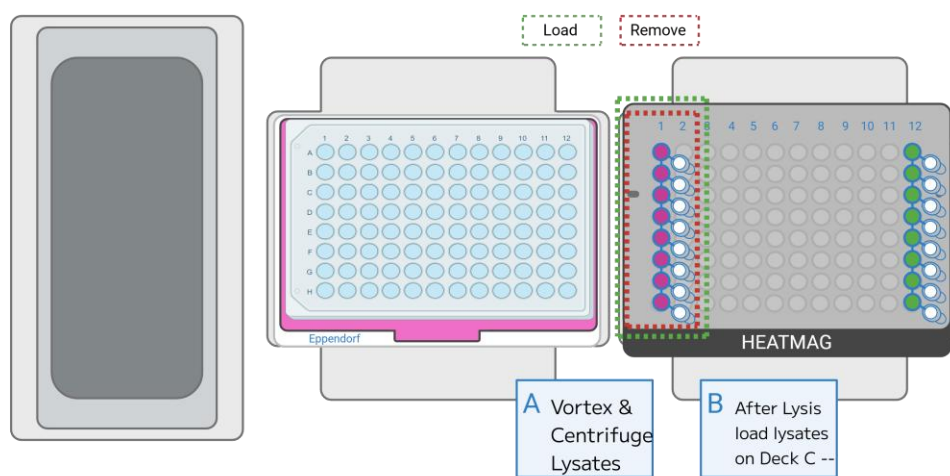

- a. Remove the samples from Column 1 of Deck C. Close the lids and vortex the 0.2 mL tube(s) for **1 minute**. Briefly centrifuge. Place the tube(s) into a thermocycler and run the following program.

CELL/NUCLEI LYSIS		
Run Time	15 minutes	
Lid Temperature	80°C	
Sample Volume	55 µL	
Step	Time	Temperature
1	15 min	65°C
2	Hold	4°C

- a. When the Cell/Nuclei Lysis program is complete, load the 8-count PCR sample tubes in Column 1 of the HEATMAG with 96 Well Adapter. Ensure the 8-count PCR strip tube caps are open and facing the same direction. Push the PCR strip tube caps wide open to avoid interference with the pipette's tips. Press "Run" to continue the program.
8. At the conclusion of the run:
- a. Column 1 of the semi-skirted plate on Deck B contains the lysates. Label this plate as your **Lysate Plate**. Seal the plate with a foil plate seal, then add a plastic plate seal on top of the foil plate seal. Freeze the lysates at -80°C . Alternatively, proceed directly to Section 2.



CRITICAL! Many clear plastic seals are not designed for storage at -80°C , so we recommend using foil plate seals for storing samples in PCR plates.

- b. The used 8-count PCR sample tubes on Deck C can be discarded.

Safe stopping point: Sublibrary lysates in the **Lysate Plate** can be stored at -80°C for up to 6 months.



Section 2: cDNA Capture and Amplification

2.1. Reagents Plating

SPRI beads, Streptavidin Beads, Bead Wash and Binding Buffer are dispensed into a **Reagent Plate**. The Wash A and Wash B Buffers are dispensed into the INTEGRA 8 Row Reservoir on Deck A.

1. If continuing directly from Section 1, store lysates on ice until prompted.
2. Fill an ice bucket.
3. Gather the following items and handle as indicated below.

ITEM	SOURCE	QTY	HANDLING AND STORAGE
D-ONE Pipetting Module 1-Ch, 5-1250 µL	INTEGRA Component	1	
Tip Deck for D-ONE Pipetting Module	INTEGRA Component	1	
125 µL Tip Rack	INTEGRA	1	
1250 µL Tip Rack	INTEGRA	1	
24 mm Labware Pedestal	INTEGRA Component	1	
Parse Metal Cold Block	Parse	1	Keep at room temperature.
HEATMAG with 96 Well Adapter	INTEGRA Component	1	
8 Row Reservoir Insert	INTEGRA	1	Individually wrapped consumable
300 mL Reservoir Base	INTEGRA	1	
96 well Semi-Skirted Plate	Consumables	1	
● Streptavidin Beads	4°C Reagents	1	Keep at room temperature.
● Binding Buffer	-20°C Reagents	1	Thaw at room temperature then store on ice. Mix by inverting 3x.
○ Bead Wash Buffer	-20°C Reagents	1	
○ Wash Buffer A	-20°C Reagents	1	
○ Wash Buffer B	-20°C Reagents	1	

4. Place the 24 mm Labware Pedestal on Deck A.
5. Place the Parse Metal Cold Block on Deck B.
6. Place the HEATMAG with 96 Well PCR Adapter (INTEGRA logo oriented to the front) on Deck C. Ensure HEATMAG power is on for the entire duration of Section 2.

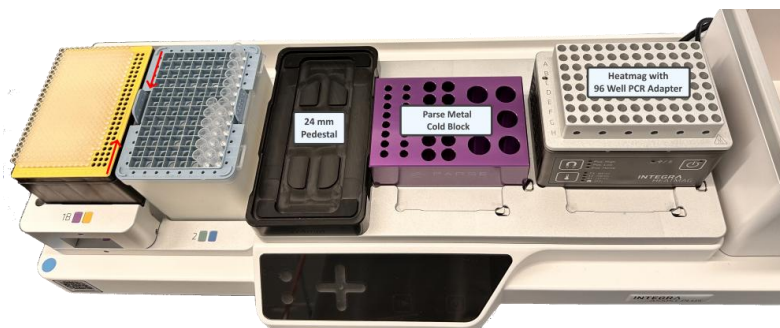

7. Attach D-ONE Pipetting Module 1-Ch, 5-1250 μ L and the corresponding tip rack. Ensure the Tip Deck and tip boxes are securely positioned by pressing them down firmly until they click into place. Remove the tip box lids prior to starting the program.
8. On the 24 mm Pedestal, place a clean INTEGRA 8 Row Reservoir Insert with the 300 mL Reservoir Base with column 1 on the left.
9. Vortex the ● Streptavidin Beads.



Note: Ensure that the Streptavidin Beads are thoroughly mixed before placing them on the deck. Beads can settle if the program isn't started immediately after loading all reagents.

10. Invert Binding Buffer and wash buffers tubes 5 times and briefly centrifuge.
11. Load the following reagents and consumables to their respective positions on the Decks A, B and C:
 - a. Deck A: clean 8 Row Reservoir Insert in a 300mL Reservoir Base.
 - b. Deck B, column 2:
 1. Pos 5: Fully resuspended ● Streptavidin Beads.
 2. Pos 6: ● Binding Buffer.
 - c. Deck B, column 3:
 1. Pos 1: ○ Bead Wash Buffer.

2. Pos 2: ○ Wash Buffer A.
 3. Pos 3: ○ Wash Buffer B.
- d. Deck C: Place a clean Eppendorf 96-well semi-skirted plate on the HEATMAG and label it as the **Reagent Plate**.

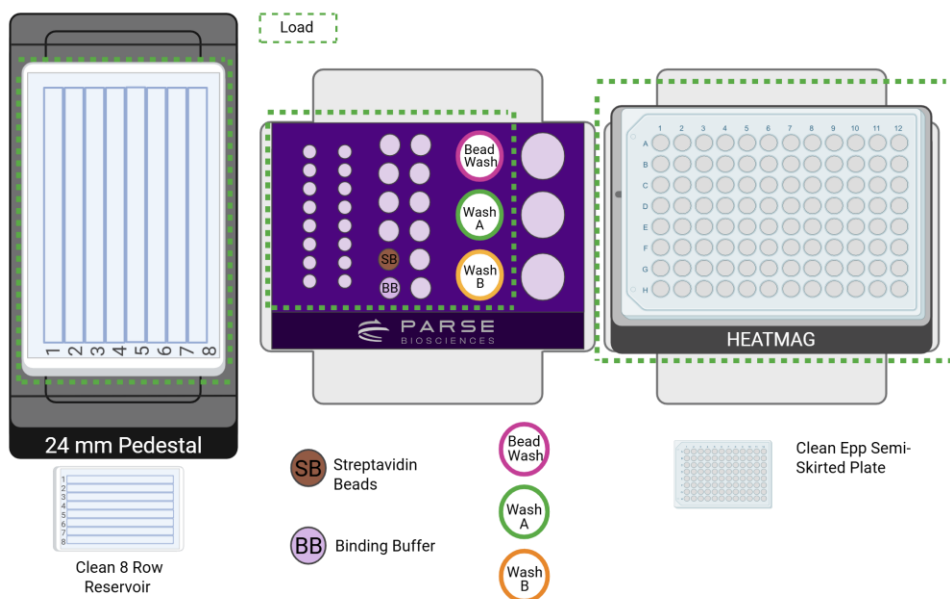

12. Remove all reagent tube caps.

13. On the D-ONE Pipette select and run the program **WT S2 St1 V4_0** following the diagram below.



14. At the conclusion of the run:

- a. Confirm that the Streptavidin Beads are evenly distributed across all wells in column 1 of the **Reagent Plate** on Deck C.
- b. Verify that the Binding Buffer is evenly distributed across all wells in column 3 of the **Reagent Plate** on Deck C.

- c. Verify even Bead Wash Buffer distribution within column 9 . Column 9 may have different target volumes, but all wells within each column should be equal.
- d. Confirm that the full volume of Wash Buffer A has been transferred to column 2 of the 8-row reservoir.
- e. Confirm that the full volume of Wash Buffer B has been transferred to column 3 of the 8-row reservoir.
- f. Remove the Parse Metal Cold Block from Deck B.
- g. Discard the empty tubes and proceed immediately to Section 2.2.

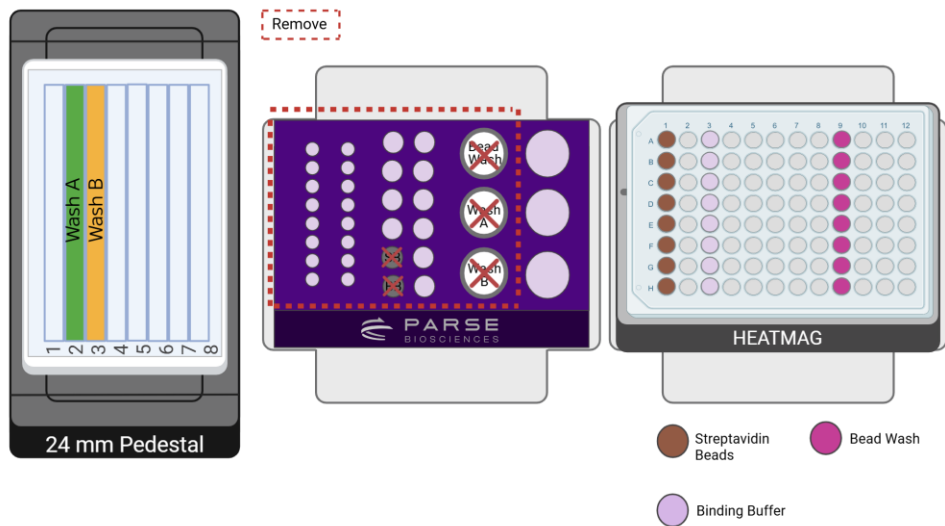

2.2. cDNA Capture

Streptavidin Beads are washed, then cDNA is captured with streptavidin-coated magnetic beads. The program controls the temperature and strength of the HEATMAG with 96 Well Adapter on Deck C.

To capture the cDNA:

1. Gather the following items and set up the deck as shown.

ITEM	SOURCE	QTY	HANDLING AND STORAGE
VOYAGER Pipetting Module 8-Ch 5-125 µL	INTEGRA Component	1	
Tip Deck for VOYAGER Pipetting Module	INTEGRA Component	1	
125 µL Tip Rack	INTEGRA	1	
Thermochromic PCR Cold Block	Parse	1	Ensure the Thermochromic PCR Cold Block with riser is at room temperature before use.
Thermochromic PCR Cold Block Riser	Parse	1	
Vortex Plate Adapter	Equipment	1	
SealPlate®	Consumables	As needed	
TempPlate Sealing® Foil	Consumables	As needed	

2. Set up the deck following the Deck Configuration below.



3. Load the following:
 - a. Place the room temperature Thermochromic PCR Cold Block with Riser on Deck B with A1 on the top left.
4. If continuing from the previous steps, the following should already be loaded:
 - a. Deck A: 8 Row Reservoir with 300 mL Reservoir Base on the 24 mm Riser
 - i. 8 Row Reservoir with Wash Buffer A and Wash Buffer B in columns 2 and 3.
 - b. Deck C: Place the **Reagent Plate** on the HEATMAG with A1 on the upper left corner.
5. Change the pipette that is connected to the INTEGRA ASSIST PLUS:
 - a. Remove D-ONE Pipetting Module 1-Ch, 5-1250 μ L and corresponding Tip Deck. Ensure it is disconnected by pressing the back button until the main menu is displayed.
 - b. Replace it with VOYAGER 8-Ch 5-125 μ L Pipette and corresponding Tip Deck. Ensure the Tip Deck and Tip Box are securely positioned by pressing them down firmly until they click into place. Remove the tip box lid prior to starting the program.
6. Select and run the program **S2 St2 V4_0** following the diagram below.

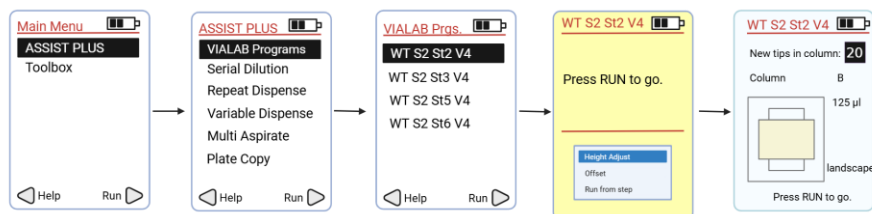

7. Follow the program prompts for manual intervention:

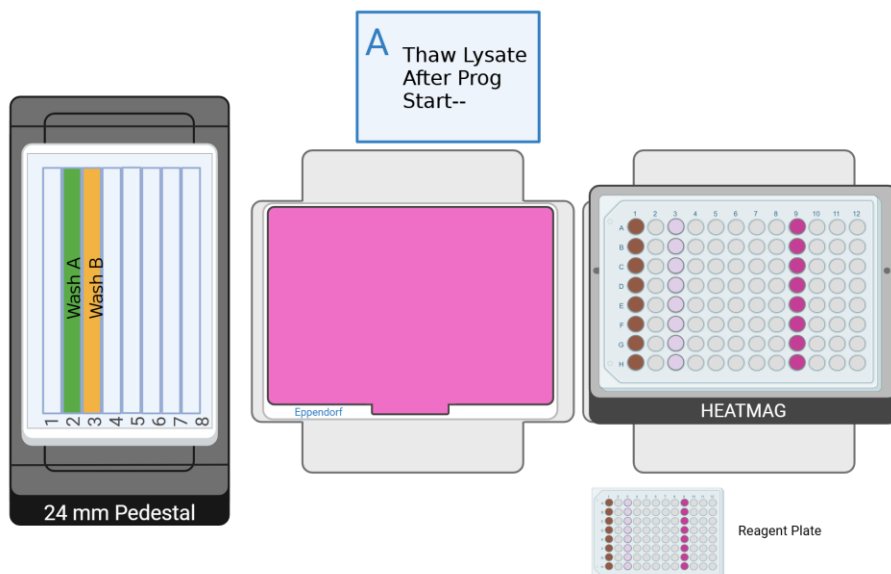

- a. If lysates are previously frozen, when prompted, incubate the lysates in a thermocycler at 37°C for **5 minutes** to thaw them. Press “Run” on the pipette to continue the program while the lysates are thawing.

THAW LYSATE		
Run Time	5 minutes	
Lid Temperature	40°C	
Sample Volume	55 µL	
Step	Time	Temperature
1	5 min	37°C
2	Hold	4°C

8. Label the lysate plate as **Lysate Plate** if it has not been labeled already.
9. When the lysates finish thawing, briefly centrifuge **1 minute** at 100 x g at 4°C and store on ice.



Note: When thawing the lysate, ensure there is no precipitate before proceeding. Otherwise, an additional 5 minutes at 37°C should be sufficient.

10. Follow the program prompts for manual intervention:

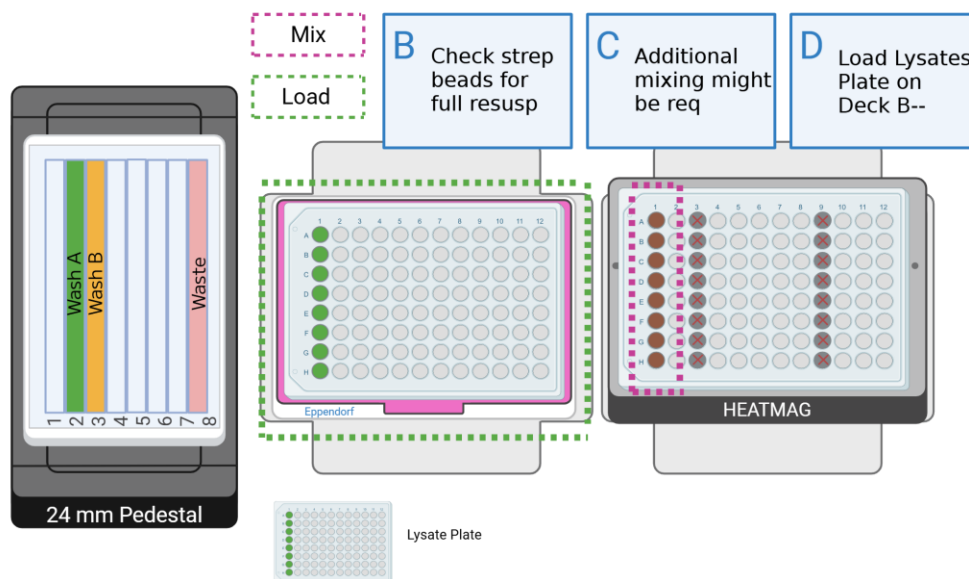

- b. Check streptavidin beads for full resuspension.
- c. If ● Streptavidin Beads are not fully resuspended in the ● Binding Buffer, seal the plate with foil and mix by vortexing at maximum speed. Briefly centrifuge for **10 seconds** at 100 × g before proceeding. Place back on Deck C, remove the seal, and continue.
- d. On Deck B, place the **Lysate Plate** onto the room-temperature Eppendorf Thermochromic Cold Block with well A1 positioned in the upper-left corner. Press "Run" to continue.

11. Follow the program prompts for manual intervention:

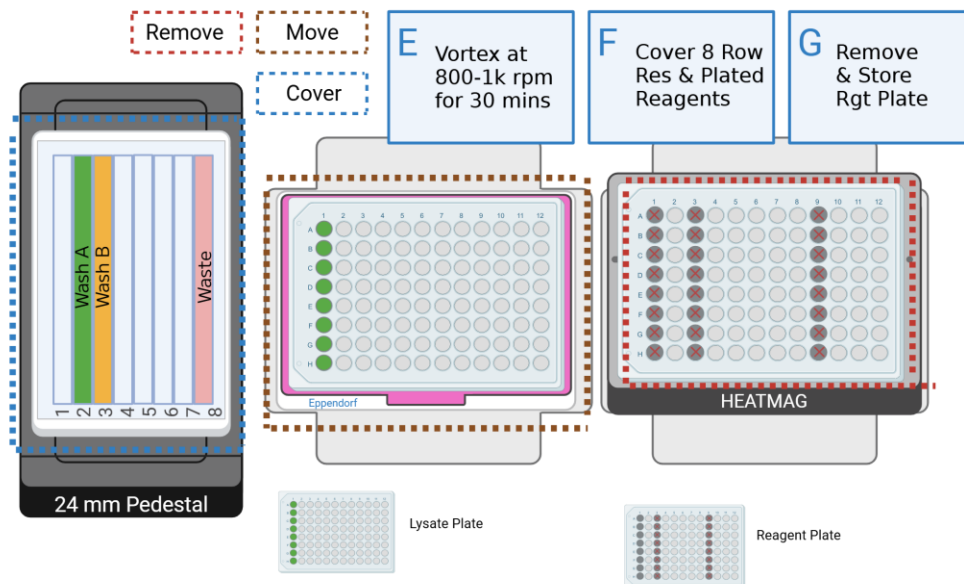

12. Seal **Lysate Plate** with a foil plate seal.

- e. Vortex at 800-1000 rpm for **30 minutes**.
- f. While the **Lysate Plate** is vortexing, cover the 8 Row Reservoir on Deck A and the **Reagent Plate** on Deck C with plastic seals to reduce contamination.
- g. Remove the **Reagent Plate** and store it at room temperature for later use.



Note: To ensure the beads are being mixed sufficiently, check that the beads are in solution 10 minutes into the vortexing. If settled, increase the vortex mixing speed to keep the beads in solution.

13. Press "Run" to complete the program.

2.3. cDNA-Bound Bead Wash

The streptavidin beads with cDNA samples are washed to remove cellular debris.

1. Gather the following reagents:

ITEM	SOURCE	QTY	HANDLING AND STORAGE
VOYAGER Pipetting 8-Ch 5-125 μ L	INTEGRA Component	1	
Tip Deck for VOYAGER Pipetting Module	INTEGRA Component	1	
24 mm Labware Pedestal	INTEGRA Component	1	
Thermochromic PCR Cold Block	Parse	1	Ensure the Thermochromic PCR Cold Block with riser is at room temperature before use.
Thermochromic PCR Cold Block Riser	Parse	1	
HEATMAG with 96 Well Adapter	INTEGRA Component	1	
300 mL Reservoir Base	INTEGRA Component	1	
125 μ L Tip Rack	INTEGRA	1	
SealPlate	Consumables	1	

2. After completion of the 30 minute vortexing, briefly centrifuge the captured **Lysate Plate** for **30 seconds** at 100 x g at 4°C.
3. Unseal and place the **Lysate Plate** back on the HEATMAG with 96 Well Adapter on Deck C with A1 on the upper- left corner.

4. Uncover the **8 Row Reservoir** on Deck A. The deck layout should correspond to the configuration below.

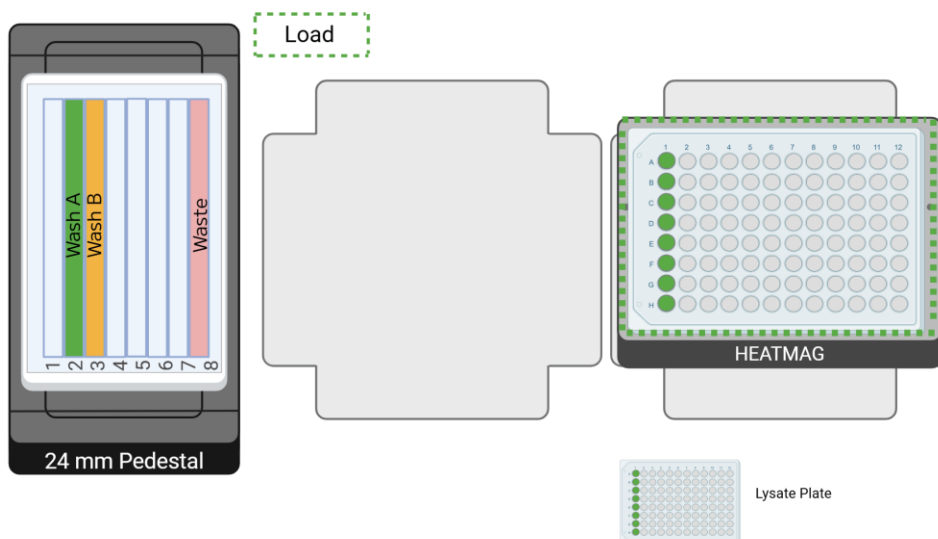

5. Select and run the program **WT S2 St3 V4_0** following the diagram below.

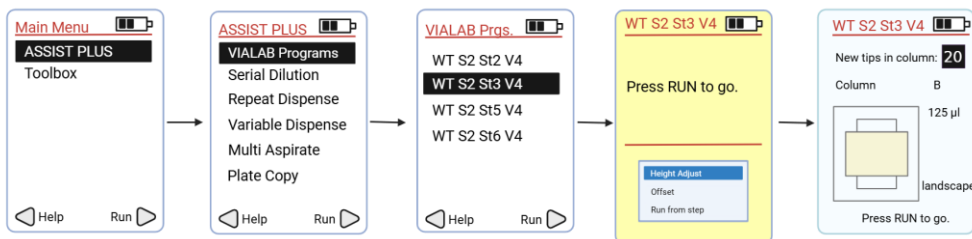

6. At the conclusion of the run:
 - a. Remove the **Lysate Plate**, seal it with a plastic seal, and store it at room temperature for use in later steps.
 - b. Proceed immediately to section 2.4.

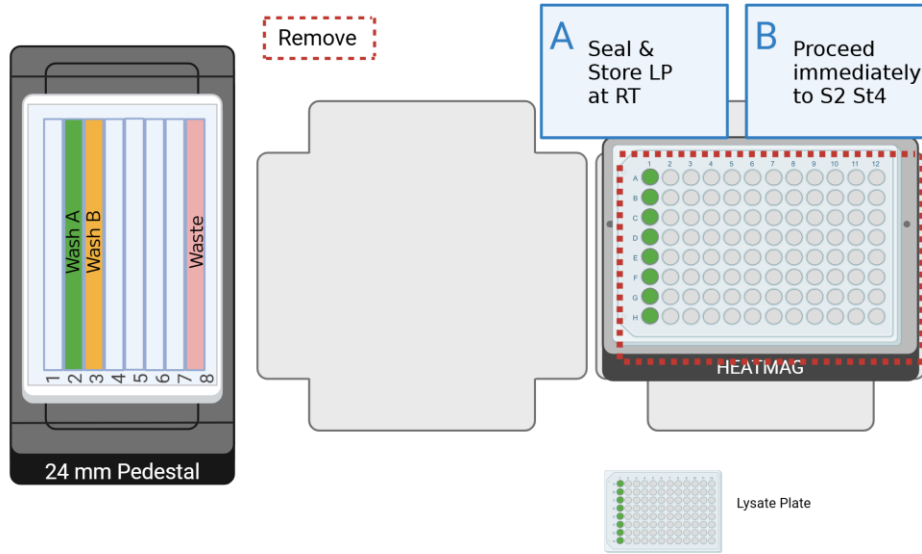

2.4. Master Mixes Preparation

The program prepares the Template Switch Master Mix and the cDNA Amplification Master Mix for the template switch and the cDNA amplification reactions.

To prepare reagents:

1. Gather the following items and handle as indicated below:

ITEM	SOURCE	QTY	HANDLING AND STORAGE
D-ONE Pipetting Module 1-Ch, 5-1250 μ L	INTEGRA Component	1	
Tip Deck for D-ONE Pipetting Module	INTEGRA Component	1	
Parse Metal Cold Block	Parse	1	
24 mm Labware Pedestal	INTEGRA Component	1	
HEATMAG with 96 Well Adapter	INTEGRA Component	1	
300 mL Reservoir Base	INTEGRA Component	1	
8-count PCR strip tubes	Consumables	2	
2 mL tubes	Consumables	2	
125 μ L Tip Rack	INTEGRA	1	
1250 μ L Tip Rack	INTEGRA	1	
● Template Switch Buffer	-20°C Reagents	1	Thaw at room temperature then place on ice. Mix by inverting 3x. Briefly centrifuge before use.
● Template Switch Primer	-20°C Reagents	1	
● Template Switch Enzyme	-20°C Reagents	1	Keep on ice. Briefly centrifuge before use.
● cDNA Amp Mix	-20°C Reagents	1	Thaw at room temperature then place on ice. Mix by inverting 3x. Briefly centrifuge before use.
● cDNA Amp Primers	-20°C Reagents	1	

ITEM	SOURCE	QTY	HANDLING AND STORAGE
● PCR Additive	-20°C Reagents	1	
SPRI Beads	Reagents	1	Equilibrate at room temperature
Nuclease-free water	Reagents	1	



Note: Ensure that there is no precipitate in the ● Template Switch Buffer before proceeding.

2. Set up the deck following the Deck Configuration below.

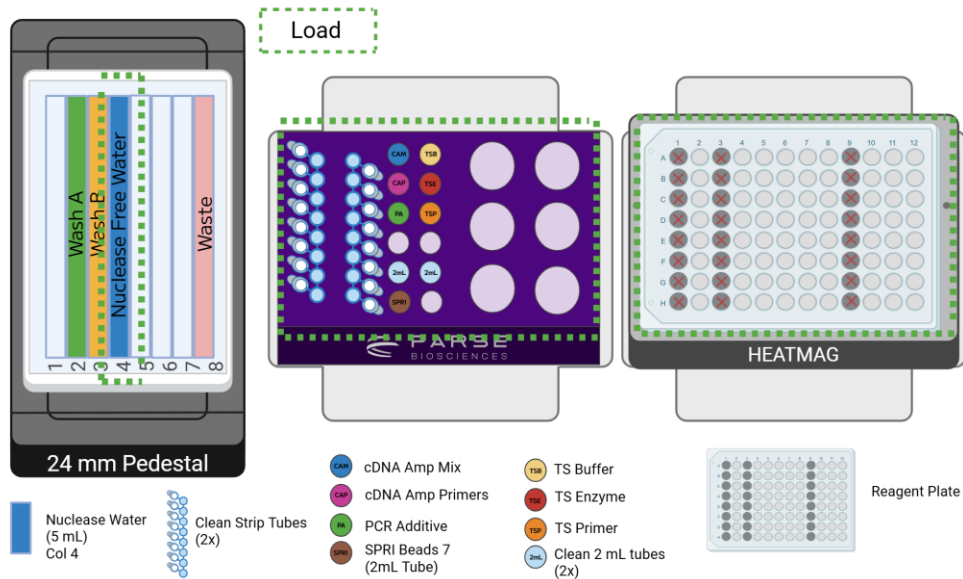
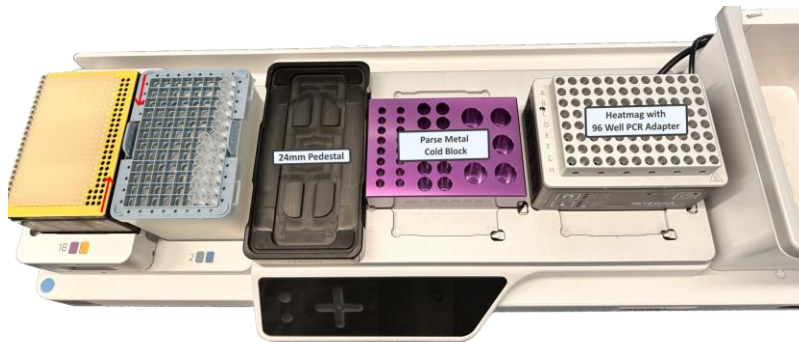

3. Deck A:

a. Fill column 4 of the 8-row reservoir with 5 mL of nuclease-free water.

4. On Deck B, on the Parse Metal Cold Block, place the following consumables and reagents using the deck configuration below:
 - a. Column 1 left and right: two clean 8-count PCR strip tubes with the following labels:
 - i. Left: **cDNA Primer Mix**
 - ii. Right: **cDNA Amp Mix**
 - b. Column 2:
 - i. Pos 1: ● cDNA Amp Mix.
 - ii. Pos 2: ● cDNA Amp Primers.
 - iii. Pos 3: ● PCR Additive.
 - iv. Pos 5: a clean 2 mL tube.
 - v. Pos 6: 850 μ L of SPRI Beads (2 mL tube)
 - vi. Pos 7: ● Template Switch Buffer.
 - vii. Pos 8: ● Template Switch Enzyme.
 - viii. Pos 9: ● Template Switch Primer.
 - ix. Pos 11: a clean 2 mL tube.
5. Deck C: Remove the seal from the **Reagent Plate**, then place the plate on the HEATMAG with the 96-well PCR adapter, with well A1 positioned in the upper-left corner.
6. Change the pipette that is connected to the INTEGRA ASSIST PLUS:
 - a. Remove the VOYAGER 8-Ch 5-125 μ L Pipette and corresponding Tip Deck. Ensure it is disconnected by pressing the back button until the main menu is displayed.
 - b. Replace it with D-ONE Pipetting Module 1-Ch, 5-1250 μ L and corresponding Tip Deck. Ensure the tip deck and tip boxes are securely positioned by pressing them down firmly until they click into place. Remove the tip box lids prior to starting the program.

- Remove the reagent caps, select and run the program **WT S2 St4 V4_0** following the diagram below.



- Press "Run" to continue the program. Follow the program prompts for manual intervention:

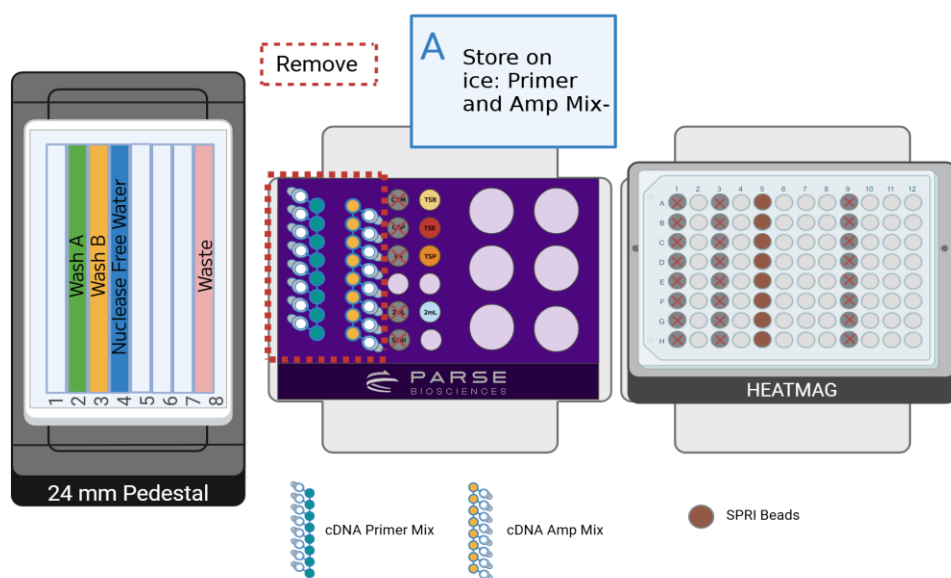

- Remove, cap, and store cDNA Primer Mix and cDNA Amp Mix on ice for later use. Press "Run" to continue.
- At the conclusion of the run:
 - Remove the **Reagent Plate** on Deck C and place on ice. It will be used in the next step.
 - Verify visually that the SPRI bead volume in column 5 of the **Reagent Plate** is even (~90 µL per well).
 - Verify visually that the Template Switch Master Mix volume in column 7 of the **Reagent Plate** is even (~90 µL per well).

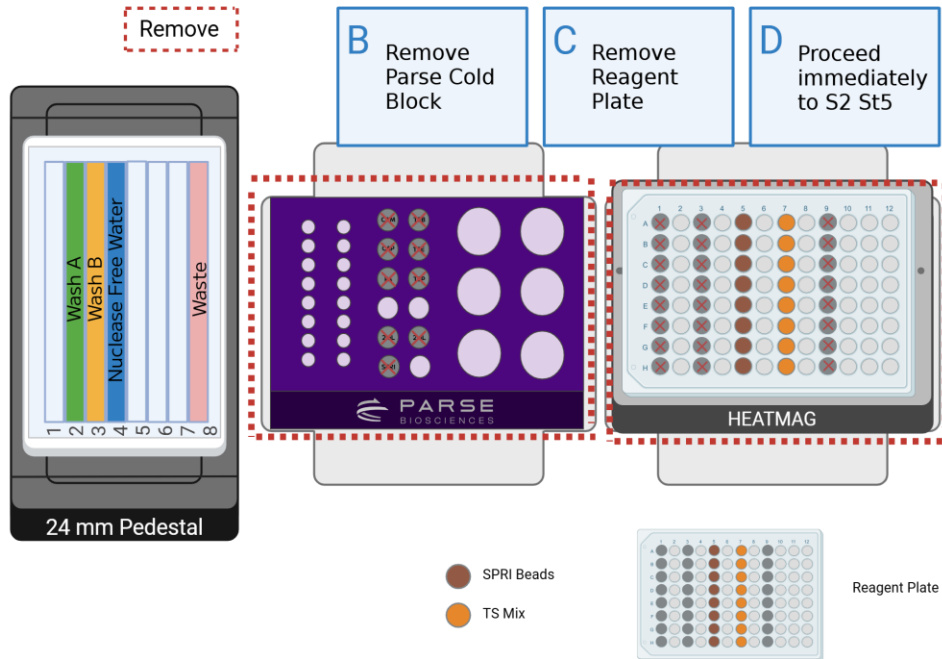

- c. Remove the Parse Metal Cold Block on Deck B and discard used 1.5 mL and 2 mL reagent tubes, column 2.
- b. Proceed immediately to Section 2.5.

2.5. Template Switch and cDNA Amplification

The Template Switch Master Mix is added to the captured cDNA and incubated for 30 minutes. The template switch reaction adds a 5' adapter to the cDNA.

To perform template switch:

1. Gather the following items and set up the deck indicated:

ITEM	SOURCE	QTY	HANDLING AND STORAGE
VOYAGER 8-Ch 5-125 μ L	INTEGRA Component	1	
Tip Deck for VOYAGER Pipetting Module	INTEGRA Component	1	
Thermochromic PCR Cold Block	Parse	1	Ensure the Thermochromic PCR Cold Block with riser is at room temperature before use.
Thermochromic PCR Cold Block Riser	Parse	1	
24 mm Labware Pedestal	INTEGRA Component	1	
HEATMAG with 96 Well Adapter	INTEGRA Component	1	
300 mL Reservoir Base	INTEGRA Component	1	
125 μ L Tip Rack	INTEGRA	1	
SealPlate	Consumables	As needed	

2. Set up the deck following the Deck Configuration below.



3. Ensure the following are loaded following the deck configuration below:

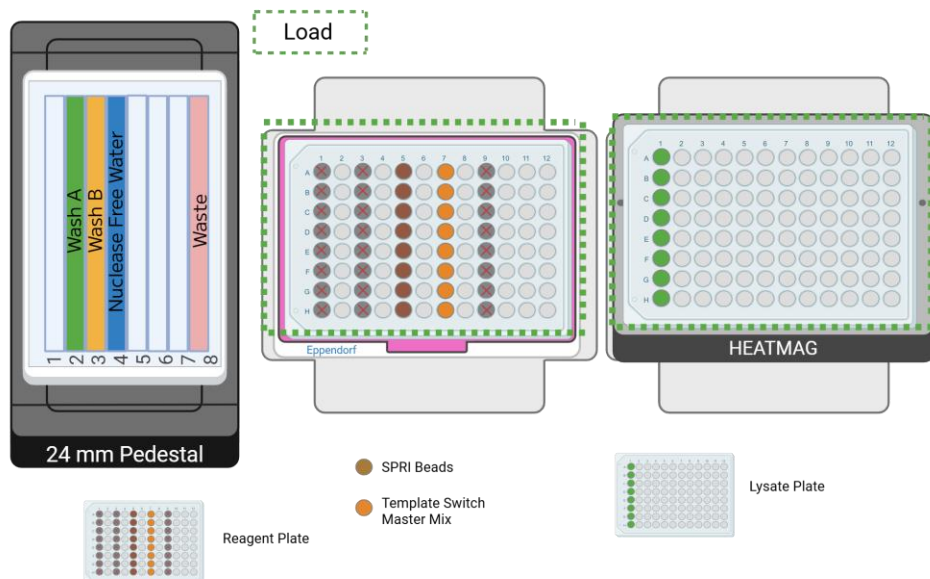

- a. Deck B: **Reagent Plate** on a room temperature Thermochromic PCR Cold Block with Riser with A1 on the upper-left corner.
 - b. Deck C: **Lysate Plate** on the HEATMAG with 96 Well PCR Adapter with A1 on the upper-left corner.
4. Change the pipette that is connected to the INTEGRA ASSIST PLUS:
- a. Remove D-ONE Pipetting Module 1-Ch, 5-1250 μ L and corresponding Tip Deck. Ensure it is disconnected by pressing the back button until the main menu is displayed.
 - b. Replace it with VOYAGER 8-Ch 5-125 μ L Pipette and corresponding Tip Deck. Ensure the Tip Deck and Tip Box are securely positioned by pressing them down firmly until they click into place. Remove the tip box lid prior to starting the program.
5. On the VOYAGER Pipette select and run the program **WT S2 St5 V4_0** following the diagram below.

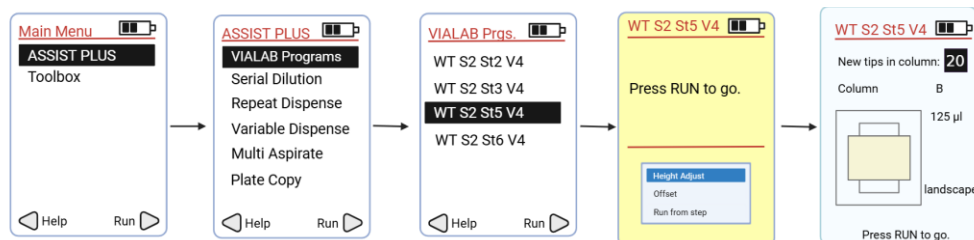

6. Press "Run" to continue the program. Follow the program prompts for manual intervention:

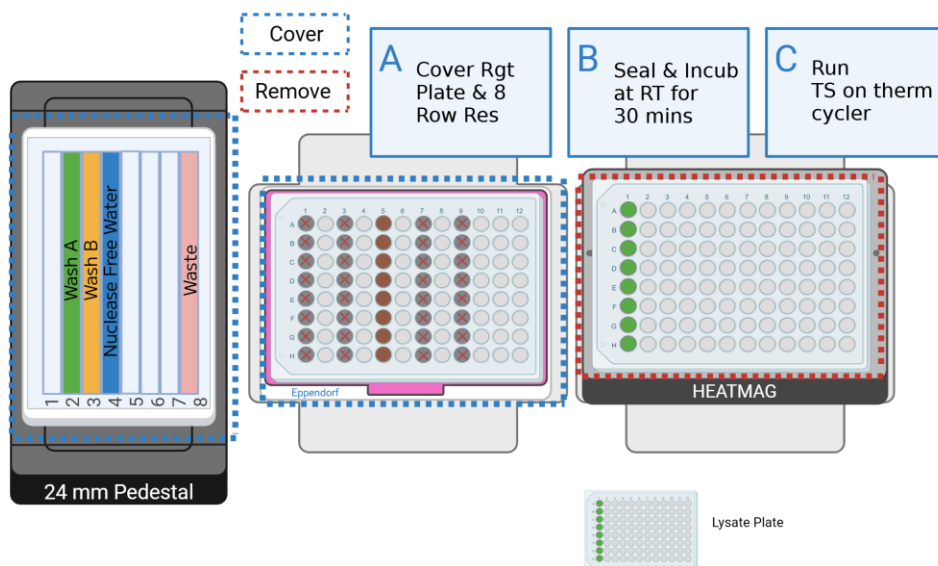

- a. Cover the **Reagent Plate** on Deck B and 8 Row Reservoir on Deck A with plastic seals to prevent contamination.
- b. Seal with a plastic seal and incubate the **Lysate Plate** on Deck C at room temperature for **30 minutes**.
 - i. After the 30 minute incubation, visually inspect the **Lysate Plate** for settled beads. If beads have settled, manually resuspend the samples by mixing 5x with a multichannel P200 pipette set to 80 μ L.
- c. Place the **Lysate Plate** into a thermocycler. Run the following program.

TEMPLATE SWITCH		
Run Time	60 minutes	
Lid Temperature	70°C	
Sample Volume	100 μ L	
Step	Time	Temperature
1	60 min	42°C
2	Hold	4°C

7. While the Template Switch thermocycler is running, press "Run" to continue the program on the Assist Plus. Follow the program prompts for manual intervention:

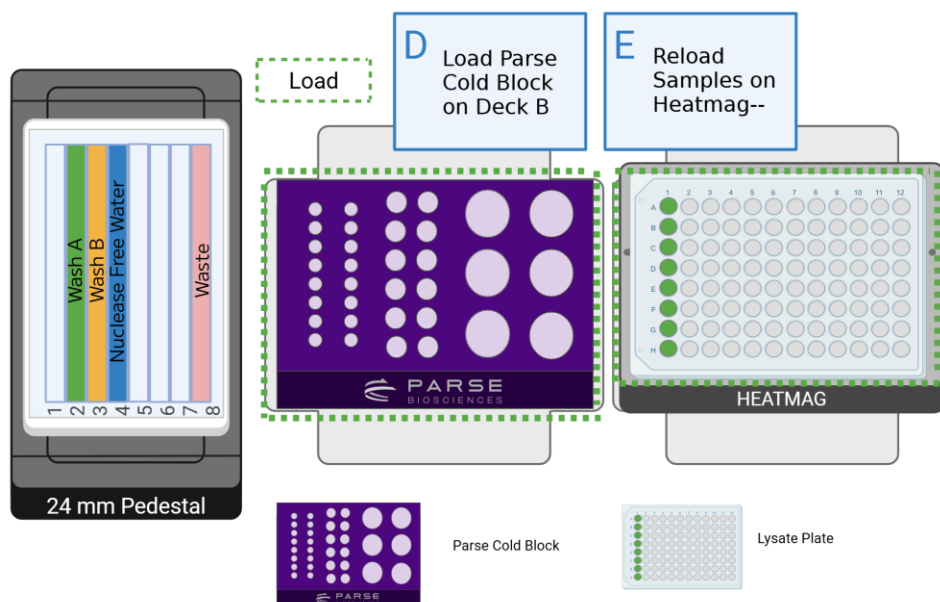

- d. Remove the Thermochromic Cold Block and load the Parse Metal Cold Block on Deck B with the PCR tubes on the left.
- e. When the Template Switch thermocycling program has completed:
- i. Remove the plate seal from the 8 Row reservoir on Deck A.
 - ii. Reload the **Lysate Plate** on the HEATMAG on Deck C with A1 in the upper-left corner. Remove the plate seal.

8. Press "Run" to continue the program. Follow the program prompts for manual intervention:

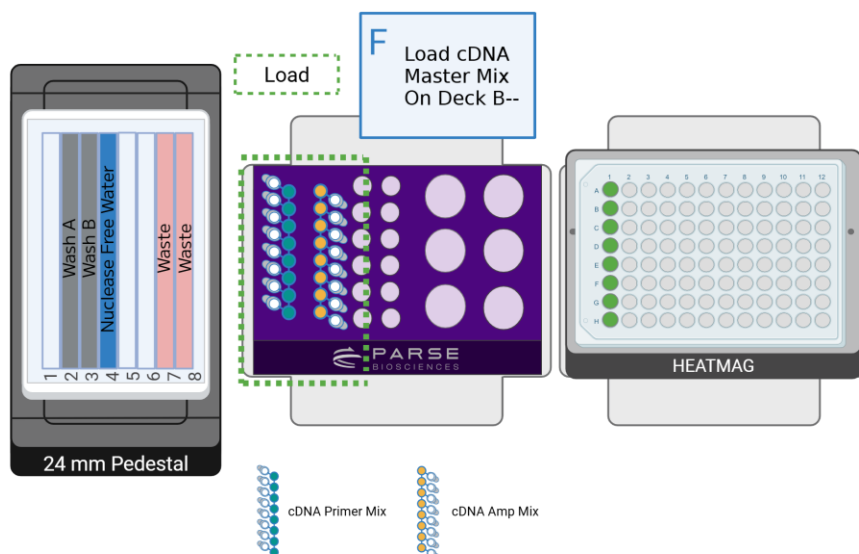

- f. On Deck B, Column 1:
 - i. Left: uncap and load **cDNA Primer Mix**.
 - ii. Right: uncap and load **cDNA Amp Mix**.
9. Press "Run" to continue the program. Follow the program prompts for manual intervention:

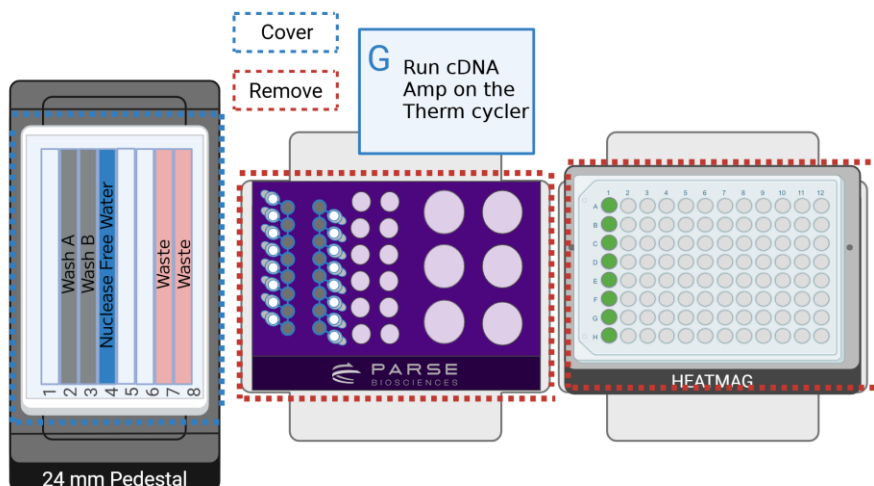

10. Remove and seal the **Lysate Plate** with a plastic seal on Deck C.

11. Use the guidelines below to amplify the cDNA samples on the **Lysate Plate**.
12. Determine the number of PCR cycles required for cDNA amplification based on the table below. Although these recommendations are appropriate for many cell types, the number of cycles may need to be optimized for each sample type.

NUMBER OF PCR CYCLES			
Cells/nuclei in the Sublibrary	High RNA content such as cell lines	Low RNA content such as PBMCs	Nuclei
200-1,000	11	13	12
1,000-2,000	9	11	10
2,000-6,000	7	9	8
6,000-12,500	6	8	7

cDNA AMPLIFICATION			
Run Time		50-70 minutes	
Lid Temperature		105°C	
Sample Volume		100 µL	
Step	Time	Temperature	Cycle
1	3 min	95°C	1
2	20 sec	98°C	5
3*	45 sec	65°C*	
4	3 min	72°C	
5	20 sec	98°C	Variable, see above
6*	20 sec	67°C*	
7	3 min	72°C	
8	5 min	72°C	1
9	Hold	4°C	1



CRITICAL! If processing sublibraries with different numbers of cells or nuclei, amplify them in separate thermocyclers according to the recommendations above. Transfer samples requiring higher cycle numbers to a separate plate, maintaining the same well positions. After thermal cycling, transfer the samples back into their corresponding wells in the original **Lysate Plate**.



Note: Annealing steps 3* and 6* have different time and temperature settings. Ensure these are correct before starting the program.

13. While the thermocycler program is running:

- a. Remove the Parse Metal Cold Block and discard used strip tubes on Deck B.
- b. Cover the 8 Row Reservoir with a plastic seal during this time to reduce contamination.
- c. If not stopping, proceed to Section 2.6 while the cDNA Amp thermocycler program is running.

 Safe stopping point: **Amplified cDNA** can be stored at 4°C for up to 18 hours. Covered 8 Row Reservoirs and the **Reagent Plate** can also be stored at room temperature for up to 18 hours.

2.6. Post-Amplification Purification

Amplified cDNA is purified with a 0.8x SPRI bead cleanup.

To purify the cDNA:

1. Gather the following items and set up the deck as indicated:

ITEM	SOURCE	QTY	HANDLING AND STORAGE
VOYAGER 8-Ch 5-125 μ L	INTEGRA Component	1	
Tip Deck for VOYAGER Pipetting Module	INTEGRA Component	1	
Thermochromic PCR Cold Block	Parse	1	Ensure the Thermochromic PCR Cold Block with riser is at room temperature before use.
Thermochromic PCR Cold Block Riser	Parse	1	
24 mm Labware Pedestal	INTEGRA Component	1	
HEATMAG with 96 Well Adapter	INTEGRA Component	1	
300 mL Reservoir Base	INTEGRA Component	1	
125 μ L Tip Rack	INTEGRA	1	
96 well Semi-Skirted Plate	Consumables	1	
SealPlate®	Consumables	As needed	
TempPlate Sealing® Foil	Consumables	As needed	
Ethanol, 85%	Reagents	1	Prepare 85% Ethanol by using 200 proof Ethanol and nuclease-free water. Make fresh the day it is needed.
Nuclease free water	Reagents	1	
SPRI Beads	Reagents	1	

- Set up the deck following the Deck Configuration below.



- Prepare at least **5 mL** 85% ethanol with nuclease-free water.
- Remove the seal and add **5 mL** 85% ethanol in column **5** of the 8 Row Reservoir on Deck A.
- Remove the seal and load the **Reagent Plate** onto the room temperature Thermochromic PCR Cold Block with Riser on Deck B, with well A1 positioned in the upper-left corner.
 - Visually inspect the Reagent Plate for settled SPRI beads. If beads have settled, manually resuspend the beads by mixing 5x with a multichannel P200 pipette set to 60 μ L.
- Once the cDNA Amplification thermocycler program is complete, unseal and load the **Lysate Plate** on the HEATMAG with the 96-well PCR adapter on Deck C, with well A1 positioned in the upper-left corner.

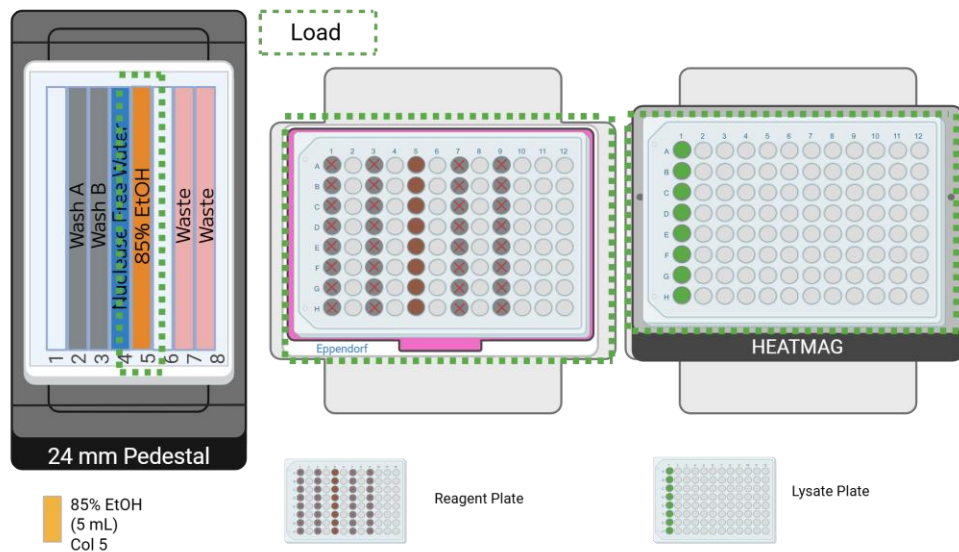

7. Select and run program **WT S2 St6 V4_0** following the diagram below.

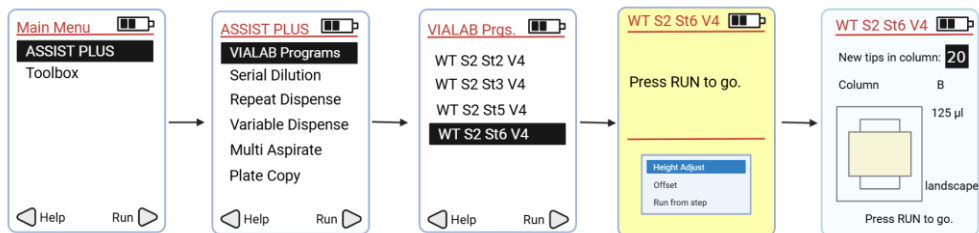

8. Press "Run" to continue the program. Follow the program prompts for manual intervention:

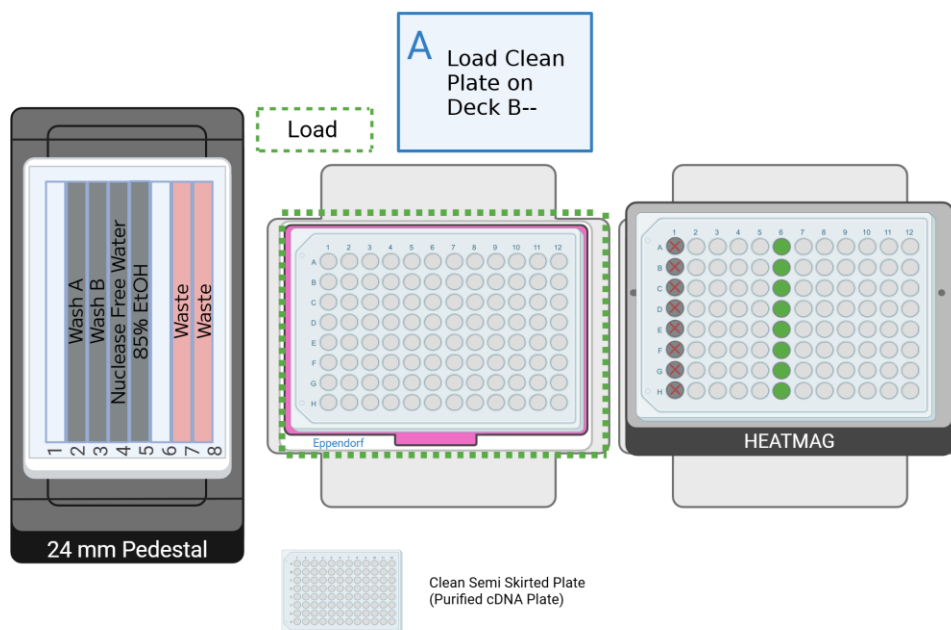

- Remove the **Reagent Plate** from Deck B.
- Load a clean Eppendorf semi-skirted plate labeled "**Purified cDNA**" onto the room temperature ThermoChromic PCR Cold Block with Riser on Deck B.
- Press "Run" to continue the program.

9. At the conclusion of the run:

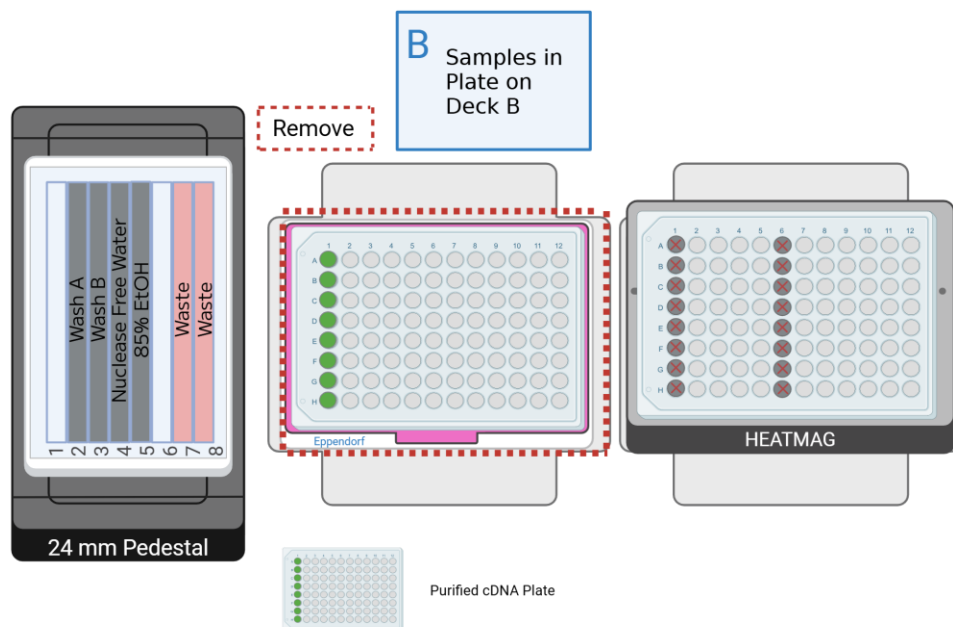

10. The **Purified cDNA** will be on Deck B. Seal the plate with a foil plate seal, then add a plastic plate seal on top of the foil plate seal. Alternatively, proceed directly to Section 2.7 to quantify the cDNA before continuing to Section 3. Seal the **Purified cDNA** plate after taking aliquots to QC.

Safe stopping point: **Purified cDNA** can be stored at 4°C for up to 48 hours or at -20°C for up to 3 months.



CRITICAL! In Section 3, you will need two ThermoChromic PCR Cold Blocks with ThermoChromic PCR Cold Block Risers. One block should remain cold throughout the process, while the other should be at room temperature. We recommend either leaving one block at room temperature overnight to thaw before starting, or running it under warm water to thaw quickly on the morning of Section 3.

2.7. cDNA Quantification

The concentration and size distribution of the cDNA are measured with fluorescent dyes and capillary electrophoresis. The cDNA is then stored at 4°C for up to 48 hours or at -20°C for up to 3 months.

To quantify the cDNA:

1. Measure the concentration of each tube of purified cDNA from Section 2.6 with the Qubit dsDNA HS (High Sensitivity) Assay Kit according to the manufacturer's instructions. Record the concentrations, which will be used in Section 3.
2. Assess the size distribution of each tube of purified cDNA with a High Sensitivity DNA Kit on the Agilent Bioanalyzer System or High Sensitivity D5000 ScreenTape and Reagents on the Agilent TapeStation System according to the manufacturer's instructions.



Safe stopping point: purified cDNA can be stored at 4°C for up to 48 hours or at -20°C for up to 3 months. Otherwise, proceed immediately to Section 3.

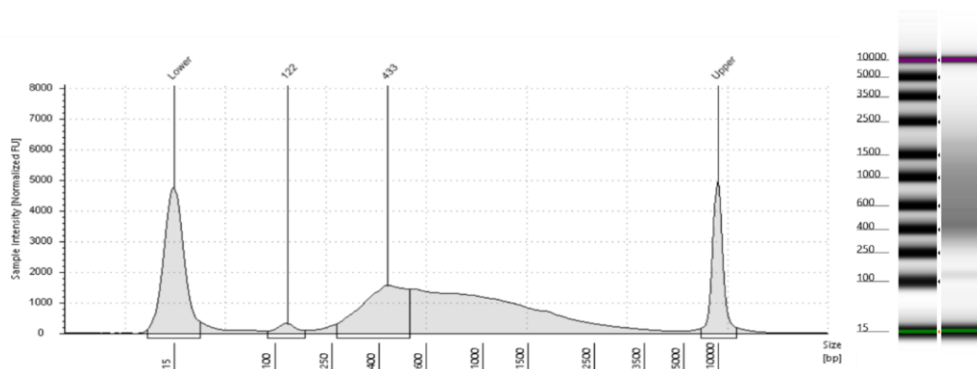

Figure 8: Expected post-amplification sublibrary cDNA size distribution. Example trace of Human cDNA run on a TapeStation.

Note: Samples may need to be diluted to be within the manufacturer's recommended concentration range. Typically, between a 1:3 to 1:10 dilution or 3-5 ng are appropriate.



Note: The traces above are representative of typical TapeStation cDNA traces. The shape and prominence of the trace is dependent on cell type, sublibrary size, and amount of DNA loaded into the TapeStation. Sublibraries with minor deviations can still produce high quality data.

Section 3: Sequencing Library Preparation

3.0. cDNA Normalization (Optional)

Prior to starting Section 3, cDNA can optionally be normalized to ensure that all sublibraries fall within the same amplification condition. It is advantageous to have all sublibraries use the same amplification condition to remove the need for splitting between multiple thermal cyclers during amplification. The program uses nuclease free water on Deck A to normalize amplified cDNA on Deck B.

If choosing NOT to normalize amplified cDNA:

Manually prepare Diluted cDNA in column 1 of a Semi-Skirted 96 Well PCR Plate as follows to a final volume of 35 μ L and store on ice. Label this plate as your cDNA Sample plate and store on ice.

DILUTED cDNA	
Purified cDNA	10 μ L
Nuclease-free water	25 μ L
Total Volume	35 μ L

The remaining cDNA samples from the **Purified cDNA** plate can be stored at -20°C . Seal the plate with a foil plate seal, add a plastic plate seal on top of the foil plate seal, then place at -20°C .

If choosing to normalize amplified cDNA:

1. Gather the following items and handle as indicated below:

ITEM	SOURCE	QTY	HANDLING AND STORAGE
D-ONE Pipetting Module 1-Ch, 5-1250 μ L	INTEGRA Component	1	
Tip Deck for D-ONE Pipetting Module	INTEGRA Component	1	
Parse Metal Cold Block	Parse	1	
Thermochromic PCR Cold Block	Parse	1	Pull the Thermochromic PCR Cold Block with riser from the -20°C freezer and leave them at room temperature for 10 minutes prior to use.
Thermochromic PCR Cold Block Riser	Parse	1	

ITEM	SOURCE	QTY	HANDLING AND STORAGE
24 mm Labware Pedestal	INTEGRA Component	1	
HEATMAG with 96 Well Adapter	INTEGRA Component	1	
Semi-Skirted 96 Well PCR Plate	Consumables	1	
125 μ L Tip Rack	INTEGRA	1	
1250 μ L Tip Rack	INTEGRA	1	
2 mL tube	Consumables	1	
SealPlate®	Consumables	1	
TempPlate Sealing® Foil	Consumables	1	
Nuclease free water	Reagents	1	

2. If frozen, thaw the **Purified cDNA** plate and store it on ice.
3. Download the Parse Biosciences Evercode WT v4 Integra Normalization file. The most current version can be found on the [Parse Biosciences Customer Support Suite](#).
4. Obtain recorded cDNA concentrations from Section 2.7.
5. Fill out the following cells of the Parse Biosciences Evercode Mega/WT Integra Normalization v4.0.xlsm. Target sample volume should be around 10 μ L (Figure 8).
 - a. Sample
 - b. Source Well
 - c. Concentration (ng/ μ L)
 - d. Library Input (ng)



Note: If any parameter is out of range, the cells will turn pink in color and/or an error message will appear. Be sure to address and adjust worksheet input values appropriately before continuing.

Parse Biosciences
 700 Dexter Ave
 Suite 600
 Seattle, WA 98109

 Support Suite: support.parsebiosciences.com
 Email: support@parsebiosciences.com
 WT Mega - Version 2.0

Evercode WT cDNA Normalization Loading Table

- For more details on using this cDNA Normalization Loading Table, see the Important Guidelines section of the User Manual

This sheet should be filled out prior to starting Section 3.

Step	Instructions
1	Ensure Macros are enabled.
4	Input your sample names.
6	Input source well location.
6	Input destination well location.
6	Input cDNA concentration in ng/ul.
7	Input total ng library prep input.
8	CRITICAL: Ensure Sample Volume (uL) is between 4 to 25 uL.
9	Open the "Integra Loading Table" sheet. Click on the "Generate a cDNA Normalization w/orklist for Import into VIALAB" to generate the worklist file.

Number of PCR Cycles	
cDNA Input (ng)	PCR Cycles
10-24	13
25-49	12
50-99	11

Number of PCR Cycles	
cDNA Input (ng)	PCR Cycles
100-299	10
300-999	9
1,000 or more	7

Sample	Source Well	Destination Well	Conc. (ng/ul)	Library Input (ng)	Sample Volume (ul)	Diluent Volume (ul)
	A1	A1				
	B1	B1				
	C1	C1				
	D1	D1				
	E1	E1				
	F1	F1				
	G1	G1				
	H1	H1				

Figure 9: Evercode WT cDNA normalization loading table.

- Navigate to the "INTEGRA Loading Table" tab on the excel sheet, and click on "Generate a cDNA Normalization Worklist for Import". Save the generated CSV file (called Section3NormWTWorksheet_XXXXXX_XXXXXX.csv) (Figure 10).

SampleID	SourceDeckPosition	SourceWell	TargetDeckPosition	TargetWell	TransferVolume [ul]	Tip Type
a	B2	F2	C1	A1	2	125
b	B2	F2	C1	B1	24.6	125
c	B2	F2	C1	C1	9.7	125
d	B2	F2	C1	D1	21.2	125
e	B2	F2	C1	E1	8.8	125
f	B2	F2	C1	F1	23.6	125
i	B2	F2	C1	A2	22.1	125
j	B2	F2	C1	B2	20.8	125
k	B2	F2	C1	C2	15.7	125
l	B2	F2	C1	D2	27.7	125
a	B1	A1	C1	A1	33	125
b	B1	B1	C1	B1	10.4	125
c	B1	C1	C1	C1	25.3	125
d	B1	D1	C1	D1	13.8	125
e	B1	E1	C1	E1	26.2	125
f	B1	F1	C1	F1	11.4	125
i	B1	A2	C1	A2	12.9	125
j	B1	B2	C1	B2	14.2	125
k	B1	C2	C1	C2	19.3	125
l	B1	D2	C1	D2	7.3	125



Figure 10: Generated cDNA normalization worklist.

- Open the VIALAB program **WT S3 St0 V4_0 DONE** and navigate to the "Method" section. In the "O2 Worklist", under the "Worklist and Volumes" tab, import the "Section3NormWTWorksheet_XXXXXX_XXXXXX.csv" worklist file generated in the previous step. The "Import" button is located in the upper left of the Worklist and Volumes tab (Figure 11).

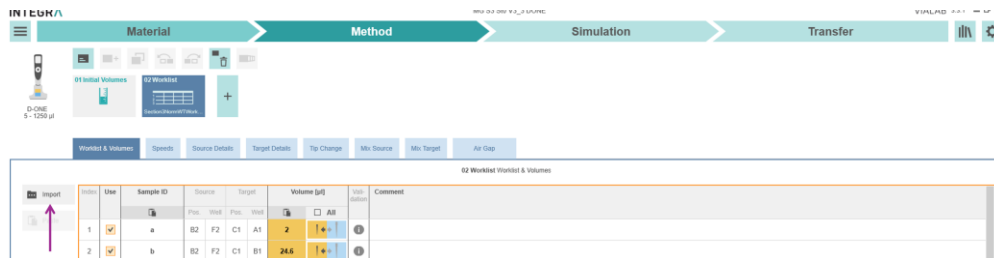
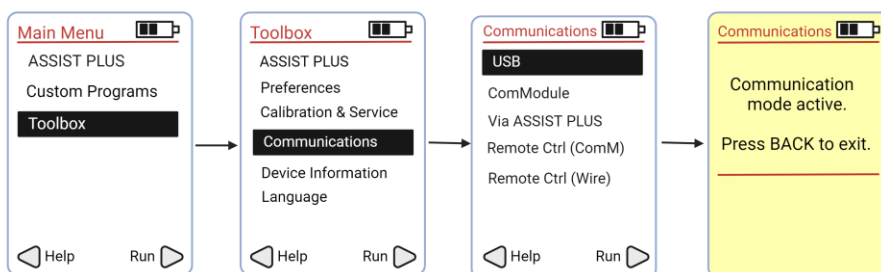

Figure 11: VIALAB worklist generation for diluent volumes using O2 Worklist.

8. Save and transfer your program to your D-ONE Pipetting Module (1-Ch, 5-1250 µL) as follows:
 - a. Connect your computer with the D-ONE Pipette using Communication/Charging.
 - b. Follow the instructions on the pipette menu, as shown in the diagram below:



- c. In the VIALAB software on your computer, select "Transfer".
- d. Confirm that the pipette has been recognized by the software. Click "Send to pipette". An audible signal will indicate the successful upload of the **WT S3 St0 V4_0** program to the D-ONE Pipette.
- e. Disconnect the cable and proceed with the protocol on the INTEGRA ASSIST PLUS platform.
- f. A program named **WT S3 St0 V4_0** will be found on your pipette.



CRITICAL! Delete any previous scripts from the D-ONE pipette to avoid running incorrect scripts.

9. Set up the deck following the deck configuration below.



10. Set up the deck layout following the Deck Configuration below:

- a. Deck A: Parse Metal Cold Block on 24mm Labware Pedestal
 - i. Column 2, position 7: **1.8 mL** nuclease-free water in a 2 mL tube
- b. Deck B: Briefly vortex and centrifuge the **Purified cDNA** plate, remove the seal, and place it on the ThermoChromic PCR Cold Block with A1 in the upper left corner, pressing firmly to ensure the plate is fully seated.
- c. Deck C: Place a clean semi-skirted plate on the HEATMAG with 96 Well Adapter with A1 in the upper left corner, pressing firmly to ensure the plate is fully seated. Label the plate as **cDNA Sample** plate.

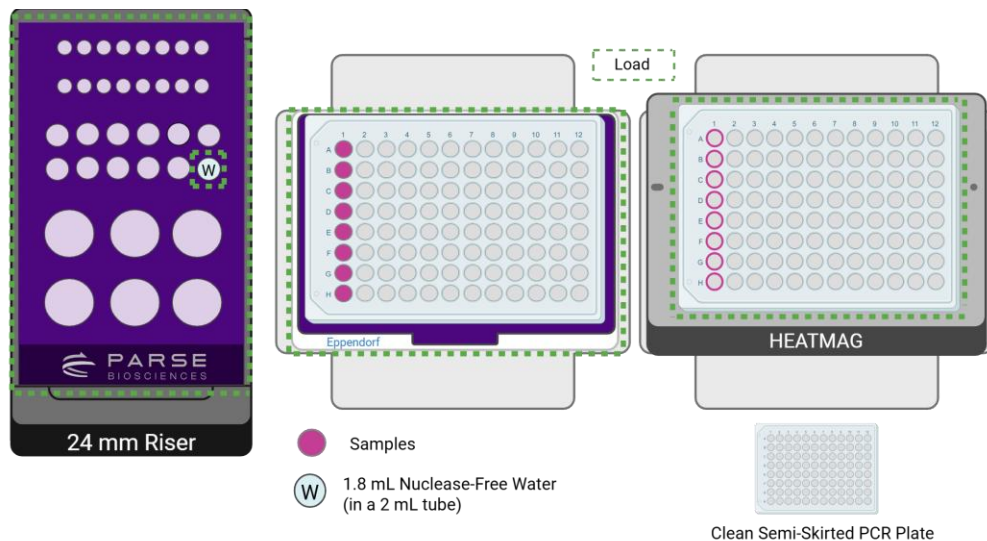

11. If needed, change the pipette:

- Remove the VOYAGER 8-Ch 5-125 μ L Pipette and corresponding Tip Deck. Ensure it is disconnected by pressing the back button until the main menu is displayed.
- Replace it with D-ONE Pipetting Module 1-Ch, 5-1250 μ L Pipette and corresponding Tip Deck. Ensure the tip deck and tip boxes are securely positioned by pressing them down firmly until they click into place. Remove the tip box lids prior to starting the program.

12. Select and run program **WT S3 St0 V4_0** following the diagram below.



13. At the conclusion of the run:

- The remaining cDNA samples from the **Purified cDNA** plate on Deck B can be stored at -20°C . Seal the plate with a foil plate seal, add a plastic plate seal on top of the foil plate seal, then place at -20°C .
- Tb. Seal the **cDNA Sample** plate on Deck C with a plastic plate seal and store on ice. It will be used in Section 3.2.

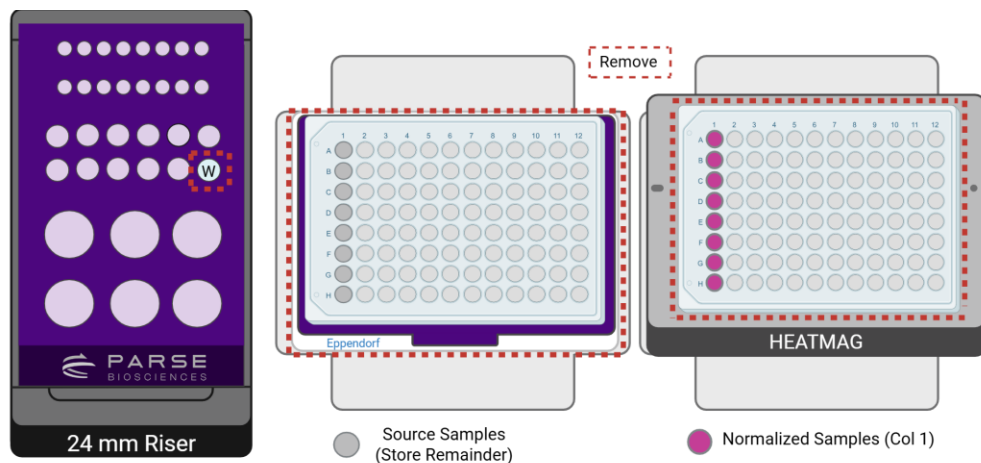

3.1. SPRI Bead Plating

The SPRI beads are aliquoted to be used throughout all of Section 3. Aliquots can then be quickly accessed via multichannel pipette when needed. SPRI beads should be kept at room temperature.

1. Gather the following components and reagents:

ITEM	SOURCE	QTY	HANDLING AND STORAGE
D-ONE Pipetting Module 1-Ch, 5-1250 μ L	INTEGRA Component	1	
Tip Deck for D-ONE Pipetting Module	INTEGRA Component	1	
Thermochromic PCR Cold Block	Parse		Pull the Thermochromic PCR Cold Block with riser from the -20°C freezer and leave them at room temperature for 10 minutes prior to use.
Thermochromic PCR Cold Block Riser	Parse		
Parse Metal Cold Block	Parse	1	
24 mm Labware Pedestal	INTEGRA Component	1	
HEATMAG with 96 Well Adapter	INTEGRA Component	1	
Semi-Skirted 96 Well PCR Plate	Consumables	1	
2 mL tube	Consumables	1	
125 μ L Tip Rack	INTEGRA	1	
1250 μ L Tip Rack	INTEGRA	1	
SealPlate	Consumables	as needed	
SPRI Beads	Reagents		

2. If not connected already, connect the D-ONE Pipetting Module 1-Ch, 5-1250 μ L Pipette and corresponding Tip Deck. Ensure the tip deck and tip boxes are securely positioned by pressing them down firmly until they click into place. Remove the tip box lids prior to starting the program.
3. Load the 24 mm Labware Pedestal on Deck A.

4. If not connected already, connect the HEATMAG on Deck C.
5. Move the Parse Metal Cold Block onto the 24 mm Labware pedestal on Deck A. The deck layout should correspond to the configuration below:



6. Ensure the following are loaded, using the deck configuration below:
 - a. Deck A column 1:
 - i. Pos 6: a 2mL tube with **1,800 μ L** fully resuspended SPRI beads. Visually inspect the 2 mL tube for settled SPRI beads. If beads have settled, manually resuspend the beads by mixing 5x with a multichannel P1000 pipette set to 1000 μ L prior to loading them on the Parse Metal Cold Block.
 - b. Deck C: clean semi-skirted 96 well PCR plate.

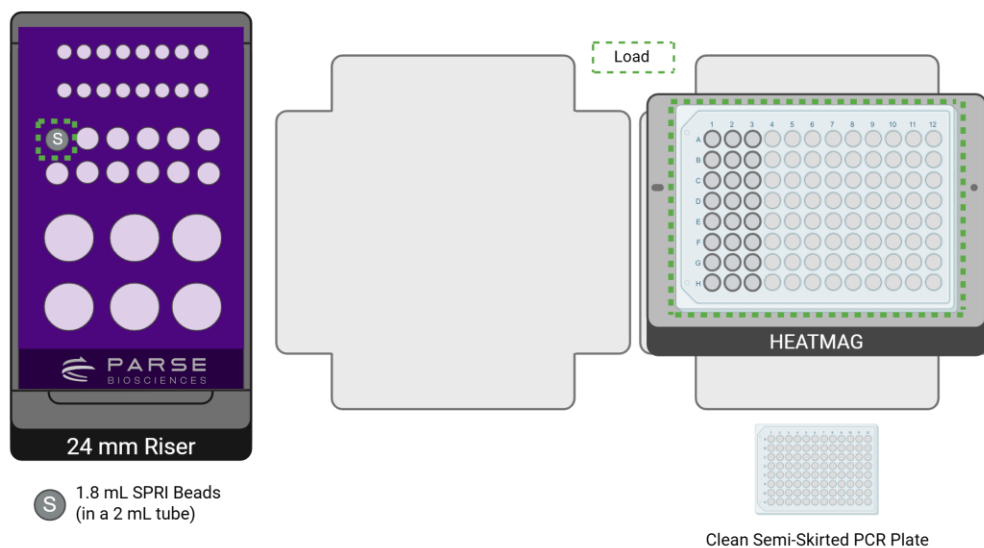

7. Select and run the program **WT S3 St1 V4_0** following the diagram below.



8. Wait for the program to complete.
9. After pressing “Run” remove a ThermoChromic PCR Cold Block with riser from the -20°C to thaw at room temperature for 10 minutes. This will be used in Section 3.2.
10. At the conclusion of the run:
 - a. Leave the D-ONE pipette connected to the instrument.
 - b. Label the 96-well plate on Deck C as **Reagent Plate S3**. If proceeding immediately to Section 3.2, leave the **Reagent Plate S3** on the HEATMAG. Otherwise, remove the **Reagent Plate S3**, seal with a PCR plate seal, and keep it aside at room temperature.
 - c. Discard the used tube on Deck A. Remove and store the Parse Metal Cold Block on ice.

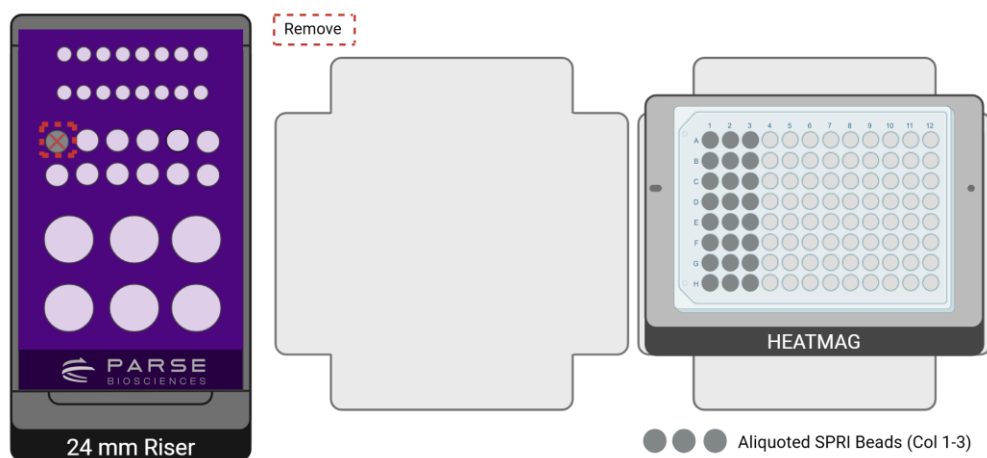

3.2. Fragmentation Mix Creation and Plating

The program makes the Fragmentation Mix and aliquots out the mix such that it can be easily pipetted into sublibraries using the multichannel pipette.

1. Gather the following components and reagents:

ITEM	SOURCE	QTY	HANDLING AND STORAGE
D-ONE Pipetting Module 1-Ch, 5-1250 μ L	INTEGRA Component	1	
Tip Deck for D-ONE Pipetting Module	INTEGRA Component	1	
Parse Metal Cold Block	Parse	1	
24 mm Labware Pedestal	INTEGRA Component	1	
Thermochromic PCR Cold Block	Parse	1	Pull the Thermochromic PCR Cold Block with riser from the -20°C freezer and leave them at room temperature for 10 minutes prior to use.
Thermochromic PCR Cold Block Riser	Parse	1	
HEATMAG with 96 Well Adapter	INTEGRA Component	1	
Semi-Skirted 96 Well PCR Plate	Consumables	1	
125 μ L Tip Rack	INTEGRA	1	
1250 μ L Tip Rack	INTEGRA	1	
1.5 mL tube	Consumables	1	
● Fragm/End Prep Buffer	-20°C Reagents	1	Thaw at room temperature then store on ice.
● Fragm/End Prep Enzymes	-20°C Reagents	1	Place directly on ice. Briefly centrifuge before use.

2. If not already connected, connect the D-ONE Pipetting Module 1-Ch, 5-1250 μ L Pipette and corresponding Tip Deck. Ensure the tip deck and tip boxes are securely positioned by pressing them down firmly until they click into place. Remove the tip box lids prior to starting the program.

3. If not done already, remove both Thermochromic PCR Cold Block with Riser from -20°C and thaw at room temperature for **10 minutes**.
4. Place the Thermochromic PCR Cold Block with Riser on Deck B.
5. Place the cooled Parse Metal Cold Block on the 24 mm Labware Pedestal on Deck A. The deck layout should correspond to the configuration below:

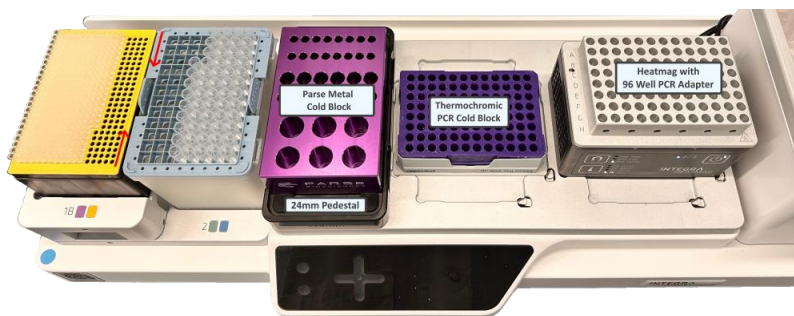

6. Place the following components using the deck configuration below:
 - a. Deck A, column 1:
 - i. Pos 1: a clean 1.5 mL tube.
 - ii. Pos 2: ● Fragm/End Prep Enzymes.
 - iii. Pos 3: ● Fragm/End Prep Buffer.
 - b. Transfer the **cDNA Sample** plate stored on ice from Section 3.0 to the Thermochromic PCR Cold Block on Deck B with A1 in the upper left corner, pressing firmly to ensure the plate is fully seated. If you have not generated a **cDNA Sample** Plate, please refer back to Section 3.0.
 - c. If it was set aside, place the **Reagent Plate S3** (containing SPRI beads) back on Deck C.

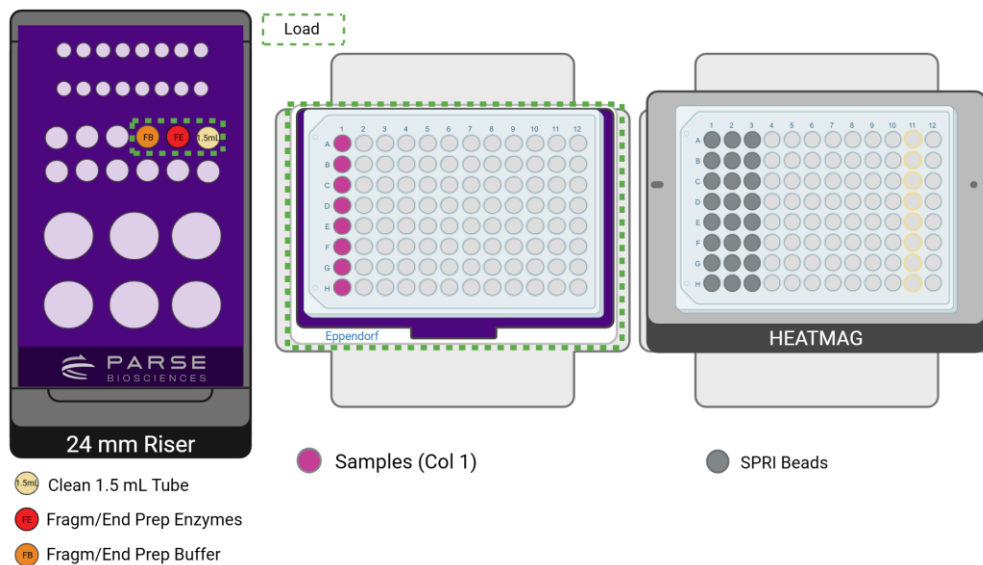

- Remove the reagent caps, then select and run the program **WT S3 St2 V4_0** following the diagram below.

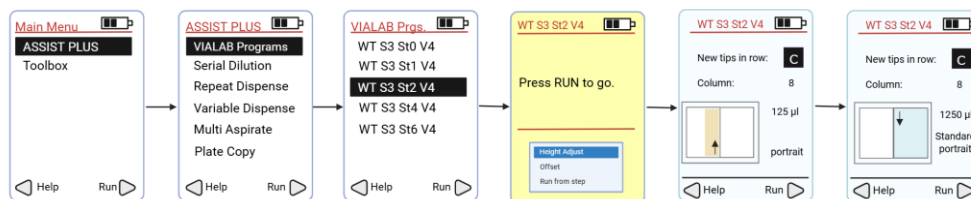

- Follow the program prompts for manual intervention:

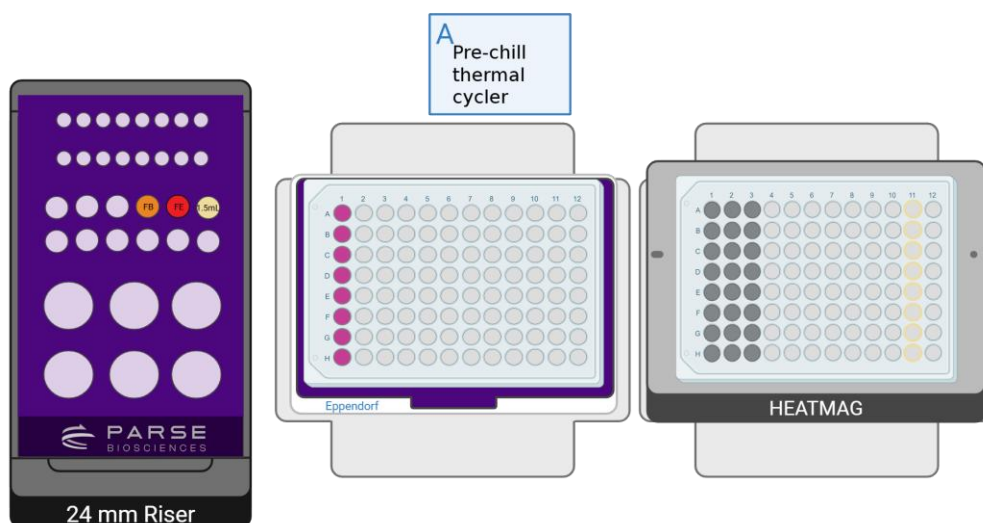

- a. Start the Fragmentation and End Prep program on the thermocycler to pre-chill, ensuring that Step 1 of the cycling program is set to 4°C, so it will be at the correct temperature when needed during Section 3.3.6. Press "Run" on the pipette to continue.

FRAGMENTATION AND END PREP		
Run Time	40 min	
Lid Temperature	70°C	
Sample Volume	50 µL	
Step	Time	Temperature
1	Hold	4°C
2	10 min	32°C
3	30 min	65°C
4	Hold	4°C

9. At the conclusion of the run:
 - a. Discard the tubes on Deck A.
 - b. Keep all labware on Decks B and C as they will be used in the next step.
 - c. Remove the Parse Metal Cold Block from the Deck A, place it on ice, and proceed immediately to Section 3.3.

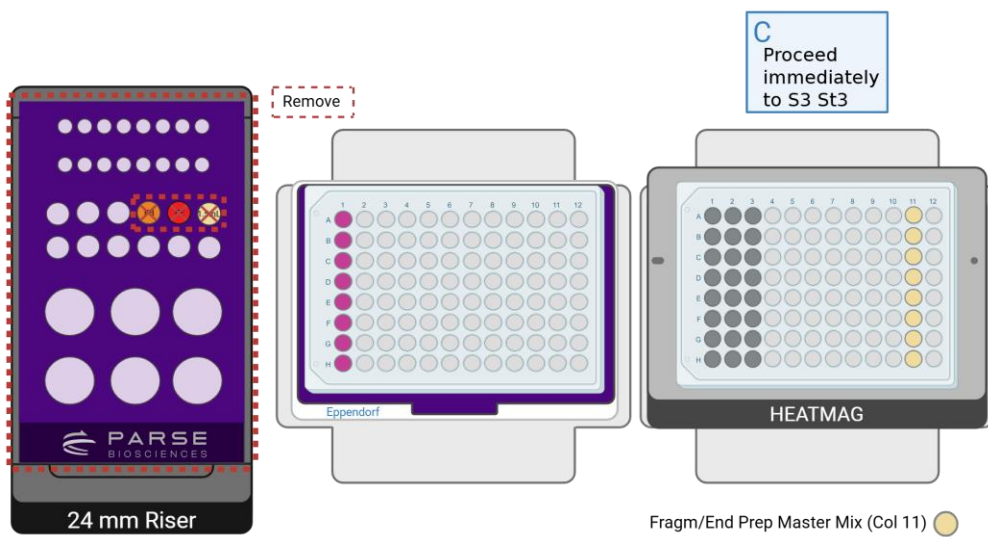

3.3. Fragmentation Mix Addition and Post-Fragmentation SPRI Cleanup

The program uses the VOYAGER multichannel pipette to add Fragmentation Mix to sublibraries. After the user runs the Fragmentation thermal cycling program, sublibraries are loaded back onto the ASSIST PLUS and a double-sided SPRI cleanup is carried out.

1. Gather the following components and reagents and set up the deck as indicated below:

ITEM	SOURCE	QTY	HANDLING AND STORAGE
VOYAGER Pipetting Module 8-Ch, 5-125 µL	INTEGRA Component	1	
Tip Deck for VOYAGER Pipetting Module	INTEGRA Component	1	
24 mm Labware Pedestal	INTEGRA Component	1	
Thermochromic PCR Cold Block	Parse	2	Pull the Thermochromic PCR Cold Block with riser from the -20°C freezer. Thaw one at room temperature for 10 minutes prior to use. Allow the second one to reach room temperature.
Thermochromic PCR Cold Block Riser	Parse	2	
HEATMAG with 96 Well Adapter	INTEGRA Component	1	
300 mL Reservoir Base	INTEGRA	1	
8 Row Reservoir Insert	INTEGRA	1	
125 µL Tip Rack	INTEGRA	1	
SealPlate	Consumables	as needed	
Ethanol	Reagents		Prepare 85% Ethanol by using 200 proof Ethanol and nuclease-free water. Make fresh the day it is needed.
Nuclease-free water	Reagents		



2. Prepare at least **5 mL** of 85% ethanol with nuclease-free water.
3. Place a clean 8 Row Reservoir Insert on the 300 mL Reservoir Base on the 24 mm Labware Pedestal on Deck A. The deck layout should correspond to the configuration below.

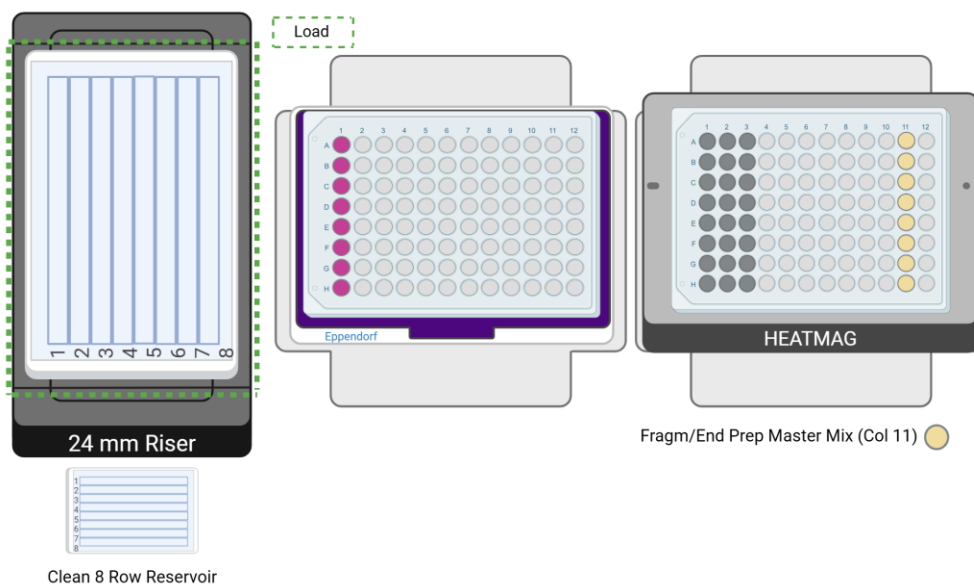

4. Change the pipette that is connected to the INTEGRA ASSIST PLUS:
 - a. Remove D-ONE Pipetting Module 1-Ch, 5-1250 μ L and corresponding Tip Deck. Ensure it is disconnected by pressing the back button until the main menu is displayed.
 - b. Replace it with VOYAGER 8-Ch 5-125 μ L Pipette and corresponding Tip Deck. Ensure the Tip Deck and tip box are securely positioned by pressing them down firmly until they click into place. Remove the tip box lid prior to starting the program.

5. Select and run the program **WT S3 St3 V4_0** following the diagram below.

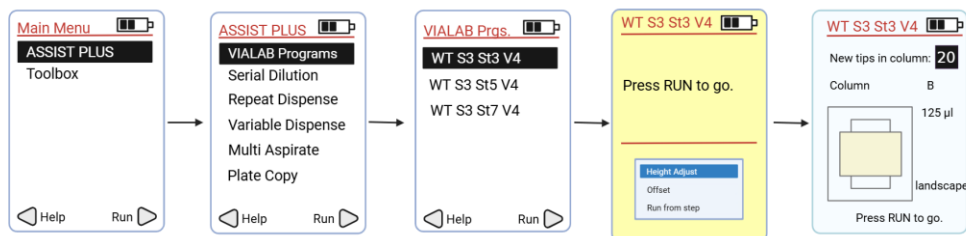

6. Press "Run" to continue the program. Follow the program prompts for manual intervention:

- a. Remove the **cDNA Sample** plate from Deck B and seal with a PCR plate seal. Place the sealed plate into the pre-cooled thermocycler from Section 3.2.8a.

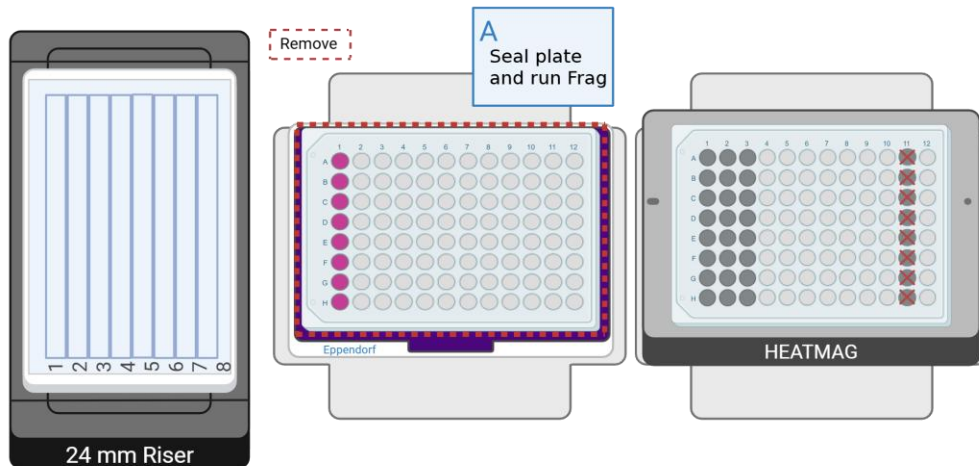

7. Ensure the thermocycler is cool prior to use and start the Fragmentation and End Prep program in the thermocycler pre-cooled in Section 3.2.8a. Skip the 4°C hold in Step 1 so the thermocycler proceeds to Step 2 of the Fragmentation and End Prep program.

8. While the thermocycler is running, press "Run" on the pipette to continue the program. Follow the program prompts for manual intervention:

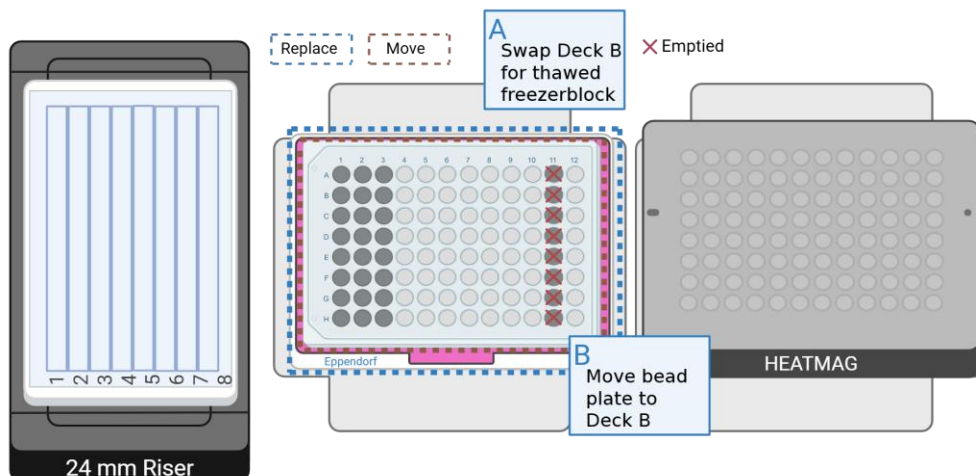

- a. Replace the frozen ThermoChromic PCR Cold Block with riser on Deck B with the one that has been brought to room temperature. A fully thawed ThermoChromic PCR Cold block should look pink in color. Press "Run" to continue.
- b. Move the **Reagent Plate S3** on Deck C onto the fully thawed ThermoChromic PCR Cold Block on Deck B with A1 in the upper left. Press "Run" on the pipette to continue.

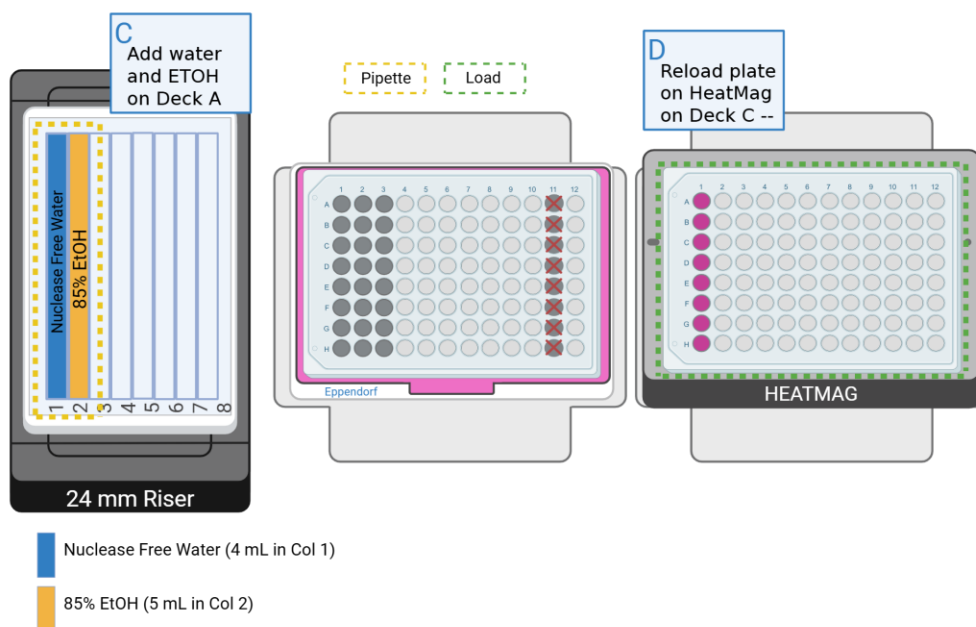

- c. With a P1000 pipette set to 1,000 μ L add:
 - i. **4 mL** nuclease free water in lane **1** of the 8 Row Reservoir on Deck A.

ii. **5 mL** 85% Ethanol in lane **2** of the 8 Row Reservoir on Deck A. Press "Run" to continue.



CRITICAL! Ensure the nuclease free water and 85% Ethanol are in the correct locations. Incorrect placement of these reagents will lead to an assay failure.

d. When Fragmentation has completed and when prompted, load the **cDNA Sample** plate onto the HEATMAG on Deck C with A1 in the upper left corner. Ensure the nuclease free water and the 85% Ethanol are evenly distributed within their rows. Press "Run" to continue.

9. At the conclusion of the run:

a. Cover with a plastic plate seal and remove the 8 Row Reservoir on Deck A. Store at room temperature for later use.

b. Keep all labware on Decks B and C. They will be used for the next step.

10. When the program is complete, continue to Section 3.4.

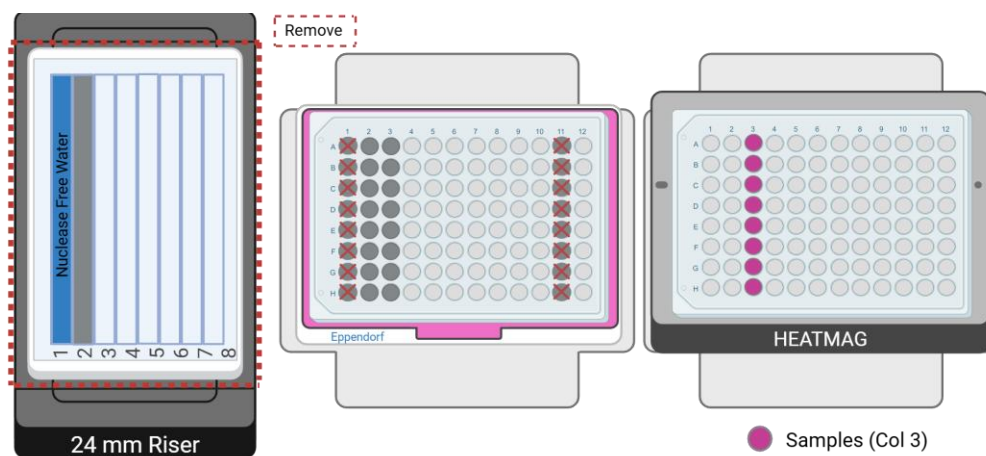

Safe stopping point: The size-selected fragmented and end prepped **cDNA Sample** plate can be stored at 4°C for up to 18 hours or at -20°C for up to 2 weeks. The **Reagent Plate S3** on Deck B can be sealed with a plastic plate seal and stored at room temperature.



3.4. Ligation Mix Creation and Plating

The program prepares the Ligation Mix in a clean 1.5 mL tube, then dispenses it into column 10 of the **Reagent Plate S3** on Deck B, allowing for easy pipetting into sublibraries using the multichannel pipette.

1. Gather the following components and reagents:

ITEM	SOURCE	QTY	HANDLING AND STORAGE
D-ONE Pipetting Module 1-Ch, 5-1250 μ L	INTEGRA Component	1	
Tip Deck for D-ONE Pipetting Module	INTEGRA Component	1	
Parse Metal Cold Block	Parse	1	
24 mm Labware Pedestal	INTEGRA Component	1	
Thermochromic PCR Cold Block	Parse	1	Ensure the Thermochromic PCR Cold Block with riser is at room temperature before use.
Thermochromic PCR Cold Block Riser	Parse	1	
HEATMAG with 96 Well Adapter	INTEGRA Component	1	
125 μ L Tip Rack	INTEGRA	1	
1250 μ L Tip Rack	INTEGRA	1	
1.5 mL tube	Consumables	2	
● Ligation Adapter	-20°C Reagents	1	Thaw at room temperature then place on ice. Mix by inverting 3x. Briefly centrifuge before use.
● Adapter Ligation Buffer	-20°C Reagents	1	
● Adapter Ligation Enzyme	-20°C Reagents	1	Place directly on ice. Briefly centrifuge before use.
Nuclease-free water	Reagents		

2. Place the Parse Metal Cold Block on Deck A. The deck layout should correspond to the configuration below.



3. On the Parse Metal Cold Block place these components following the deck configuration below:

- a. Column 2:
 - i. Pos 7: a clean 1.5 mL tube.
 - ii. Pos 8: ● Ligation Adapter.
 - iii. Pos 9: ● Adapter Ligation Enzyme.
 - iv. Pos 10: ● Adapter Ligation Buffer.
 - v. Pos 11: a 1.5 mL tube filled with **200 μ L** of nuclease free water.

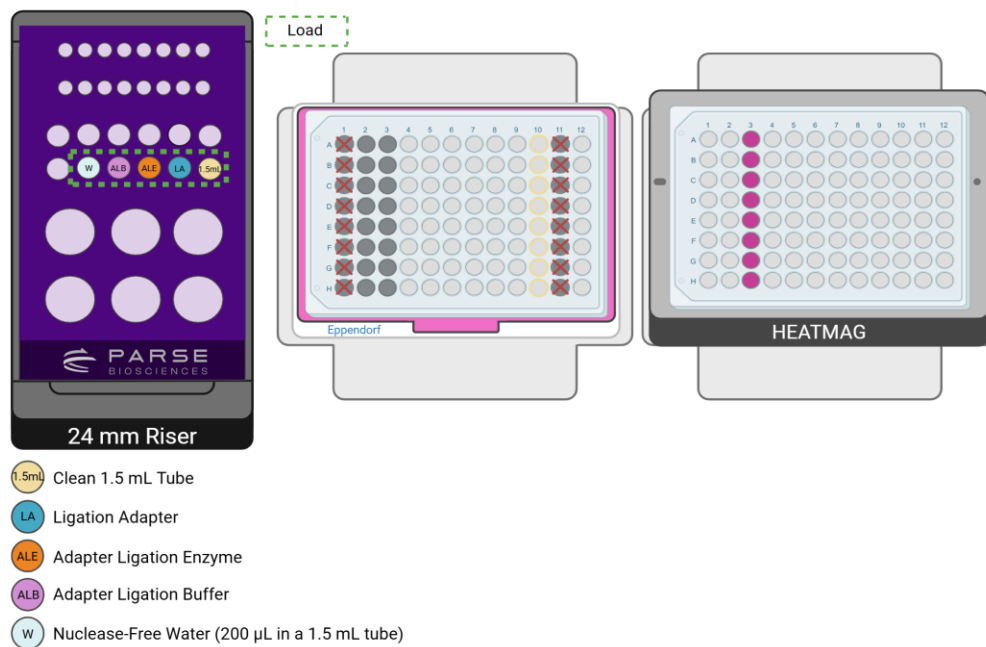

4. Change the pipette that is connected to the INTEGRA ASSIST PLUS:
 - a. Remove the VOYAGER 8-Ch 5-125 μ L Pipette and corresponding Tip Deck. Ensure it is disconnected by pressing the back button until the main menu is displayed.
 - b. Replace it with D-ONE Pipetting Module 1-Ch, 5-1250 μ L and corresponding Tip Deck. Ensure the tip deck and tip boxes are securely positioned by pressing them down firmly until they click into place. Remove the tip box lid prior to starting the program.

5. Remove the reagent caps, select and run the program **WT S3 St4 V4_0** following the diagram below.

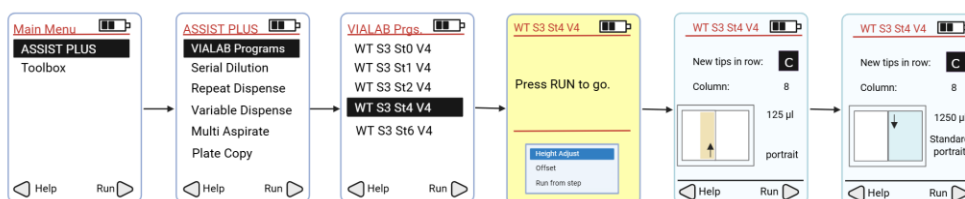

6. At the conclusion of the program:
 - a. Remove the Parse Metal Cold Block from Deck A. Discard all the tubes.
 - b. Keep all labware on Decks B and C. Proceed immediately to section 3.5.

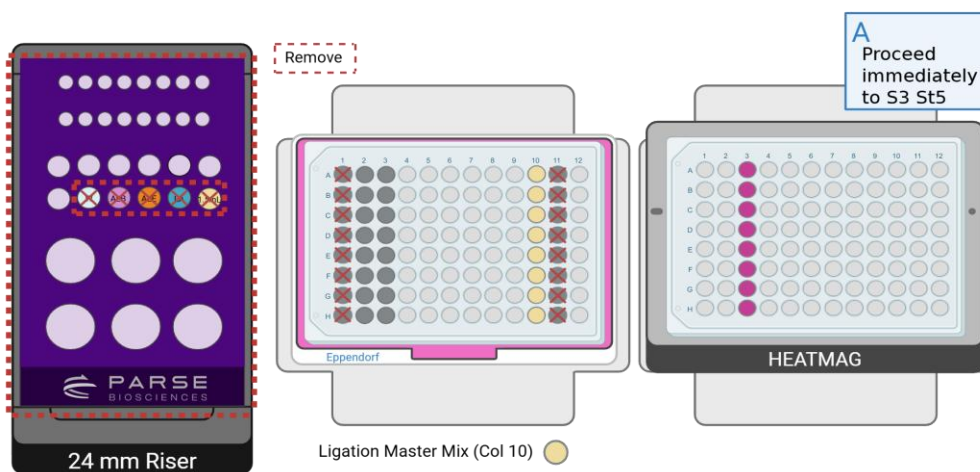

3.5. Ligation Master Mix Addition and Post-Ligation SPRI Cleanup

The program uses the VOYAGER multichannel pipette to add Ligation Mix to sublibraries. After the user runs the Ligation thermocycling program, sublibraries are loaded back onto the ASSIST PLUS and a single-sided SPRI cleanup is carried out.

1. Gather the following components and reagents:

ITEM	SOURCE	QTY	HANDLING AND STORAGE
VOYAGER Pipetting Module 8-Ch, 5-125 μ L	INTEGRA Component	1	
Tip Deck for VOYAGER Pipetting Module	INTEGRA Component	1	
24 mm Labware Pedestal	INTEGRA Component	1	
Thermochromic PCR Cold Block	Parse	1	Ensure the Thermochromic PCR Cold Block with riser is at room temperature before use.
Thermochromic PCR Cold Block Riser	Parse	1	
HEATMAG with 96 Well Adapter	INTEGRA Component	1	
300 mL Reservoir Base	INTEGRA Component	1	
125 μ L Tip Rack	INTEGRA	1	
SealPlate	Consumables	as needed	
Ethanol	Reagents		Prepare 85% Ethanol by using 200 proof Ethanol and nuclease-free water. Make fresh the day it is needed.
Nuclease-free water	Reagents		

2. Prepare at least **5 mL** of 85% ethanol with nuclease-free water.

3. Load the 8 mL Reservoir stored from Section 3.3 onto a 300 mL Reservoir Base and place on the 24 mm Labware Pedestal on Deck A. Remove the plastic plate seal. The deck layout should correspond to the configuration below.

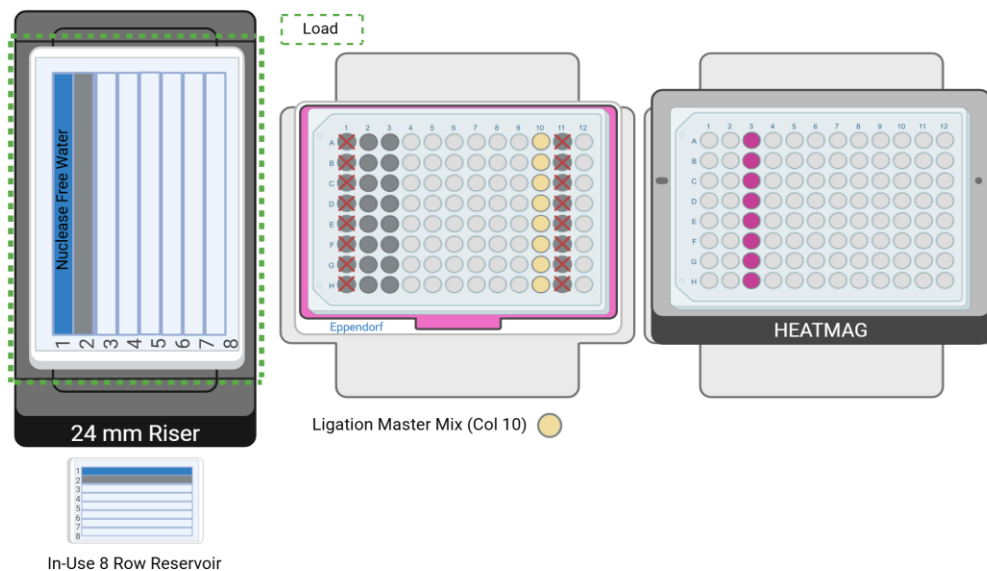

4. Change the pipette that is connected to the INTEGRA ASSIST PLUS:
 - a. Remove the D-ONE Pipetting Module 1-Ch, 5-1250 μ L and corresponding Tip Deck. Ensure it is disconnected by pressing the back button until the main menu is displayed.
 - b. Replace it with VOYAGER 8-Ch 5-125 μ L Pipette and corresponding Tip Deck. Ensure the tip deck and tip box are securely positioned by pressing them down firmly until they click into place. Remove the tip box lid prior to starting the program.

5. Navigate to the VIALAB programs on the Voyager Pipetting Module, select and run the program **WT S3 St5 V4_0** following the diagram below.

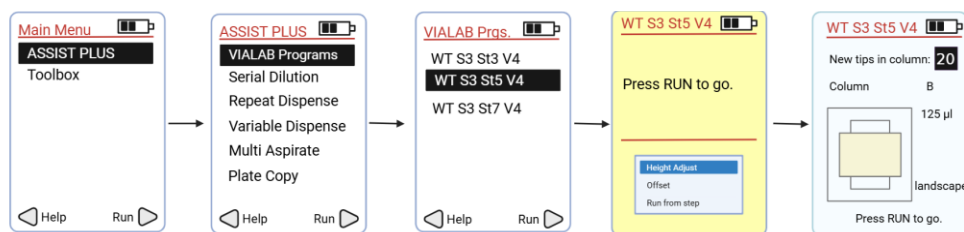

6. Press "Run" to continue the program. Follow the program prompts for manual intervention:

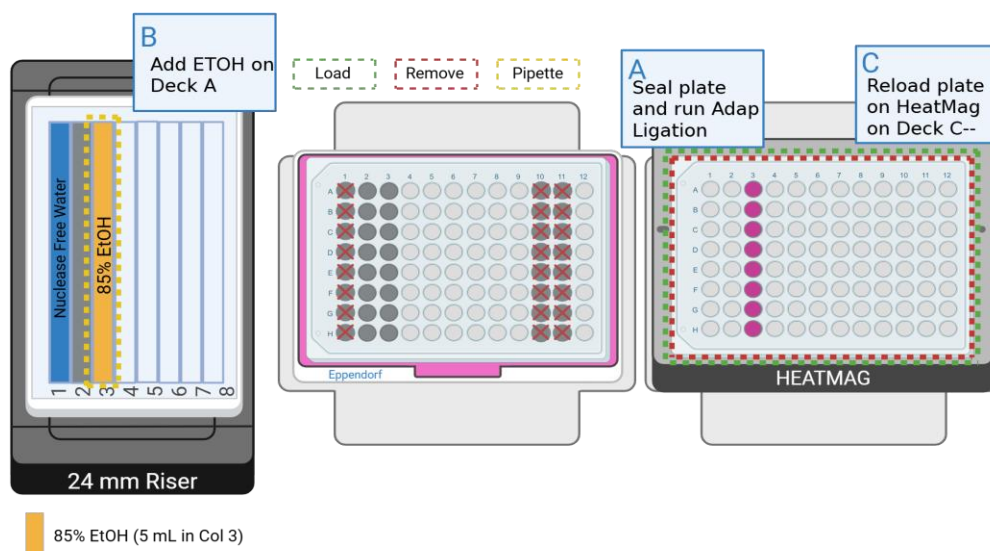

- a. Seal the **cdNA Sample** plate with a PCR plate seal on Deck C and place it into a thermocycler. Run the following program. Proceed to the next step while the program is still running.

ADAPTER LIGATION		
Run Time	15 minutes	
Lid Temperature	30°C*	
Sample Volume	100 µL	
Step	Time	Temperature
1	15 min	20°C
2	Hold	4°C



Note: *If the thermocycler's lid can't reach the recommended temperature of 30°C, turn the lid heating off.

- b. With a P1000 pipette set to 1000 μ L, add **5 mL** 85% Ethanol to lane **3** of the 8 Row Reservoir on Deck A.
 - c. Upon thermocycling completion reload the **cDNA Sample** plate onto the HEATMAG with 96 Well Adapter located on Deck C and remove the seal.
7. At the conclusion of the program:
- a. Remove the reagent reservoir on Deck A and cover with a plastic plate seal. Store at room temperature for later use.
 - b. Keep all labware on Decks B and C. Proceed to Section 3.6.

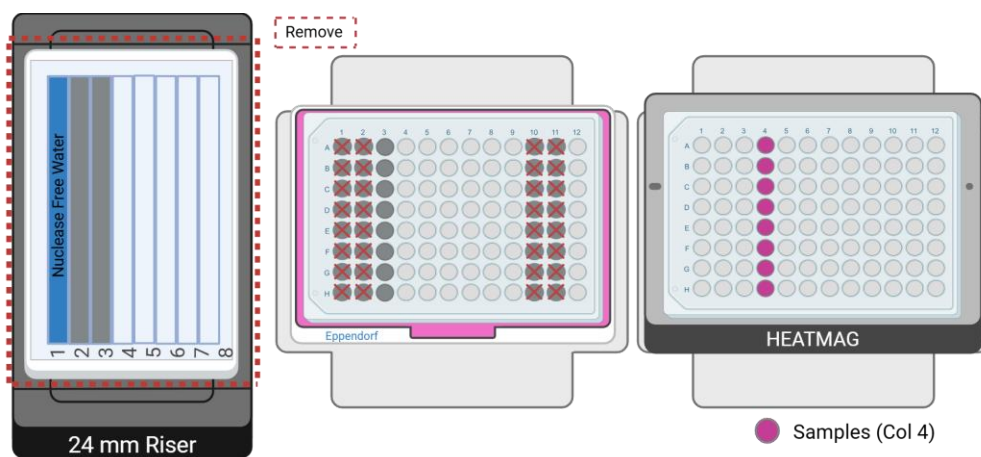

3.6. Barcoding Round 4

Program uses the pipette to aliquot out the Library Amp Mix such that it can be easily pipetted into sublibraries using the multichannel pipette. During this program, the user will manually add UDIs to sublibraries.

1. Gather the following components and reagents:

ITEM	SOURCE	QTY	HANDLING AND STORAGE
D-ONE Pipetting Module 1-Ch, 5-1250 μ L	INTEGRA Component	1	
Tip Deck for D-ONE Pipetting Module	INTEGRA Component	1	
Parse Metal Cold Block	INTEGRA Component	1	
24 mm Labware Pedestal	INTEGRA Component	1	
Thermochromic PCR Cold Block	Parse	1	Ensure the Thermochromic PCR Cold Block with riser is at room temperature before use.
Thermochromic PCR Cold Block Riser	Parse	1	
HEATMAG with 96 Well Adapter	INTEGRA Component	1	
125 μ L Tip Rack	INTEGRA	1	
1250 μ L Tip Rack	INTEGRA	1	
● Library Amp Mix	-20°C Reagents	1	Thaw at room temperature then place on ice. Mix by inverting 3x. Briefly centrifuge before use.
UDI Plate - WT	Parse reagents	1 sealed well per sublibrary	Thaw at room temperature then place on ice.

2. Load the Parse Metal Cold Block on the 24 mm Labware Pedestal on Deck A. The deck layout should correspond to the configuration below.

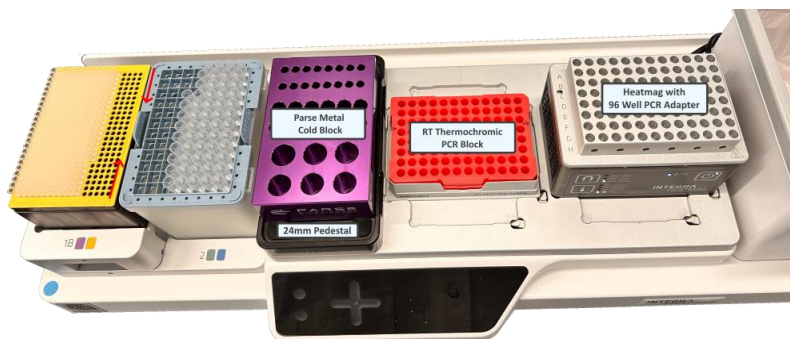

3. Place the ● Library Amp Mix in the Parse Metal Cold Block, column 1, position 4. The deck layout should correspond to the configuration below.

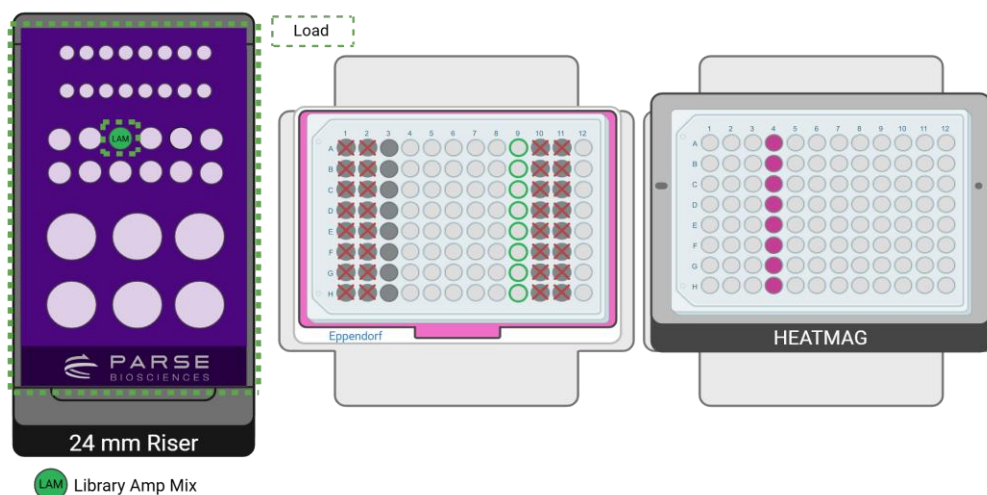

4. Change the pipette that is connected to the INTEGRA ASSIST PLUS:
 - a. Remove the VOYAGER 8-Ch 5-125 μ L Pipette and corresponding Tip Deck. Ensure it is disconnected by pressing the back button until the main menu is displayed.
 - b. Replace it with D-ONE Pipetting Module 1-Ch, 5-1250 μ L and corresponding Tip Deck. Ensure the tip deck and tip boxes are securely positioned by pressing them down firmly until they click into place. Remove the tip box lids prior to starting the program.

- Uncap the reagents caps, select and run the program **WT S3 St6 V4_0** following the diagram below.

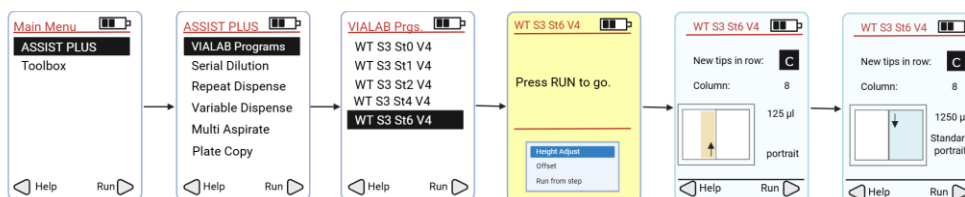

- While program is running, centrifuge the thawed UDI Plate - WT at 100 x g for **1 minute**.
- Wipe the surface of the UDI Plate - WT with 70% ethanol and allow it to dry.
- Orient the UDI Plate - WT with the notch on the bottom left as pictured below. For each sublibrary being processed, choose one unused well of the UDI Plate - WT and **record the well position and number for each sublibrary**.

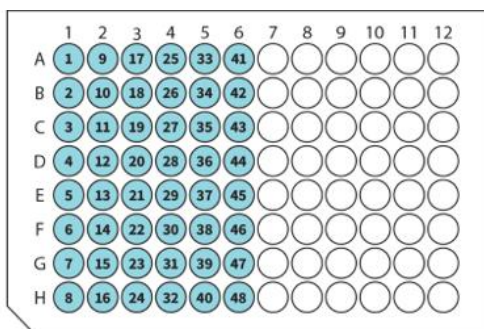

- With a multichannel P20, manually pierce the seal of the chosen wells of the UDI Plate - WT.
- When prompted**, with a multichannel P20 and new tips, manually mix by pipetting 5x then immediately transfer **4 µL** from a chosen unused well of the UDI Plate - WT to its corresponding sample well in column 4 on Deck C.



Note: Record which UDI wells were used for each sample well.



CRITICAL! Only transfer primers from 1 well of the UDI Plate - WT to 1 well of adapter ligated DNA.

- If any unused wells remain in the UDI Plate - WT, store the plate at -20°C. Do not reuse pierced wells.

12. Press "Run" to continue the program. At the conclusion of the run:

- a. Remove all labware from Deck A.
- b. Proceed immediately to Section 3.7.

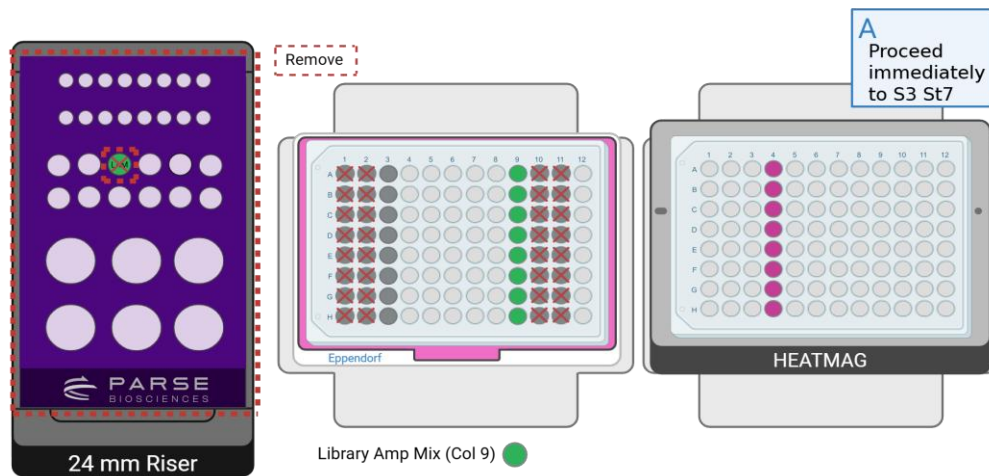

3.7. Library Amp Mix Addition and Size Selection

The program uses the VOYAGER multichannel pipette to add Library Amp Mix to the sublibraries. After the user runs the Indexing PCR thermocycling program, sublibraries are loaded back onto the ASSIST PLUS and a double-sided SPRI cleanup is carried out.

1. Gather the following components and reagents:

ITEM	SOURCE	QTY	HANDLING AND STORAGE
VOYAGER Pipetting Module 8-Ch 5-125 μ L	INTEGRA Component	1	
Tip Deck for VOYAGER Pipetting Module	INTEGRA Component	1	
24 mm Labware Pedestal	INTEGRA Component	1	
Thermochromic PCR Cold Block	Parse	1	Ensure the Thermochromic PCR Cold Block with riser is at room temperature before use.
Thermochromic PCR Cold Block Riser	Parse	1	
300 mL Reservoir Base	INTEGRA Component	1	
HEATMAG with 96 Well Adapter	INTEGRA Component	1	
125 μ L Tip Rack	INTEGRA	1	
SealPlate	Consumables	as needed	
Ethanol	Reagents		Prepare 85% Ethanol by using 200 proof Ethanol and nuclease-free water. Make fresh the day it is needed.
Nuclease-free water	Reagents		



2. Prepare **5 mL** of 85% ethanol with nuclease-free water.
3. Load the 8 mL Reservoir stored from Section 3.5 onto a 300 mL Reservoir Base and place on the 24 mm Labware Pedestal on Deck A. Remove the plastic plate seal. The deck layout should correspond to the configuration below.

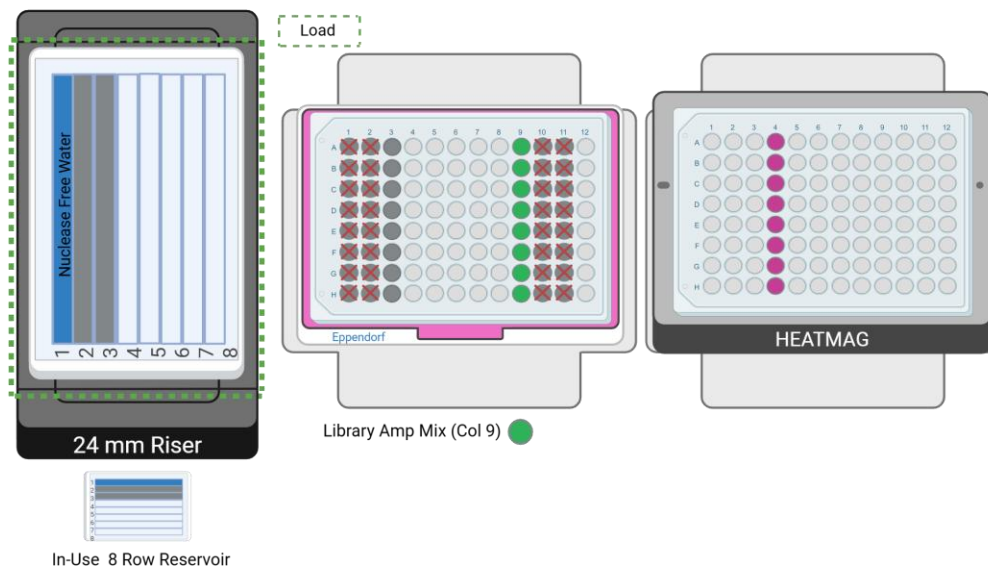

4. Change the pipette that is connected to the INTEGRA ASSIST PLUS:
 - a. Remove D-ONE Pipetting Module 1-Ch, 5-1250 μ L and corresponding Tip Deck. Ensure it is disconnected by pressing the back button until the main menu is displayed.
 - b. Replace it with VOYAGER 8-Ch 5-125 μ L Pipette and corresponding Tip Deck. Ensure the tip deck and tip box are securely positioned by pressing them down firmly until they click into place. Remove the tip box lid prior to starting the program.
5. Select and run the program **WT S3 St7 V4_0** following the diagram below.

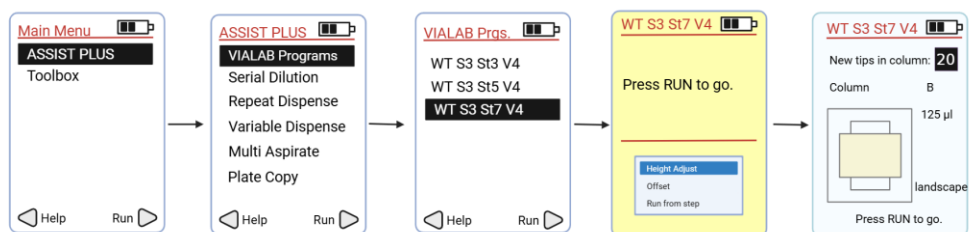

6. While the program is running, determine the number of PCR cycles required for the Indexing PCR based on the amount of cDNA added to the fragmentation and end prep reaction.

NUMBER OF PCR CYCLES	
cDNA Input (ng)	PCR Cycles
10-24	13
25-49	12
50-99	11
100-199	10
200-399	9
400-999	8
1,000 or more	7

7. Press "Run" to continue the program. Follow the program prompts for manual intervention:

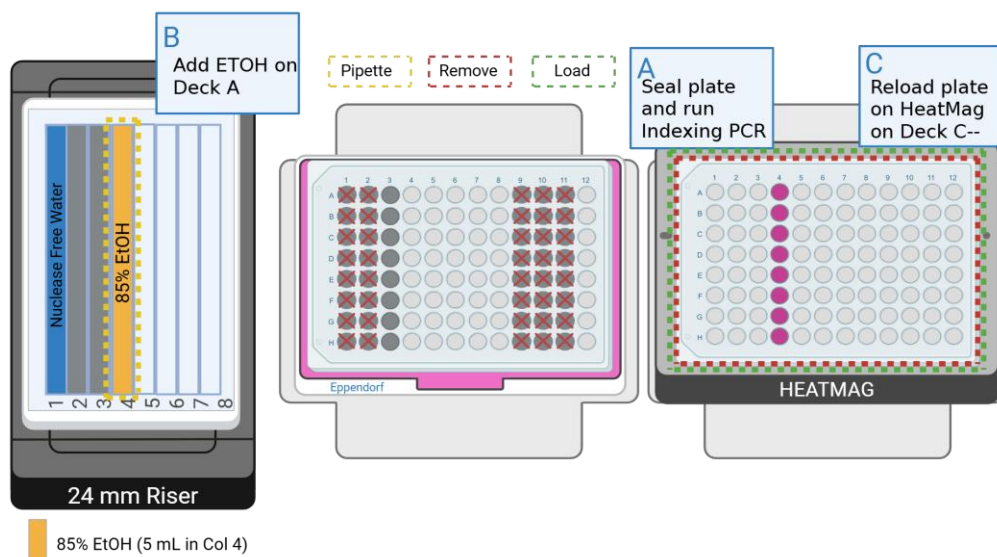

- a. Remove the **cDNA Sample** plate from the INTEGRA ASSIST PLUS, seal the sample plate on Deck C with a plastic plate seal and place it into a thermocycler. Run the following program. When the Indexing PCR thermocycling program is complete, press "Run" on the Assist Plus to continue.

INDEXING PCR			
Run Time	Lid Temperature	Sample Volume	
~30 min	105°C	50 µL	
Step	Time	Temperature	Cycles
1	3 min	95°C	1
2	20 s	98°C	Varies, see table above
3	20 s	67°C	
4	1 min	72°C	
5	5 min	72°C	1
6	Hold	4°C	1

- b. With a P1000 pipette, add **5 mL** 85% Ethanol to row **4** of the 8 Row Reservoir on Deck A. Press "Run" to continue.
- c. Reload the **cDNA Sample** plate onto the HEATMAG with 96 Well Adapter on Deck C.
8. At the conclusion of the run:
- a. The sequencing libraries will be in column 6 in the **cDNA Sample** plate on Deck C. Sequencing libraries can be stored at -20°C for up to 3 months. Seal the plate with a foil plate seal, then add a plastic plate seal on top of the foil plate seal. Alternatively, proceed directly to Section 3.8 to immediately quantify the Final Libraries. Seal the cDNA Sample plate after taking aliquots to QC.
- b. Discard the used 8 Row Reservoir on Deck A and their content.
- c. Discard the used **Reagent Plate S3** on Deck B.



Safe stopping point: the **cDNA Sample** plate can be stored at -20°C for up to 3 months.

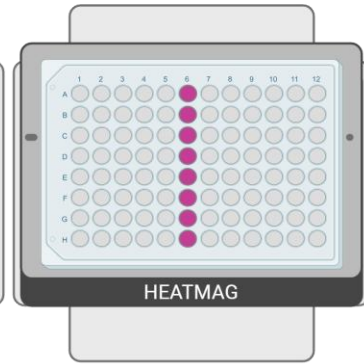
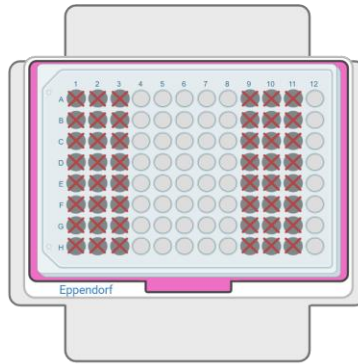
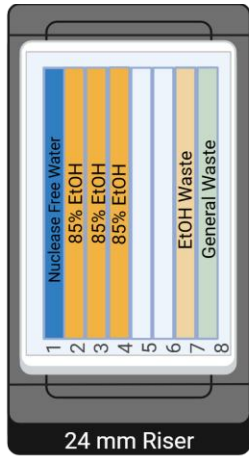

● Samples (Col 6)

3.8. Sequencing Library Quantification

The concentration and size distribution of the sequencing libraries are measured with fluorescent dyes and capillary electrophoresis. Sequencing libraries can be stored at -20°C for up to 3 months.

To quantify the sequencing libraries:

1. Measure the concentration of each purified sequencing library from Section 3.7 with the Qubit dsDNA HS (High Sensitivity) Assay Kit according to the manufacturer's instructions.
2. Assess the size distribution of each purified sequencing library with a High Sensitivity DNA Kit on the Agilent Bioanalyzer System or High Sensitivity D5000 or D1000 ScreenTape and Reagents on the Agilent TapeStation System according to the manufacturer's instructions.

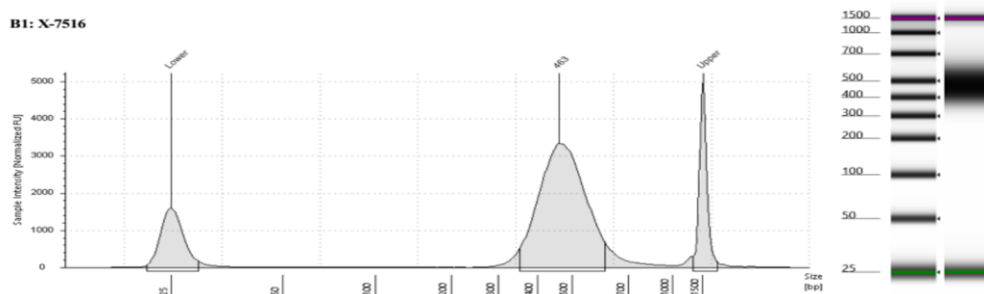

Figure 12: Expected Size Distribution before Illumina Sequencing. Example trace of Human DNA from indexed sublibraries run on a TapeStation.

Note: Samples may need to be diluted to be within the manufacturer's recommended concentration range. Typically, between a 1:3 to 1:10 dilution is appropriate.

Note: The traces above are representative of typical TapeStation of DNA from indexed sublibraries. There should be a peak between 300-450 bp. The prominence of the trace is dependent on the amount of DNA loaded into the TapeStation. Sublibraries with minor deviations can still produce high quality data.

Note: If using a Bioanalyzer, there may be an additional peak present. This typically occurs if products are overamplified, but it should not impact sequencing or data quality (assuming there is still a peak present at 300-450 bp). Do not use this additional peak when estimating amplicon size.



Appendices

Appendix A Sublibrary Gen Table

The Sublibrary Generation Table provides guidance for sample dilution in Section 1.3 to achieve a target sublibrary concentration.

Green text (top): Volume of cell suspension in μL (from step 1.3.27d) to add to each sublibrary.

Purple text (bottom): Volume of Pre-Lysis Dilution Buffer in μL to add to each sublibrary.

Blue Shading: Serial dilution of cell stock is required to improve sublibrary cell count.

Red Shading: Insufficient cell stock concentration for target sublibrary cell count.

Stock Conc. (cells/ μL)	Target Sublibrary Cell Count (cells/sublibrary)														
	200	500	1,000	2,000	3,000	4,000	5,000	6,000	7,000	8,000	9,000	10,000	11,000	12,000	12,500
50	4	10	20												
	21	15	5												
100	2	5	10	20											
	23	20	15	5											
200		2.5	5	10	15	20	25								
			20	15	10	5	0								
300			3.33	6.67	10	13.33	16.67	20	23.33	N/A					
			21.67	18.33	15	11.67	8.33	5	1.67	N/A					
400			2.5	5	7.5	10	12.5	15	17.5	20	22.5	25			
			22.5	20	17.5	15	12.5	10	7.5	5	2.5	0			
500			2	4	6	8	10	12	14	16	18	20	22	24	25
			23	21	19	17	15	13	11	9	7	5	3	1	0
600				3.33	5	6.67	8.33	10	11.67	13.33	15	16.67	18.33	20	20.83
				21.67	20	18.33	16.67	15	13.33	11.67	10	8.33	6.67	5	4.17
700				2.96	4.29	5.71	7.14	8.57	10	11.43	12.86	14.29	15.71	17.14	17.86
				22.14	20.71	19.29	17.86	16.43	15	13.57	12.14	10.71	9.29	7.86	7.14
800				2.5	3.75	5	6.25	7.5	8.75	10	11.25	12.5	13.75	15	15.63
				22.5	21.25	20	18.75	17.5	16.25	15	13.75	12.5	11.25	10	9.37
900				2.22	3.33	4.44	5.56	6.67	7.78	8.89	10	11.11	12.22	13.33	13.89
				22.78	21.67	20.56	19.44	18.33	17.22	16.11	15	13.89	12.78	11.67	11.11
1,000				2	3	4	5	6	7	8	9	10	11	12	12.5
				23	22	21	20	19	18	17	16	15	14	13	12.5
1,100					2.73	3.64	4.55	5.45	6.36	7.27	8.18	9.09	10	10.91	11.36
					22.27	21.36	20.45	19.55	18.64	17.73	16.82	15.91	15	14.09	13.64
1,200					2.5	3.33	4.17	5	5.83	6.67	7.5	8.33	9.17	10	10.42
					22.5	21.67	20.83	20	19.17	18.33	17.5	16.67	15.83	15	14.58
1,300					2.31	3.08	3.85	4.62	5.38	6.15	6.92	7.69	8.46	9.23	9.62
					22.69	21.92	21.15	20.38	19.62	18.85	18.08	17.31	16.54	15.77	15.38
1,400					2.14	2.86	3.57	4.29	5	5.71	6.43	7.14	7.86	8.57	8.93
					22.86	22.14	21.43	20.71	20	19.29	18.57	17.86	17.14	16.43	16.07
1,500					2	2.67	3.33	4	4.67	5.33	6	6.67	7.33	8	8.33
					23	22.33	21.67	21	20.33	19.67	19	18.33	17.67	17	16.67
1,600					2.5	3.13	3.75	4.38	5	5.63	6.25	6.88	7.5	7.81	
					22.5	21.87	21.25	20.62	20	19.37	18.75	18.12	17.5	17.19	
1,700					2.35	2.94	3.53	4.12	4.71	5.29	5.88	6.47	7.06	7.35	
					22.65	22.06	21.47	20.88	20.29	19.71	19.12	18.53	17.94	17.65	
1,800					2.22	2.78	3.33	3.89	4.44	5	5.56	6.11	6.67	6.94	
					22.78	22.22	21.67	21.11	20.56	20	19.44	18.89	18.33	18.06	
1,900					2.11	2.63	3.16	3.68	4.21	4.74	5.26	5.79	6.32	6.58	
					22.89	22.37	21.84	21.32	20.79	20.26	19.74	19.21	18.68	18.42	
2,000					2	2.5	3	3.5	4	4.5	5	5.5	6	6.25	
					23	22.5	22	21.5	21	20.5	20	19.5	19	18.75	
2,100						2.38	2.86	3.33	3.81	4.29	4.76	5.24	5.71	5.95	
						22.62	22.14	21.67	21.19	20.71	20.24	19.76	19.29	19.05	
2,200						2.27	2.73	3.18	3.64	4.09	4.55	5	5.45	5.68	
						22.73	22.27	21.82	21.36	20.91	20.45	20	19.55	19.32	
2,300						2.17	2.61	3.04	3.48	3.91	4.35	4.78	5.22	5.43	
						22.83	22.39	21.96	21.52	21.09	20.65	20.22	19.78	19.57	

Appendix B: Sequencing Information

We recommend a minimum sequencing depth of 10,000 reads per cell for whole transcriptome libraries. However, ideal sequencing depth is dependent on the sample type and experimental goals. For example, if trying to capture rare cell types in a heterogenous population, deeper sequencing is required. Alternatively, analyzing a homogenous population, more shallow sequencing may be appropriate.

Whole transcriptome sequencing libraries should be diluted and denatured according to the manufacturer's instructions for the relevant sequencing instrument. If using the Illumina platform, we strongly recommend adding 5% PhiX for optimal sequencing quality.

Details of the final whole transcriptome sequencing library structure are below.

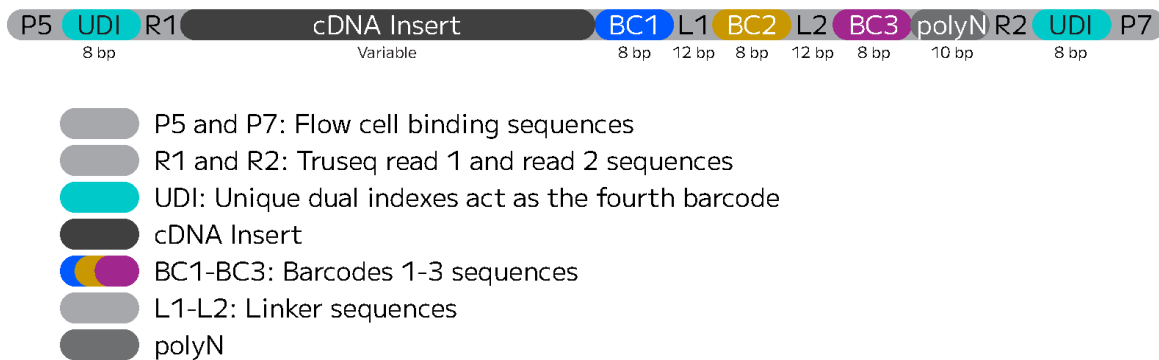

Figure 13: Whole transcriptome sequencing library structure.

Libraries should be sequenced with paired reads using the read structure in the table below. Read lengths longer than those recommended below are acceptable, but additional bases in read 2 are trimmed by the Parse Analysis Pipeline.

READ	FUNCTION	INSERT
Read 1	cDNA Insert	64
i7 Index (Index 1)	Barcode 4 / UDI	8
i5 Index (Index 2)	Barcode 4 / UDI	8
Read 2	Barcodes 1-3	58

The fourth barcode that tags each sublibrary acts as a standard Illumina i7 and i5 indexes. Please refer to the following table to demultiplex the whole transcriptome libraries.

Sublibrary Index ID	Well Position	i7 Forward Sequence	i5 Reverse Complement Sequence	i5 Forward Sequence
UDI_Plate_WT_1	A1	CAGATCAC	ATGTGAAG	CTTCACAT
UDI_Plate_WT_2	B1	ACTGATAG	GTCCAACC	GGTTGGAC
UDI_Plate_WT_3	C1	GATCAGTC	AGAGTCAA	TTGACTCT
UDI_Plate_WT_4	D1	CTTGTAAT	AGTTGGCT	AGCCAAC T
UDI_Plate_WT_5	E1	AGTCAAGA	ATAAGGCG	CGCCTTAT
UDI_Plate_WT_6	F1	CCGTCCTA	CCGTACAG	CTGTACGG
UDI_Plate_WT_7	G1	GTAGAGTA	CATTCATG	CATGAATG
UDI_Plate_WT_8	H1	GTCCGCCT	AGATACGG	CCGTATCT
UDI_Plate_WT_9	A2	GTGAAACT	TACAGACT	AGTCTGTA
UDI_Plate_WT_10	B2	TCATTCCT	AATGCCTG	CAGGCATT
UDI_Plate_WT_11	C2	GGTAGCAT	TGCTTGCC	GGCAAGCA
UDI_Plate_WT_12	D2	ACTTGATC	TTTGGGTG	CACCCAAA
UDI_Plate_WT_13	E2	ATGAGCAT	GAATCTGA	TCAGATTC
UDI_Plate_WT_14	F2	GCGCTATC	CGACTGGA	TCCAGTCG
UDI_Plate_WT_15	G2	TGACCAGT	ACATTGGC	GCCAATGT
UDI_Plate_WT_16	H2	TATAATCA	ACCACTGT	ACAGTGGT
UDI_Plate_WT_17	A3	CAAAGTC	CGGTTGTT	AACAACCG
UDI_Plate_WT_18	B3	CGATGTCA	CATGAGGA	TCCTCATG
UDI_Plate_WT_19	C3	CTCAGAGT	TGGAGAGT	ACTCTCCA
UDI_Plate_WT_20	D3	TAATCGAC	TGACTTCG	CGAAGTCA
UDI_Plate_WT_21	E3	CATTTTCT	GGAAGGAT	ATCCTTCC
UDI_Plate_WT_22	F3	CTATACTC	TGTTTCGAG	CTCGAACA
UDI_Plate_WT_23	G3	CACTCACA	AAGGCTGA	TCAGCCTT
UDI_Plate_WT_24	H3	CTCGAACA	CTCGAGTG	CACTCGAG
UDI_Plate_WT_25	A4	CTCTATCG	ATCGGTGG	CCACCGAT

Sublibrary Index ID	Well Position	i7 Forward Sequence	i5 Reverse Complement Sequence	i5 Forward Sequence
UDI_Plate_WT_26	B4	TCCTCATG	AGGTCTTG	CAAGACCT
UDI_Plate_WT_27	C4	AACAACCG	AGGAAGCG	CGCTTCCT
UDI_Plate_WT_28	D4	GCCAATGT	ACATGTGT	ACACATGT
UDI_Plate_WT_29	E4	TGGTTGTT	ATACAGTT	AACTGTAT
UDI_Plate_WT_30	F4	TCTGCTGT	ATCGCCTT	AAGGCGAT
UDI_Plate_WT_31	G4	TTGGAGGT	TTCGACGC	GCGTCGAA
UDI_Plate_WT_32	H4	TCGAGCGT	TGTCGTTC	GAACGACA
UDI_Plate_WT_33	A5	TGCGATCT	TCCATAGC	GCTATGGA
UDI_Plate_WT_34	B5	TTCCTGCT	TAAGTGTC	GACACTTA
UDI_Plate_WT_35	C5	TTCCATTG	CTGGCATA	TATGCCAG
UDI_Plate_WT_36	D5	TAACGCTG	CTGAGCCA	TGGCTCAG
UDI_Plate_WT_37	E5	TTGGTATG	CTCAATGA	TCATTGAG
UDI_Plate_WT_38	F5	TGAACTGG	CGCATACA	TGTATGCG
UDI_Plate_WT_39	G5	TCCAGTCG	CCGAAGTA	TACTTCGG
UDI_Plate_WT_40	H5	TGTATGCG	CCAGTTCA	TGAACTGG
UDI_Plate_WT_41	A6	TGGCTCAG	CAGCGTTA	TAACGCTG
UDI_Plate_WT_42	B6	TATGCCAG	CAATGGAA	TTCCATTG
UDI_Plate_WT_43	C6	GGTTGGAC	ATCCTGTA	TACAGGAT
UDI_Plate_WT_44	D6	GACACTTA	AGCAGGAA	TTCCTGCT
UDI_Plate_WT_45	E6	GAACGACA	ACGCTCGA	TCGAGCGT
UDI_Plate_WT_46	F6	AAGGCGAT	ACAGCAGA	TCTGCTGT
UDI_Plate_WT_47	G6	ATGCTTGA	ACAAGCTA	TAGCTTGT
UDI_Plate_WT_48	H6	AGTATCTG	CATCAAGT	ACTTGATG

Appendix C: Pipetting Programs

Section 1.1. Sample Normalization

WT S1 St1 V4_0 DONE

STEPS	ACTION	DURATION
1	Initial Volumes	0
2	CombinedWTWorksheet	40 min 0 sec
3	Thaw R1 plate	0

Section 1.2. Reagents Preparation

WT S1 St2 V4_0 DONE

STEPS	ACTION	DURATION
1	Initial Volumes	0
2	Prompt to add Barcoding Buffer	0
3	Prompt to add Ligation Buffer	0
4	Aliquot R1 Stop (900 μ L/well x 2)	0 min 40 sec
5	Aliquot R2 Stop (1100 μ L/well)	0 min 30 sec
6	Aliquot Final stop Buffer (1000 μ L/well x 2)	0 min 41 sec
7	Aliquot Prelysis Wash Buffer (1100 μ L/well x 4)	1 min 9 sec
8	Add Ligation Enz to Ligation Buffer (44 μ L/well)	0 min 38 sec
9	Mix Ligation MM	0 min 35 sec
10	Mix Ligation MM	0 min 35 sec

STEPS	ACTION	DURATION
11	Mix Ligation MM	0 min 35 sec
12	Add Lysis Soln to MM (330 µL/well)	0 min 31 sec
13	Add Lysis Enzy to MM (66 µL/well)	0 min 41 sec
14	Mix Lysis MM	0 min 18 sec
15	Aliquot Lysis MM (35 µL/well)	1 min 59 sec
16	Volume Change	0

Section 1.3. Round 1, Round 2, Round 3 Plate Loading and Pooling

WT S1 St3 V4_0 VIAFLO_300

STEPS	ACTION	DURATION
1	Initial Volumes	0
2	Load the R1 Plate (15 µL/well)	2 min 13 sec
3	Prompt to start RT	0
4	Prompt to remove labware from Deck B	0
5	Prompt to load reservoir 1	0
6	Labware Change	0
7	Prompt to load R1 plate post RT	0
8	Prompt to thaw R2 Plate	0
9	Add R1 Stop to R1 plate (10 µL/well)	0 min 25 sec
10	R1 Plate 1st Pass Pool (50 µL/well)	1 min 28 sec
11	R1 Plate 2nd Pass Pool (10 µL/well)	0 min 27 sec

STEPS	ACTION	DURATION
12	Pipette 192 μ L CCMM in Row 1 on Deck C--	0
13	DELAY	5 min 0 sec
14	Bind beads	0 min 10 sec
15	DELAY	0 min 15 sec
16	Remove beads from pipetting locations	1 min 17 sec
17	Bead Binding Incubation	4 min 0 sec
18	Remove beads from pipetting area. No offset	1 min 27 sec
19	Remove excess vol from tip	1 min 27 sec
20	Bead Binding Incubation	10 min 0 sec
21	Remove soup 1 (150 μ L/well)	2 min 26 sec
22	Remove Soup 2 (300 μ L/well)	0 min 33 sec
23	Remove Soup 3 (50 μ L/well)	0 min 33 sec
24	Add Binding Buffer 1 (208 μ L/well)	2 min 24 sec
25	Remove soup 1 (175 μ L/well)	0 min 33 sec
26	Remove Soup 2 (100 μ L/well)	0 min 33 sec
27	Remove Soup 3 (100 μ L/well)	0 min 33 sec
28	Add Binding Buffer 2 (208 μ L/well)	2 min 24 sec
29	Remove soup 1 (175 μ L/well)	0 min 33 sec
30	Remove Soup 2 (100 μ L/well)	0 min 33 sec
31	Remove Soup 3 (100 μ L/well)	0 min 33 sec

STEPS	ACTION	DURATION
32	Release Magnet	0 min 10 sec
33	Add Ligation Mix (174 μ L/well x 2)	0 min 43 sec
34	Volume Change	0
35	Mix Middle	0 min 36 sec
36	Mix Odd	0 min 36 sec
37	Mix Even	0 min 36 sec
38	Reminder to remove strainer film	0
39	Prompt to load strainer	0
40	Prompt to Load R2 Plate	0
41	Volume Change	0
42	Strain Cells- center (300 μ L/well)	0 min 43 sec
43	Strain Cells (100 μ L/well)	0 min 32 sec
44	Prompt to remove strainer	0
45	Row 1: Load Plate - Even (40 μ L/well)	0 min 38 sec
46	Row 2: Load Plate - Odd (40 μ L/well)	0 min 37 sec
47	Row 3: Load Plate - Even (40 μ L/well)	0 min 37 sec
48	Row 4: Load Plate - Odd (40 μ L/well)	0 min 36 sec
49	Row 5: Load Plate - Even (40 μ L/well)	0 min 36 sec
50	Row 6: Load Plate - Odd (40 μ L/well)	0 min 35 sec
51	Row 7: Load Plate - Even (40 μ L/well)	0 min 34 sec

STEPS	ACTION	DURATION
52	Row 8: Load Plate - Odd (40 µL/well)	0 min 36 sec
53	Prompt for R2 incubation	0
54	Prompt to thaw R3	0
55	Prompt to load R2 post incubation	0
56	R2 Plate 1st Pass Pool (50 µL/well)	2 min 45 sec
57	R2 Plate 2nd Pass Pool (20 µL/well)	0 min 43 sec
58	Manual intervention to mix Post R2 Pool	0
59	Bind beads	0 min 10 sec
60	DELAY	0 min 15 sec
61	Remove beads from pipette tip	1 min 17 sec
62	Bead Binding Incubation	2 min 0 sec
63	Remove beads from pipetting locations	1 min 27 sec
64	Remove excess volume from tip	1 min 31 sec
65	Bead Binding Incubation	6 min 0 sec
66	Remove soup 1 (300 µL/well)	0 min 33 sec
67	Remove Soup 2 (150 µL/well)	0 min 33 sec
68	Remove Soup 3 (100 µL/well)	0 min 33 sec
69	Add Binding Buffer 1 (208 µL/well)	2 min 24 sec
70	Remove soup 1 (100 µL/well)	0 min 33 sec
71	Remove Soup 2 (100 µL/well)	0 min 33 sec

STEPS	ACTION	DURATION
72	Remove Soup 3 (100 µL/well)	0 min 33 sec
73	Add Binding Buffer 2 (208 µL/well)	2 min 24 sec
74	Remove soup 1 (100 µL/well)	0 min 33 sec
75	Remove Soup 2 (100 µL/well)	0 min 33 sec
76	Remove Soup 3 (100 µL/well)	0 min 33 sec
77	Release Magnet	0 min 10 sec
78	Add Ligation Mix (175 µL/well x 2)	0 min 31 sec
79	Volume Change	0
80	Mix Middle	0 min 36 sec
81	Mix Odd	0 min 36 sec
82	Mix Even	0 min 36 sec
83	Prompt to load R3 Plate	0
84	Prompt to load strainer	0
85	Volume Change	0
86	Strain Cells- Center (300 µL/well)	0 min 43 sec
87	Strain Cells (100 µL/well)	0 min 49 sec
88	Prompt to move strainer	0
89	Row 1: Load Plate - Even (43 µL/well)	0 min 38 sec
90	Row 2: Load Plate - Odd (43 µL/well)	0 min 37 sec
91	Row 3: Load Plate - Even (43 µL/well)	0 min 37 sec

STEPS	ACTION	DURATION
92	Row 4: Load Plate - Odd (43 μ L/well)	0 min 36 sec
93	Row 5: Load Plate - Even (43 μ L/well)	0 min 36 sec
94	Row 6: Load Plate - Odd (43 μ L/well)	0 min 35 sec
95	Row 7: Load Plate - Even (43 μ L/well)	0 min 34 sec
96	Row 8: Load Plate - Odd (43 μ L/well)	0 min 36 sec
97	Prompt for R3 incubation	0
98	Prompt to load R3 post incubation	0
99	R3 Plate 1st Pass Pool (50 μ L/well)	2 min 45 sec
100	R3 Plate 2nd Pass Pool (20 μ L/well)	0 min 43 sec
101	Strain Cells (300 μ L/well)	0 min 44 sec
102	Strain Cells (300 μ L/well)	0 min 37 sec
103	Prompt to remove strainer	0
104	Volume Change	0
105	Bind beads	0 min 10 sec
106	DELAY	0 min 15 sec
107	Remove beads from pipetting locations	1 min 17 sec
108	Bead Binding Incubation	2 min 0 sec
109	Remove excess liquid from tip	1 min 38 sec
110	Remove excess liquid from tip	1 min 31 sec
111	Bead Binding Incubation	6 min 0 sec

STEPS	ACTION	DURATION
112	Remove soup 1 (300 µL/well)	0 min 33 sec
113	Remove Soup 2 (100 µL/well)	0 min 33 sec
114	Remove Soup 3 (100 µL/well)	0 min 33 sec
115	Add Pelyse Wash Buffer (166.5 µL/well x 2)	0 min 31 sec
116	Release Magnet	0 min 10 sec
117	Mix Middle	0 min 45 sec
118	Mix Odd	0 min 45 sec
119	Mix Even	0 min 45 sec
120	Bind beads	0 min 10 sec
121	DELAY	0 min 30 sec
122	Remove beads from pipetting locations	1 min 24 sec
123	Bead Binding Incubation	2 min 0 sec
124	Remove excess liquid from tip	1 min 38 sec
125	Remove excess liquid from tip	1 min 31 sec
126	Bead Binding Incubation	7 min 0 sec
127	Remove soup 1 (300 µL/well)	0 min 33 sec
128	Remove Soup 2 (100 µL/well)	0 min 33 sec
129	Remove Soup 3 (100 µL/well)	0 min 33 sec
130	Prompt to pool samples	0
131	Prompt to count cells	0

Section 1.4. Lysate Creation

WT S1 St4 V4_0 VOYAGER_125

STEPS	ACTION	DURATION
1	Initial Volumes	0
2	Prompt to load lysates	0
3	Prompt to load Lysis MM	0
4	Add Lysis MM to Lysates (30 μ L/well)	0 min 40 sec
5	Prompt to vortex samples	0
6	Prompt to load samples post lysis incubation	0
7	DELAY	2 min 0 sec
8	Remove beads from Lysates (70 μ L/well)	0 min 50 sec
9	Prompt to seal and store lysates	0

Section 2.1. Streptavidin Beads and Buffer Preparation

WT S2 St1 V4_0 DONE

STEPS	ACTION	DURATION
1	Initial Volumes	0
2	Strep Beads (44 μ L/well)	1 min 51 sec
3	Binding Buffer (58 μ L/well)	0 min 57 sec
4	Bead Wash Col 9 (200 μ L/well)	1 min 8 sec
5	Wash A (1000 μ L/well x 3)	0 min 54 sec

STEPS	ACTION	DURATION
6	Wash B (1000 μ L/well x 3)	0 min 54 sec
7	Proceed to next step	0

Section 2.2. cDNA Capture

WT S2 St2 V4_0 VOYAGER

STEPS	ACTION	DURATION
1	Initial Volumes	0
2	Thaw Lysates	0
3	Raise Magnet	0 min 10 sec
4	DELAY	2 min 0 sec
5	Remove Supernatant 1 (60 μ L/well)	0 min 36 sec
6	Release Magnet	0 min 10 sec
7	Bead Wash 1x (60 μ L/well)	1 min 12 sec
8	Raise Magnet	0 min 10 sec
9	2 min delay	2 min 0 sec
10	Remove Supernatant 1 (65 μ L/well)	0 min 37 sec
11	Release Magnet	0 min 10 sec
12	Bead Wash 2x (60 μ L/well)	1 min 3 sec
13	Raise Magnet	0 min 10 sec
14	2 min delay	2 min 0 sec
15	Remove Supernatant 1 (65 μ L/well)	0 min 37 sec

STEPS	ACTION	DURATION
16	Release Magnet	0 min 10 sec
17	Bead Wash 3x (60 µL/well)	1 min 3 sec
18	Raise Magnet	0 min 10 sec
19	2 min delay	2 min 0 sec
20	Remove Supernatant 1 (65 µL/well)	0 min 37 sec
21	Release Magnet	0 min 10 sec
22	Binding Buffer 1 (55 µL/well)	0 min 58 sec
23	Mix Binder Beads 1	0 min 54 sec
24	Check Strep Bead Resuspension	0
25	Additional Mixing Required	0
26	Load Lysates	0
27	Add Binder Beads (50 µL/well)	1 min 34 sec
28	Vortex at 800 - 1000 RPM	0
29	Cover Reagents	0
30	Remove and Store Rgt Plate	0

Section 2.3. Streptavidin Beads Wash

WT S2 St3 V4_0 VOYAGER

STEPS	ACTION	DURATION
1	Initial Volumes	0
2	Raise Magnet	0 min 10 sec

STEPS	ACTION	DURATION
3	2 min Delay	2 min 0 sec
4	Remove Supernatant 1 (125 µL/well)	0 min 46 sec
5	Release Magnet	0 min 10 sec
6	Add Wash A.1 (120 µL/well)	1 min 51 sec
7	Slow Wash A.1	0 min 30 sec
8	Raise Magnet	0 min 10 sec
9	2 min Delay	2 min 0 sec
10	Volume Change	0
11	Remove Supernatant 1 (125 µL/well)	0 min 46 sec
12	Release Magnet	0 min 10 sec
13	Add Wash B.1 (120 µL/well)	1 min 51 sec
14	Slow Wash B.1	0 min 30 sec
15	Proceed to next step	0

Section 2.4. Master Mixes Preparation

WT S2 St4 V4_0 DONE

STEPS	ACTION	DURATION
1	Initial Volumes	0
2	Dispense SPRI Beads (90 µL/well)	1 min 0 sec
3	cDNA Amp Primer (517 µL/well)	0 min 29 sec
4	cDNA PCR Add (11 µL/well)	0 min 33 sec

STEPS	ACTION	DURATION
5	Mix cDNA MM	0 min 45 sec
6	Dispense cDNA MM 1.1 (60 µL/well)	0 min 57 sec
7	cDNA Amp Enz (60 µL/well)	0 min 58 sec
8	Store cDNA MM on Ice	0
9	TS Buffer 1.1 (725 µL/well)	0 min 44 sec
10	TS Enz 1.1 (50 µL/well)	0 min 38 sec
11	TS Primer 1.1 (25 µL/well)	0 min 33 sec
12	TS Mix 1.1	1 min 39 sec
13	Dispense TS MM 1.1 (90 µL/well)	1 min 19 sec
14	Remove Parse Cold Block	0
15	Remove Reagent Plate	0
16	Proceed to next step	0

Section 2.5. Template Switch and cDNA Amplification

WT S2 St5 V4_0 VOYAGER

STEPS	ACTION	DURATION
1	Initial Volumes	0
2	Raise Magnet	0 min 10 sec
3	DELAY	2 min 0 sec
4	Remove Supernatant 1 (125 µL/well)	0 min 37 sec
5	Release Magnet	0 min 10 sec

STEPS	ACTION	DURATION
6	Add Water 1 (20 µL/well)	0 min 42 sec
7	Add TS 1 (80 µL/well)	1 min 24 sec
8	Cover 8 Reagents	0
9	Incubate 30 mins	0
10	Run TS on Therm	0
11	Load Cold Block	0
12	Reload Samples	0
13	Labware Change	0
14	Volume Change	0
15	Raise Magnet	0 min 10 sec
16	DELAY	2 min 0 sec
17	Remove TS Sup 1 (125 µL/well)	0 min 37 sec
18	Release Magnet	0 min 10 sec
19	Add Wash A1 (120 µL/well)	1 min 14 sec
20	Volume Change	0
21	Raise Magnet	0 min 10 sec
22	DELAY	2 min 10 sec
23	Remove Wash A1 (125 µL/well)	0 min 37 sec
24	Release Magnet	0 min 10 sec
25	Add Wash B1 (120 µL/well)	1 min 14 sec

STEPS	ACTION	DURATION
26	Load cDNA	0
27	Volume Change	0
28	Raise Magnet	0 min 10 sec
29	DELAY	2 min 10 sec
30	Remove Wash B1 (125 μ L/well)	0 min 37 sec
31	Release Magnet	0 min 10 sec
32	Add cDNA Primer (50 μ L/well)	0 min 46 sec
33	Add cDNA Enz (50 μ L/well)	1 min 4 sec
34	Run cDNA on Therm	0

Section 2.6. Post-Amplification Purification

WT S2 St6 V4_0 VOYAGER

STEPS	ACTION	DURATION
1	Initial Volumes	0
2	Mix Samples	0 min 30 sec
3	Raise Magnet	0 min 10 sec
4	Mix SPRI Beads	0 min 44 sec
5	DELAY	0 min 30 sec
6	Transfer 90uL 1 (90 μ L/well)	0 min 33 sec
7	Release Magnet	0 min 10 sec
8	Add SPRI Beads (72 μ L/well)	1 min 47 sec

STEPS	ACTION	DURATION
9	DELAY	5 min 0 sec
10	Raise Magnet	0 min 10 sec
11	DELAY	6 min 0 sec
12	Volume Change	0
13	Remove Sup 1 (100 µL/well x 2)	1 min 14 sec
14	Add EtOH 1x (90 µL/well x 2)	0 min 51 sec
15	Volume Change	0
16	Remove Sup 1 (100 µL/well x 2)	1 min 14 sec
17	Add EtOH 2x (90 µL/well x 2)	0 min 51 sec
18	Volume Change	0
19	Remove Sup 1 (100 µL/well x 2)	1 min 14 sec
20	DELAY	2 min 0 sec
21	Release Magnet	0 min 10 sec
22	Elute (25 µL/well)	0 min 49 sec
23	DELAY	5 min 0 sec
24	Raise Magnet	0 min 10 sec
25	DELAY	2 min 0 sec
26	Volume Change	0
27	Load New Plate	0
28	Elution Transfer (30 µL/well)	0 min 31 sec

STEPS	ACTION	DURATION
29	Release Magnet	0 min 10 sec
30	Samples on Deck B	0

Section 3.0. cDNA Normalization

WT S3 St0 V4_0 DONE

STEPS	ACTION	DURATION
1	Initial Volumes	0
2	Section3NormWTWorksheet	12 min 0 sec

Section 3.1. SPRI Bead Plating

WT S3 St1 V4_0 DONE

STEPS	ACTION	DURATION
1	Initial Volumes	0
2	Lower Magnet	0 min 10 sec
3	Plate out beads (60 μ L/well)	1 min 11 sec
4	Plate out beads (95 μ L/well)	1 min 20 sec
5	Plate out beads (50 μ L/well)	1 min 8 sec

Section 3.2. Fragmentation Mix Creation and Plating

WT S3 St2 V4_0 DONE

STEPS	ACTION	DURATION
1	Initial Volumes	0
2	Pre-chill thermal cyler	0

STEPS	ACTION	DURATION
3	Mix	0 min 14 sec
4	Distribute	0 min 7 sec
5	Plate out master mix (15 μ L/well)	1 min 51 sec
6	Proceed immediately to S3 St3	0

Section 3.3. Fragmentation Mix Addition and Post-Fragmentation SPRI Cleanup

WT S3 St3 V4_0 VOYAGER

STEPS	ACTION	DURATION
1	Initial Volumes	0
2	Stamp master mix into samples (15 μ L/well)	0 min 42 sec
3	Run Frag	0
4	Replace Deck B with thawed freezer block	0
5	Move bead/reagent plate to Deck B	0
6	Add water and ETOH	0
7	Reload Plate	0
8	Reset volumes to reflect swapped plates	0
9	Ensure magnet is in Low position	0 min 10 sec
10	Mix beads	0 min 36 sec
11	Mix beads	0 min 36 sec
12	Add beads to sublibraries (30 μ L/well)	0 min 54 sec
13	5 Minute RT Incubation	5 min 0 sec

STEPS	ACTION	DURATION
14	Activate Magnet	0 min 10 sec
15	2 Minute Bead Immobilize	2 min 0 sec
16	Transfer Supernatant (75 μ L/well)	0 min 49 sec
17	Deactivate Magnet	0 min 10 sec
18	Add beads to sublibraries (20 μ L/well)	0 min 53 sec
19	5 Minute RT Incubation	5 min 0 sec
20	Activate Magnet	0 min 10 sec
21	3 Minute Bead Immobilize	3 min 0 sec
22	Allow for Over-Aspiration	0
23	Discard Supernatant (90 μ L/well)	0 min 51 sec
24	EtOH Addition 1 (90 μ L/well)	0 min 26 sec
25	EtOH Addition 1 (90 μ L/well)	0 min 26 sec
26	1 Minute RT Incubation	1 min 0 sec
27	Discard EtOH (95 μ L/well)	0 min 47 sec
28	Discard EtOH (95 μ L/well)	0 min 47 sec
29	EtOH Addition 2 (90 μ L/well)	0 min 26 sec
30	EtOH Addition 2 (90 μ L/well)	0 min 26 sec
31	1 Minute RT Incubation	1 min 0 sec
32	Discard EtOH (95 μ L/well)	0 min 47 sec
33	Discard EtOH (95 μ L/well)	0 min 47 sec

STEPS	ACTION	DURATION
34	Air Dry Beads	0 min 15 sec
35	Deactivate Magnet	0 min 10 sec
36	Resuspend Beads in Water (50 µL/well)	0 min 42 sec
37	Mix to Resuspend	0 min 27 sec
38	Mix to Resuspend	0 min 27 sec
39	5 Minute RT Incubation	5 min 0 sec
40	Activate Magnet	0 min 10 sec
41	2 Minute Bead Immobilize	2 min 0 sec
42	Transfer Eluate (50 µL/well)	0 min 41 sec
43	Deactivate Magnet	0 min 10 sec

Section 3.4. Ligation Mix Creation and Plating

WT S3 St4 V4_0 DONE

STEPS	ACTION	DURATION
1	Initial Volumes	0
2	Mix	0 min 37 sec
3	Distribute	0 min 7 sec
4	Try to reduce tip losses	0 min 58 sec
5	Plate out master mix (52 µL/well)	1 min 8 sec
6	Proceed immediately to S3 St5	0

Section 3.5. Ligation Mix Addition and Post-Ligation SPRI Cleanup

WT S3 St5 V4_0 VOYAGER

STEPS	ACTION	DURATION
1	Initial Volumes	0
2	Stamp master mix into samples (50 μ L/well)	1 min 2 sec
3	Run Adapter Ligation	0
4	Add ETOH	0
5	Reload Plate	0
6	Ensure magnet is in Low position	0 min 10 sec
7	Mix beads	0 min 47 sec
8	Mix beads	0 min 47 sec
9	Add beads to sublibraries (80 μ L/well)	1 min 28 sec
10	5 Minute RT Incubation	5 min 0 sec
11	Activate Magnet	0 min 10 sec
12	5 Minute Bead Immobilize	5 min 0 sec
13	Allow for Over-Aspiration	0
14	Discard Supernatant (93 μ L/well)	0 min 28 sec
15	Discard Supernatant (93 μ L/well)	0 min 43 sec
16	EtOH Addition 1 (90 μ L/well)	0 min 26 sec
17	EtOH Addition 1 (90 μ L/well)	0 min 26 sec
18	1 Minute RT Incubation	1 min 0 sec

STEPS	ACTION	DURATION
19	Discard EtOH (95 µL/well)	0 min 47 sec
20	Discard EtOH (95 µL/well)	0 min 47 sec
21	EtOH Addition 2 (90 µL/well)	0 min 26 sec
22	EtOH Addition 2 (90 µL/well)	0 min 26 sec
23	1 Minute RT Incubation	1 min 0 sec
24	Discard EtOH (95 µL/well)	0 min 47 sec
25	Discard EtOH (95 µL/well)	0 min 47 sec
26	Air Dry Beads	2 min 0 sec
27	Deactivate Magnet	0 min 10 sec
28	Resuspend Beads in Water (23 µL/well)	0 min 30 sec
29	5 Minute RT Incubation	5 min 0 sec
30	Activate Magnet	0 min 10 sec
31	2 Minute Bead Immobilize	2 min 0 sec
32	Transfer Eluate (21 µL/well)	0 min 32 sec
33	Deactivate Magnet	0 min 10 sec

Section 3.6. Barcoding Round 4

WT S3 St6 V4_0 DONE

STEPS	ACTION	DURATION
1	Initial Volumes	0
2	Plate out Amp Mix (30 µL/well)	1 min 51 sec

STEPS	ACTION	DURATION
3	Add UDIs	0
4	Proceed immediately to S3 St7	0

Section 3.7. Library Amp Mix Addition and Size Selection

WT S3 St7 V4_0 VOYAGER

STEPS	ACTION	DURATION
1	Initial Volumes	0
2	Stamp Amp Mix into samples (25 μ L/well)	0 min 44 sec
3	Run Indexing PCR	0
4	Add EtOH	0
5	Reload Plate	0
6	Ensure magnet is in Low position	0 min 10 sec
7	Mix beads	0 min 36 sec
8	Mix beads	0 min 36 sec
9	Add beads to sublibraries (30 μ L/well)	0 min 54 sec
10	5 Minute RT Incubation	5 min 0 sec
11	Activate Magnet	0 min 10 sec
12	2 Minute Bead Immobilize	2 min 0 sec
13	Transfer Supernatant (75 μ L/well)	0 min 49 sec
14	Deactivate Magnet	0 min 10 sec
15	Add beads to sublibraries (10 μ L/well)	0 min 49 sec

STEPS	ACTION	DURATION
16	5 Minute RT Incubation	5 min 0 sec
17	Activate Magnet	0 min 10 sec
18	3 Minute Bead Immobilize	3 min 0 sec
19	Allow for Over-Aspiration	0
20	Discard Supernatant (90 μ L/well)	0 min 51 sec
21	EtOH Addition 1 (90 μ L/well)	0 min 26 sec
22	EtOH Addition 1 (90 μ L/well)	0 min 26 sec
23	1 Minute RT Incubation	1 min 0 sec
24	Discard EtOH (95 μ L/well)	0 min 47 sec
25	Discard EtOH (95 μ L/well)	0 min 47 sec
26	EtOH Addition 2 (90 μ L/well)	0 min 26 sec
27	EtOH Addition 2 (90 μ L/well)	0 min 26 sec
28	1 Minute RT Incubation	1 min 0 sec
29	Discard EtOH (95 μ L/well)	0 min 47 sec
30	Discard EtOH (95 μ L/well)	0 min 47 sec
31	Air Dry Beads	0 min 15 sec
32	Deactivate Magnet	0 min 10 sec
33	Resuspend Beads in Water (20 μ L/well)	0 min 29 sec
34	Mix to Resuspend	0 min 23 sec
35	Mix to Resuspend	0 min 23 sec

STEPS	ACTION	DURATION
36	5 Minute RT Incubation	5 min 0 sec
37	Activate Magnet	0 min 10 sec
38	2 Minute Bead Immobilize	2 min 0 sec
39	Transfer Eluate (20 μ L/well)	0 min 32 sec
40	Deactivate Magnet	0 min 10 sec

Appendix D: Troubleshooting

Error warning during the execution of a program

- In case of an error warning, abort the program. Do not press "RUN". Scroll down "Run from step". You can then continue from the error location. This allows to resume directly from the point of error.

Tip Pinching

- Tip pinching may occur when using a newly frozen PCR freezer block for a plate pooling step. Ensure that your PCR Freezer Block has been thawed at room temperature for at least 10 minutes.
- Ensure to apply sufficient pressure when placing the plate onto the frozen PCR freezer block.

Incorrect tip location inputted

- The D-ONE Pipette will check the pipette tips before the step starts. The ASSIST PLUS will display an error warning if a pipette tip is incorrectly detected. Abort and restart the program with the correct tip location input.
- The VIAFLO will check the pipette tip after the step is finished. The ASSIST PLUS will display an error warning if a pipette tip is incorrectly detected. Abort and restart the program with the correct tip location input.

Appendix E: Revision History

Version	Description	Date
1.0	Initial release	June 2026

Appendix F: Acknowledgements

All graphics were created with [BioRender.com](https://www.biorender.com).



PARSE
BIOSCIENCES

A QIAGEN company

parsebiosciences.com

support@parsebiosciences.com



Scan code
to visit site

