

User Manual

Version 1.4 - UMWT3500INT



Evercode™ WT Mega with INTEGRA ASSIST PLUS

For use with

ECWT3500

INTEGRA ASSIST PLUS



Support Suite

Legal Notices

This document and its contents are proprietary to Parse Biosciences, Inc. (“Parse Biosciences”) and are intended solely for use by its customers in connection with the use of the product(s) described herein and for no other purpose. The products may be used solely FOR RESEARCH PURPOSES, AND MAY NOT BE USED IN ANY DIAGNOSTIC OR THERAPEUTIC USE IN HUMANS OR ANIMALS. This document and its contents shall not be used or distributed for any other purpose and/ or otherwise communicated, disclosed or reproduced in any way whatsoever without the prior written consent of Parse Biosciences.

No rights are granted under this document with respect to any of Parse Biosciences’ intellectual property rights. The license to use of any products described herein is subject to a separate written agreement between Parse Biosciences and the applicable user.

The instructions in this document must be strictly and explicitly followed by qualified and properly trained personnel in order to ensure the proper and safe use of the product(s) described herein. Parse Biosciences shall have no liability for any direct, indirect, consequential or incidental damages arising out of any failure to use the product(s) in strict compliance with the terms herein.

This document may contain references to third-party sources of information, hardware or software, products, or services and/ or third-party web sites (collectively “Third Party Information”). Parse Biosciences does not control, and is not responsible for, any Third Party Information. The inclusion of Third Party Information in this document does not imply endorsement by Parse Biosciences of the Third Party Information or the third party in any way.

The product(s) described in this document are provided for one-time use by the purchaser and may not be re-used, refurbished or resold. In addition, such product(s) may not be altered, changed or modified by anyone other than Parse Biosciences and its authorized agents, and Parse Biosciences will not be liable for any such alterations, changes or modifications. The product(s) described herein may be covered by one or more of the following patents:

U.S. Pat. No. 10,900,065

U.S. Pat. No. 11,168,355

U.S. Pat. No. 11,427,856

U.S. Pat. No. 11,634,751

U.S. Pat. No. 11,639,519

U.S. Pat. No. 11,680,283

Patents pending in the U.S. and other countries

PARSE and EVERCODE are trademarks of Parse Biosciences, Inc. The information made available herein is the sole property of Parse Biosciences and its licensors.

Copyright (c) 2024-2025 Parse Biosciences, Inc. All Rights Reserved.

Table of Contents

Overview	5
Workflow	5
Important Guidelines	9
Parse Reagents.....	16
Parse-Provided Equipment	20
INTEGRA Components.....	21
Consumables and Reagents	22
Equipment	24
Reading and Understanding Visuals and Diagrams	25
Section 1: Automation Setup & In Situ Barcoding	28
1.1. Sample Normalization.....	28
1.2. Load and Pool Round 1	37
1.3. Round 2 Ligation Preparation	41
1.4. Round 2 Ligation	47
1.5. Round 3 Ligation Preparation	53
1.6. Round 3 Ligation	58
1.7. Pre-Lysis.....	62
1.8. Lysis and Sublibrary Generation.....	70
Section 2: cDNA Capture and Amplification.....	73
2.1. Reagents Plating.....	73
2.2. cDNA Capture.....	79

2.3. Streptavidin Beads Wash	82
2.4. Master Mixes Preparation	83
2.5. Template Switch and cDNA Amplification	87
2.6. Post-Amplification Purification	95
2.7. cDNA Quantification	98
Section 3: Sequencing Library Preparation.....	99
3.0. cDNA Normalization (Optional)	99
3.1. SPRI Bead Plating	105
3.2. Fragmentation Mix Creation and Plating.....	108
3.3. Fragmentation Mix Addition and Post-Fragmentation SPRI Cleanup	112
3.4. Ligation Mix Creation and Plating	117
3.5. Ligation Master Mix Addition and Post-Ligation SPRI Cleanup	120
3.6. Barcoding Round 4.....	124
3.7. Library Amp Mix Addition and Size Selection	128
3.8. Sequencing Library Quantification.....	133
Appendices	134
Appendix A: Sequencing Information	134
Appendix B: Pipetting Programs	137
Appendix C: Troubleshooting	153
Appendix D: Revision History.....	154
Appendix E: Acknowledgements	154

Overview

Workflow

The Evercode combinatorial barcoding workflow is compatible with the INTEGRA ASSIST PLUS to enable large-scale single cell RNA-Seq experiments through a robust, semi-automated process.

The Evercode WT Mega v3 kit can profile up to 1,000,000 cells across up to 96 different biological samples or experimental conditions. Evercode Fixation kits first fix and permeabilize cells/nuclei so they act as individual reaction compartments.

Through four rounds of barcoding, the transcriptome of each fixed cell/nuclei is uniquely labeled. The four rounds of barcoding can yield a very large number of possible barcode combinations which is more than sufficient to uniquely label up to 1,000,000 cells/nuclei while avoiding doublets.

After sequencing, the Parse Biosciences Analysis Pipeline assigns reads with the same four barcode combination to a single cell/nuclei.

By integrating the Evercode Mega assay kits with the ASSIST PLUS platform, the semi-automated workflow performs sample normalization and combinatorial barcoding through a series of reverse transcription, ligation, and library preparation steps.

The table below provides a high-level overview of the automated barcoding workflow.

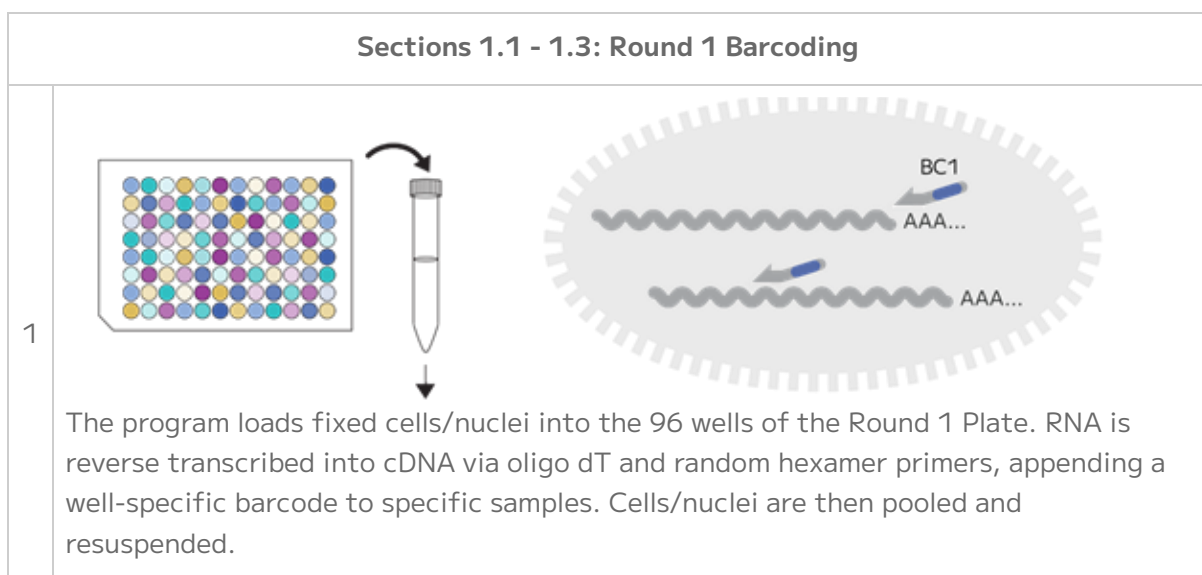

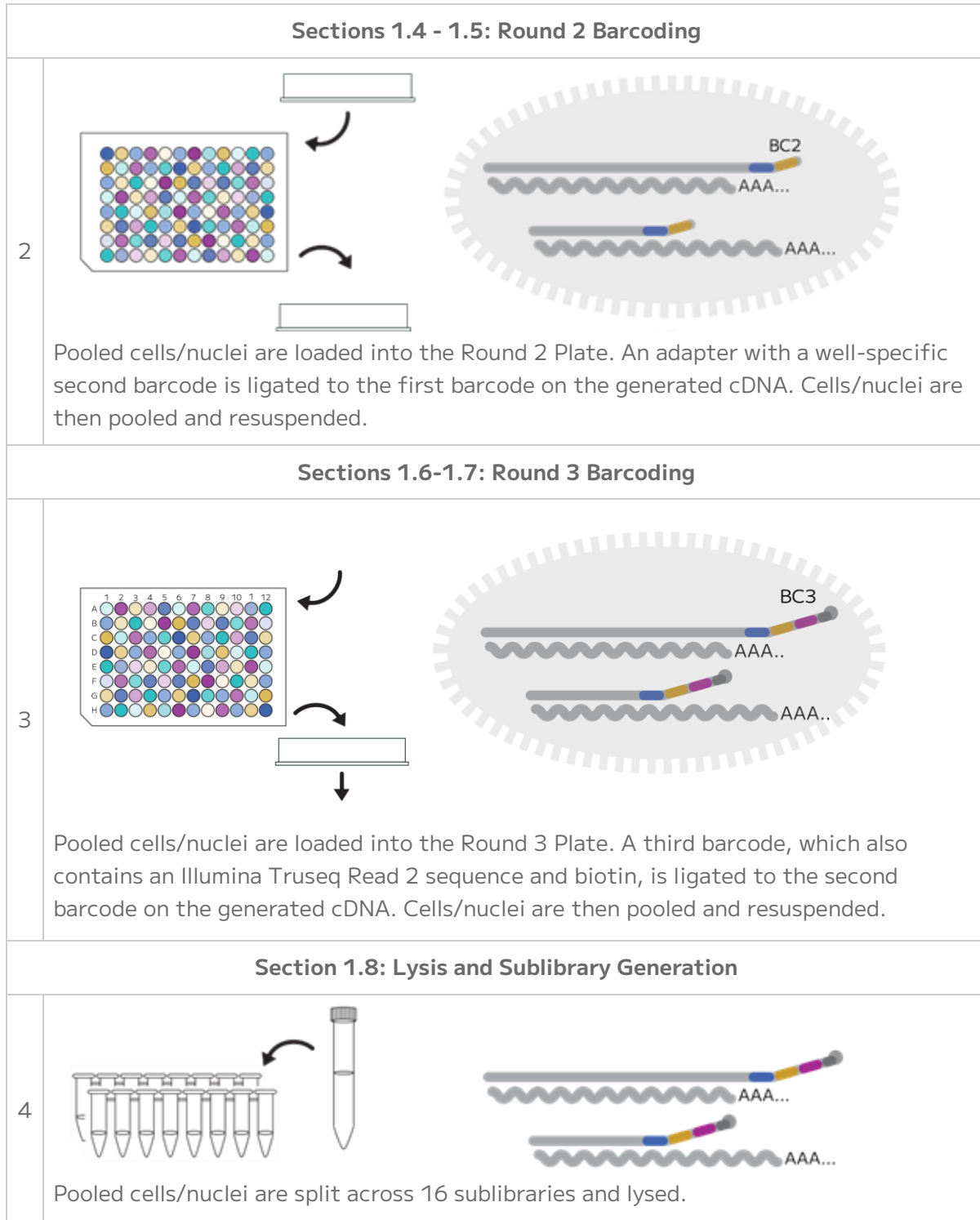

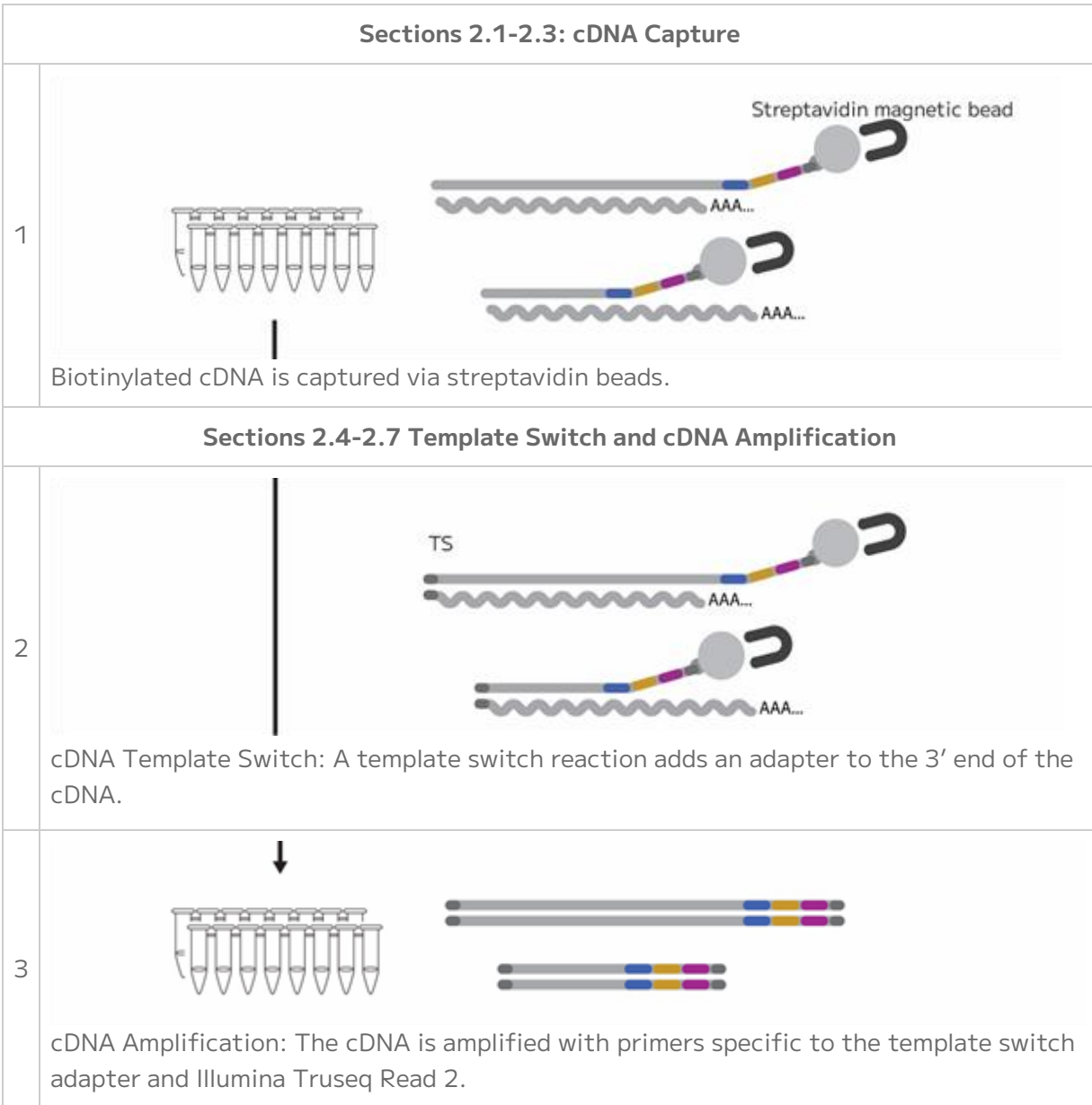

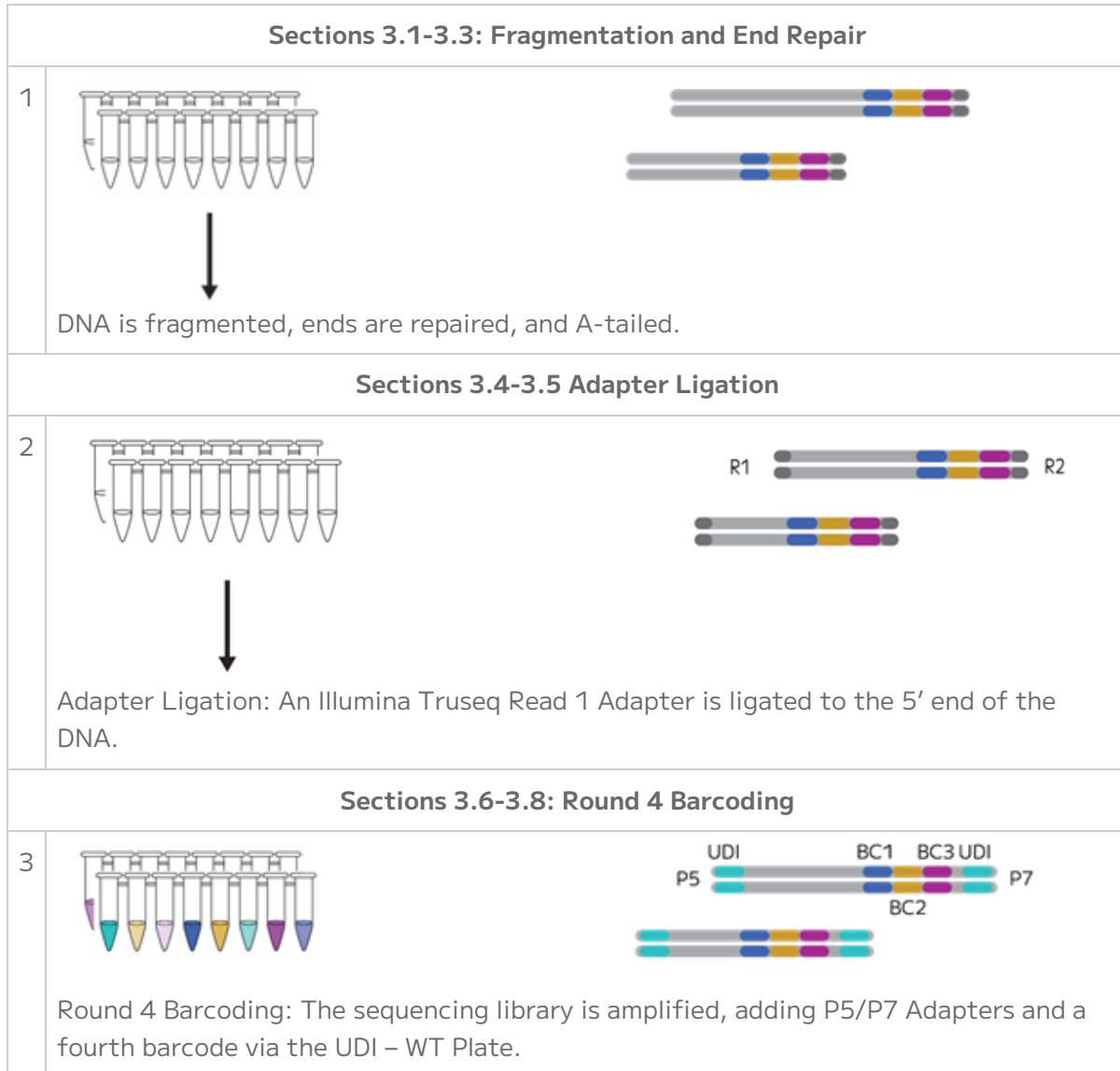

This protocol is intended to be followed when performing the Evercode Mega assays on the INTEGRA ASSIST PLUS liquid handler. The protocol replaces "Section 1. *In Situ* Cell/Nuclei Barcoding", "Section 2. cDNA Capture and Amplification", and "Section 3. Sequencing Library Amplification" of the standard [Evercode WT Mega v3 User Guide](#).

Important Guidelines

The following guidelines provide additional information to obtain optimal performance with the Evercode WT Mega v3 with INTEGRA ASSIST PLUS barcoding workflow.

Comprehensive guidance on optimizing the complete standard Evercode WT Mega v3 workflow is provided in the Evercode WT Mega v3 User Guide. For further information on the experimental or automation workflow, please contact support@parsebiosciences.com. Please contact support-us@integra-biosciences.com for any questions regarding the INTEGRA ASSIST PLUS instrument.

Sample Input

- This protocol begins with cells or nuclei previously fixed with an Evercode Cell Fixation v3 or Evercode Nuclei Fixation v3 kit.
- Samples fixed with the Standard Fixation kits are fully compatible with the INTEGRA automated barcoding workflow. To barcode samples previously fixed with the Low Input Fixation kits, we recommend beginning the automated workflow after the Barcoding 1 filter step:
 - Follow the standard User Manual instructions for the manual workflow, covering steps from Section 1.1.1 through Section 1.2.8.
 - Switch to User Manual for the automated workflow beginning with Section 1.2.1.
- Even if samples were counted before freezing, we strongly recommend counting cells/nuclei again after thawing to account for any changes in cell/nuclei concentration during storage and freeze/thaw. Typically, a 5-15% decrease in concentration after thawing should be expected. These counts are used to determine how cells/nuclei are loaded in the Round 1 Plate, and counting accuracy at this stage is critical to recover the desired number of cells/nuclei following barcoding.
- When planning on processing many fixed samples, we recommend setting aside a small "counting aliquot" of each sample at the end of fixation. These counting aliquots can be counted the day prior to starting Section 1 of any Evercode assay kit. The Evercode Fixation User Guides outline recommendations for generating aliquots. Because aliquots have undergone a similar storage time and a freeze/thaw, cell/nuclei counts from these aliquots will be more representative than using counts from immediately after fixation.
- Aliquots should be thawed in a water bath set to 37°C in sets of 2-4 and counted with a hemocytometer or alternative counting device. Cell/nuclei counts should be recorded in the Sample Loading Table, and any remaining cell/nuclei material in the thawed counting aliquot should be discarded.

- Once fixed samples have been thawed, they should not be refrozen.
- Samples need to be diluted into a dilution plate prior to Round 1 Barcoding. The Sample Loading Table will recommend the appropriate volume of dilution buffer needed to achieve the correct cell concentration in the required volume. If the required "Number of Sample Dilution Tubes" is greater than 1, three additional dilution buffer tubes for highly concentrated samples can be purchased as a Sample Dilution Accessory Kit (PN ECAC3901). This kit is included in the initial INTEGRA bundle, but will need to be separately purchased for subsequent orders.

Cell/Nuclei Counting and Quality Assessment

- We recommend a hemocytometer for counting, but alternative counting devices can also be used. If possible, validate counts from alternative devices against a hemocytometer when using Evercode kits for the first time.
- We suggest saving images of cells/nuclei at each counting step. A 20x and 40x magnification provide the most useful information.
- To assess sample quality, we recommend using viability stains like trypan blue or acridine orange and propidium iodide (AO/PI).
- Examples of trypan blue stained fixed cells are shown below. High quality fixed samples have single distinct cells/nuclei with <5% cell aggregation and no debris. Higher levels of aggregation will lead to elevated doublets after sequencing. When quantifying fixed samples, it is critical to avoid counting cell debris to avoid overestimating the number of cells/nuclei.

High Quality Sample

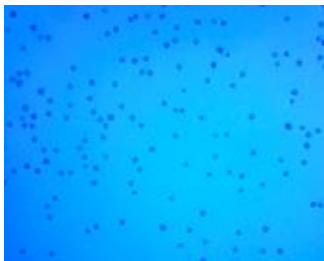

Aggregation



Debris

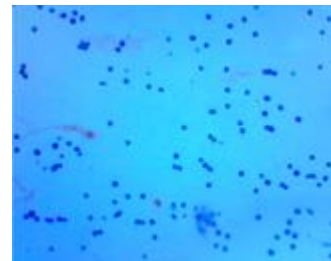

Example trypan blue stained fixed cells.

Avoiding RNase Contamination

- Take standard precautions to avoid introducing RNases into samples or reagents throughout the workflow. Always wear proper laboratory gloves and use aseptic technique.

- Although RNases are not inactivated by ethanol or isopropanol, they are inactivated by products such as RNaseZap™ RNase Decontamination Solution (Thermo Fisher Scientific®). These can be sprayed on benchtops and pipettes.
- Low retention, filtered pipette tips should be used to reduce RNase contamination from pipettes.

Centrifugation

- A range of centrifugation speeds and durations are provided in this workflow in order to optimize and balance high sample retention with resuspension efficiency. Comprehensive information to optimize centrifugation conditions for each sample type is provided in the Cells and Nuclei Fixation User Guides.
- Use a swinging bucket rotor for all high-speed centrifugation steps in this workflow. A fixed-angle rotor will lead to substantial cell/nuclei loss.

Sample Loading Table

- Ensure that the Parse Evercode WT INTEGRA Mega Sample Loading Table being used is the most up-to-date version. The Sample Loading Table can be downloaded from the Parse Biosciences [Customer Support Suite](#). Customer log-in is required to access the Sample Loading Table.
- The Parse Evercode WT INTEGRA Mega Sample Loading Table (Excel spreadsheet) should be completed before starting the experiment.
- If the table isn't working as expected, ensure that Macros are enabled in the Sample Loading Table. Be sure to only edit the colored cells in the table to avoid disturbing any calculations.
- In the unlikely event that samples are not concentrated enough according to the Sample Loading Table (Excel spreadsheet), choose to either:
 - Decrease the "Max number barcoded cells" until the Sample Loading Table no longer gives an error. This will maintain the desired final library proportion between samples but barcode fewer total cells/nuclei.
 - Proceed as-is. The INTEGRA pipette will dispense the highest possible number of cells based on the existing concentration. This may lead to reduced library yields for samples with particularly low concentrations.

Indexing Primers

- The Evercode Mega v3 kit includes the UDI Plate - WT. The UDI Plate - WT box is included in the INTEGRA bundles but will need to be separately purchased if necessary for subsequent orders.
- The UDI Plate - WT is a 96-well plate containing 48 unique dual indexing (UDI) primers. Each well is a single-use reaction sufficient for one Barcoding Round 4 PCR reaction for a single sublibrary. Thus, the UDI Plate - WT can be used for multiple Evercode kits.
- The UDI Plates are sealed with a pierceable foil to minimize cross-contamination. The plate seal should be wiped with 70% ethanol and pierced with a new pipette tip immediately prior to use. Avoid splashing or mixing the liquid between individual wells. Once a well has been used, it should not be resealed or reused.
- We recommend selecting UDIs column-wise from left to right (starting with indices 1-8). UDI sequences can be found in Appendix A.

Plate Sealing

- When sealing or unsealing 96 well plates, do not splash liquid onto the PCR plate seal or between wells. Securing plates in PCR tube racks will minimize this occurrence.
- PCR plate seals may be difficult to remove. Carefully peel off the PCR plate seal while applying downward pressure on the edges of the plate to keep it in the PCR plate rack. Avoid touching the top of the open wells.

Basin Liners Usage

- Basin liners are used throughout the procedure for reagent storage. Do not use SureFlo basins, as their microwell design—intended to minimize dead volume—can unintentionally trap cells or nuclei, resulting in poor retention. Validated basins are listed in the Consumables and Reagents section.

Sample Concentrations

- For an Evercode Mega kit, samples can be pre-diluted with Sample Dilution Buffer to a more appropriate working range of 2,125-8,000 cells/nuclei per μL prior to Sample Normalization on the ASSIST PLUS.
- Samples need to be diluted with Sample Dilution Buffer to the desired concentration based on the Sample Loading Table.
- For each sample we recommend preparing a 20 μL post-fixation counting aliquot and two 30-50 μL post-fixation sample aliquots. Prior to aliquoting, the samples should be

thoroughly resuspended. The counting aliquot may be thawed in advance of the barcoding day to evaluate post-thaw cell recovery. The cell/nuclei loss observed in this aliquot is expected to closely reflect that of the sample aliquots. Concentrations measured from the counting aliquot can then be used to update the Sample Loading Table accordingly.

- If the sample stock concentrations are too high the Sample Loading Table may indicate that more than 1 tube of Sample Dilution Buffer is needed. Additional Sample Dilution Buffer can be purchased in the Dilution Accessory Box (Parse PN ECAC3901) before starting the barcoding workflow.

Thermochromic PCR Cold Block

- The Thermochromic PCR Cold Block changes color from dark purple to bright pink (too warm) when the block temperature exceeds 7°C. If greater than 30% of the block is bright pink, replace the Thermochromic PCR Cold Block with a fully frozen dark purple block.
- To maintain optimal performance and minimize temperature fluctuations, store the Thermochromic PCR Cold Blocks in a -20°C freezer when not in use. The blocks should be stored upside down to prevent warping.
- The Thermochromic PCR Cold Block Riser needs to be installed in the Thermochromic PCR Cold Block prior to use as illustrated below. The Riser does not need to be removed when freezing.

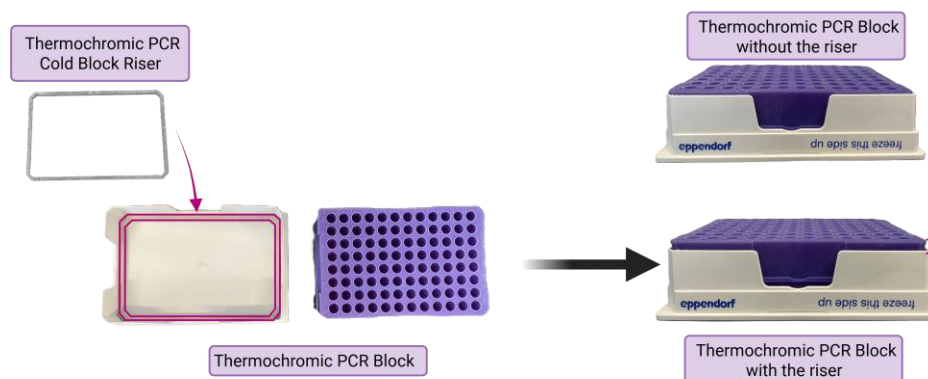

Note: Uneven freezing of the liquid inside the Thermochromic PCR Block can cause slanting of the cooling position. The Thermochromic PCR Cold Block Riser reduces the variability caused by the freezing process. If the PCR Cold Block riser is not used, there will be extra liquid left in the wells of the PCR plate during aspiration steps.

- Tip pinching may occur when using a fully frozen Thermochromic PCR Cold Block for a plate pooling step. To minimize tip pinching, a fully frozen block should be warmed

slightly by a few degrees by leaving it at room temperature for 10 minutes before using it on the INTEGRA ASSIST PLUS Deck.

- To ensure a secure positioning within the Thermochromic PCR Cold Block, apply firm pressure on the PCR plates until they are securely seated. Avoid touching the top of the open wells.

Bases and Reservoirs

- Both the 300 mL Reservoir Base and the 8-Row Polystyrene Reservoir are consumables that must be purchased from INTEGRA. The 300 mL Reservoir Base is designed to securely hold the 8-Row Reservoir in place during use.

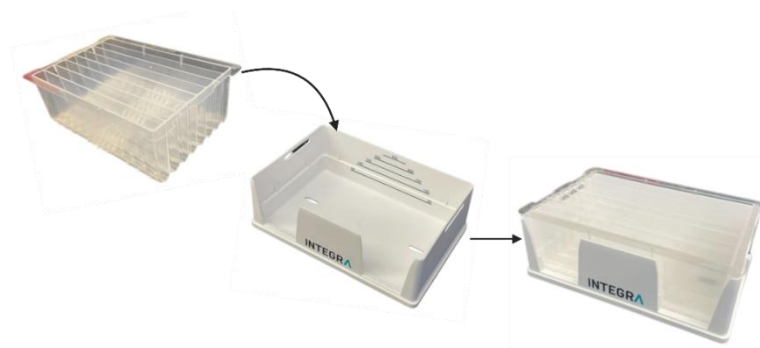

INTEGRA ASSIST PLUS Pipetting Programs

- Ensure that the VIALAB program is installed on the same Windows computer that will be used to communicate with the D-ONE Pipetting Module.
- Ensure that the Evercode workflow precheck script has been confirmed prior to running the INTEGRA + Parse workflow. This can be done by running the [Evercode WT with INTEGRA ASSIST PLUS Precheck Scripts](#) available on the Customer Support Suite.
- Ensure that the .csv worklists generated via the Parse Evercode WT INTEGRA Mega Sample Loading Table ("CombinedMegaWorksheet_YYYYMMDD_HHMMSS.csv") are accessible for upload to the VIALAB program.
- Automated pipetting programs are set up and can be selected using the pipette's user interface. In the INTEGRA + Parse workflow, prompts are built into the programs as checkpoints. When the prompt is followed by a double dash, "--", the program will continue. If the prompt does not contain a double dash, "--", it is followed by another prompt.

Deck Loading

- Always ensure the tip box placed on the deck clicks when put into place. Remove the tip box lid prior to starting the program.
- To prevent malfunctions during the procedure, ensure that all unnecessary labware is cleared from the deck before initiating a new program on the INTEGRA ASSIST PLUS.







Parse Reagents

The Evercode WT Mega v3 kit includes the following boxes. Safety Data Sheets for these reagents can be provided upon request.



-20°C Reagents Store -20°C, PN MG100

LABEL	ITEM	PN	FORMAT	QTY
	Round 1 Plate	MG101	Green semi-skirted 96 well plate	1
	Round 2 Plate	MG102	Blue semi-skirted 96 well plate	1
	Round 3 Plate	MG103	Yellow semi-skirted 96 well plate	1
	Resuspension Buffer	MG104	5 mL tube	1
	Sample Dilution Buffer	MG105	2 mL tube	1
	Round 2 Ligation Buffer	MG106	5 mL tube	1
	Round 2 Ligation Enzyme	MG107	1.5 mL tube	1
	Round 2 Stop Buffer	MG108	2 mL tube	1
	Round 3 Stop Buffer	MG109	5 mL tube	1
	Pre-Lysis Wash Buffer	MG110	5 mL tube	1

LABEL	ITEM	PN	FORMAT	QTY
	Round 3 Ligation Enzyme	MG111	1.5 mL tube	1
	Pre-Lysis Dilution Buffer	MG112	2 mL tube	1
	Lysis Enzyme	MG113	1.5 mL tube	1
	Bead Wash Buffer	MG114	5 mL tube	1
	Wash Buffer 1	MG115	5 mL tube	1
	Wash Buffer 2	MG116	5 mL tube	1
	Capture Enhancer	MG117	1.5 mL tube	1
	Binding Buffer	MG118	1.5 mL tube	1
	Wash Buffer 3	MG119	5 mL tube	1
	Template Switch Buffer	MG120	2 mL tube	1
	Template Switch Enzyme	MG121	1.5 mL tube	1
	Template Switch Primer	MG122	1.5 mL tube	1
	cDNA Amp Mix	MG123	1.5 mL tube	1
	cDNA Amp Primers	MG124	1.5 mL tube	1

LABEL	ITEM	PN	FORMAT	QTY
	Fragm/End Prep Buffer	MG125	1.5.mL tube	1
	Fragm/End Prep Enzymes	MG126	1.5 mL tube	1
	Ligation Adapter	MG127	1.5 mL tube	1
	Adapter Ligation Buffer	MG128	1.5 mL tube	1
	Adapter Ligation Enzyme	MG129	1.5 mL tube	1
	Library Amp Mix	MG130	1.5 mL tube	1

4°C Reagents. Store 4°C, PN MG200

LABEL	ITEM	PN	FORMAT	QTY
	Spin Additive	MG201	1.5 mL tube	1
	Lysis Buffer	MG202	1.5 mL tube	1
	Streptavidin Beads	MG203	1.5 mL tube	1

The Evercode WT Mega v3 kit requires the following box. Store at -20°C. UDI Plate - WT box is included in the INTEGRA bundles but will need to be separately purchased if necessary for subsequent orders.

ITEM	SUPPLIER	PN	NOTES
UDI Plate - WT	Parse Biosciences	UDI1001	Each 96 well plate contains 48 unique single-use reactions sufficient for multiple Evercode kits (48 sublibraries). UDI Plate - WT can be purchased separately or bundled with Evercode kits.

-20°C Sample Dilution Accessory Kit* Store at -20°C, PN ECAC3901

LABEL	ITEM	PN	FORMAT	QTY
	Sample Dilution Buffer	MG105	2 mL tube	3

*The -20°C Sample Dilution Accessory Kit is optional and can be purchased separately if needed to dilute concentrated samples.

Parse-Provided Equipment

The following is a list of equipment provided by Parse Biosciences, required to successfully perform the Evercode workflows on the INTEGRA ASSIST PLUS.

The equipment listed should be stored at -20°C when not in use and taken out when instructed throughout the protocol.

ITEM	PN	QTY
Thermochromic PCR Cold Block	NTAC1102	3
Thermochromic PCR Cold Block Riser	NTAC1103	3
Parse Metal Cold Block	NTAC1107	1

INTEGRA Components

The following are required INTEGRA ASSIST PLUS components needed to run the Evercode assay on the INTEGRA ASSIST PLUS and should not be substituted.

ITEM	ITEM TYPE	PN	QTY
Pipette Communication Module for VIAFLO / VOYAGER Pipettes	Accessory	4222	3
ASSIST PLUS Slanted Plate Holder (0°-30°)	Adapter	4510	1
Tip Deck for D-ONE Pipetting Module	Base	4535	1
Dual Reservoir Adapter (ANSI/SLAS footprint)	Adapter	4547	1
ASSIST PLUS Labware Pedestal (+24 mm) for D-ONE, portrait, for 10 mL, 25 mL, 100 mL, reservoirs and plates/reservoirs in SLAS/ANSI format (24 mm Labware Pedestal)	Adapter	4551	1
D-ONE Pipetting Module 1-Ch, 5-1250 µL	Pipette	4532	1
VIAFLO Pipette 12-Ch, 5-125 µL	Pipette	4632	1
VOYAGER Pipette 8-Channel, 5 - 125 µL	Pipette	4722	1
ASSIST PLUS Base Unit	Main	4505	1
Communication/Charging Cable for VIAFLO	Accessory	4226	1
HEATMAG module	Module	4901	1
96 Well Adapter for HEATMAG module	Adapter	4906	1

Consumables and Reagents

The following is a list of consumables and reagents required to successfully perform Parse Evercode workflows on the INTEGRA ASSIST PLUS.

INTEGRA Consumables

ITEM	PN	QTY
25 mL Basin Reservoir Liner	4316	7
8 Row Polystyrene Reservoir	6373	2
300 mL Reservoir Bases	6305	1
1250 µL Pipette Tips	6545	as needed
125 µL Pipette Tips	6565	

Other Consumables

ITEM	SUPPLIER	PN	QTY
Sterilized 25 µm, 40 µm, or 70 µm Mini Cell Strainer	DiagnoCine	FNK-HT-AMS-12502 FNK-HT-AMS-14002 FNK-HT-AMS-17002	2
10 mL Transport Tube	GlobeScientific™	6102S	3
1.5 mL Microtube	Genesee Scientific	21-257	6
PCR Strip Tubes	USA Scientific®	1402-4700	11
2 mL Microtubes	Genesee Scientific	21-255	6
Semi-skirted 96 well plates	Eppendorf®	E951020362	4
SealPlate®	Excel Scientific	100-SEAL-PLT	as needed
Pipette Tips TR LTS 20 µL, 200 µL, 1000 µL	Rainin®	17014961 17014963 17014967	as needed

Reagents

ITEM	SUPPLIER	PN	NOTES
AMPure® XP Reagent	Beckman Coulter®	A63880 (5 mL) A63881 (60mL)	Choose one. We do not recommend substituting other magnetic beads.
SPRIselect Reagent	Beckman Coulter	B23317 (5mL) B23318 (60mL)	
KAPA® Pure Beads	Roche®	KK8000 (5 mL) KK8001 (30mL)	
Pipette Tips TR LTS 20 µL, 200 µL, 1000 µL	Rainin®	17014961 17014963 17014967	Or appropriate DNA low-binding, DNase/RNase-free, and filtered pipette tips. Do not use wide bore tips.
RNaseZap™ RNase Decontamination Solution	Thermo Fisher Scientific®	AM9780	Or equivalent RNase decontamination solution.
Ethyl alcohol, Pure	Sigma-Aldrich®	459844	Or equivalent 100% non-denatured ethanol.
Nuclease-Free Water	Sigma-Aldrich	W4502	Or equivalent nuclease-free water.
Trypan Blue	Various Suppliers	Varies	Or alternative dyes to assess cell viability, such as AO/PI.
Qubit dsDNA HS (High Sensitivity) Assay Kit	Thermo Fisher Scientific	Q33230 (100 assays) Q33231 (500 assays)	Or equivalent DNA quantifier.
High Sensitivity DNA Kit	Agilent®	5067-4626	Choose one that corresponds to the chosen Bioanalyzer or TapeStation.
High Sensitivity D5000 ScreenTape and Reagents	Agilent	5067-5592 (screen tape) 5067-5593 (sample buffer and ladder)	

Equipment

The following equipment is required to perform the protocol, but are not provided by INTEGRA or by Parse Biosciences. Note that this list does not include standard laboratory equipment, such as freezers.

Equipment

ITEM	SUPPLIER	PN	NOTES
Centrifuge with Swinging Bucket Rotors	Various Suppliers	Varies	Compatible with 96 well plates and capable of reaching 4°C.
Microcentrifuge	Various Suppliers	Varies	Compatible with 1.5 mL tubes.
Hemocytometer	Sigma-Aldrich®	Z359629	Or other cell counting devices. We recommend validating alternatives relative to a hemocytometer.
Plate Seal Applicator	Various Suppliers	Varies	Capable of adhering plate sealing films to 96 well plates.
T100 Thermal Cycler	Bio-Rad Laboratories®	1861096	Or an equivalent thermocycler compatible with semi-skirted 96 well plates, 0.2mL PCR tubes with up to 100 µL of sample volume, sample heating and cooling from 4-98°C, and a heated lid capable of 30-105°C.
Water bath	Various Suppliers	Varies	Or equivalent thermomixer, heat block, or bead bath capable of holding temperature at 37°C.
Vortex-Genie 2®	Scientific Industries®	SI-0236	Or alternative vortex and adapter for 96 well plates, or a thermomixer or alternative shaker that can be set to 800-1000 RPM.
6-inch Platform	Scientific Industries	146-6005-00	
Microplate Foam Insert	Scientific Industries	504-0235-00	
Qubit™ Flex Fluorometer	Thermo Fisher Scientific	Q33327	Or an equivalent fluorometer.
2100 Bioanalyzer	Agilent®	G2939BA	Choose one.
4200 TapeStation System	Agilent	G2991BA	

Reading and Understanding Visuals and Diagrams

Understanding the figures in this user manual is essential for accurately interpreting the information presented.

While the figures are different, they share consistent formats, use standardized visual elements and follow common conventions.

There are three types of figures in this manual.

- Photos of the hardware configurations, including tip rack, and Decks A, B, and C.
- Visual representation of Decks A, B, and C where consumable labware, reagents, and samples are placed.
- Diagrams of the pipette illustrating the steps to select the appropriate program.

We recommend reviewing this section and the illustrations throughout the manual to familiarize yourself with the visual language used.

Understanding the Hardware Configurations

The hardware configurations appear at the beginning of each subsection and show how to set up the INTEGRA platform to complete the associated steps. This photo displays the tip racks, Deck A, Deck B, and Deck C. Red arrows indicate the order in which tips are picked up by the INTEGRA platform, and required hardware is highlighted with text boxes.

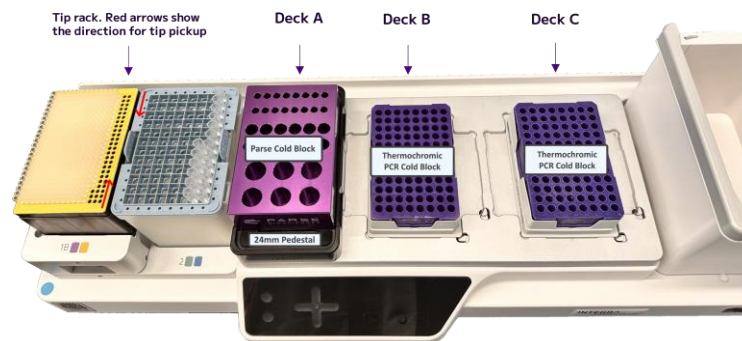

Blocks and Pedestals are hardware components that will be placed or removed as needed throughout the workflow.

Reading and Understanding the Deck Configurations

Each subsection includes multiple deck configurations that illustrate the steps executed by the program. These configurations display the exact placement of reagents and samples on the decks, list the consumables required at each step, and highlight pipette prompts for manual intervention.

Graphical representation of basins and/or tubes with colored outlines show where specific reagents will be added. Each outline color matches the color of the reagent's label.

Color-coded cues guide the user through actions such as loading, moving, or removing hardware, reagents, and consumables, while also indicating the specific deck locations where these actions should occur.

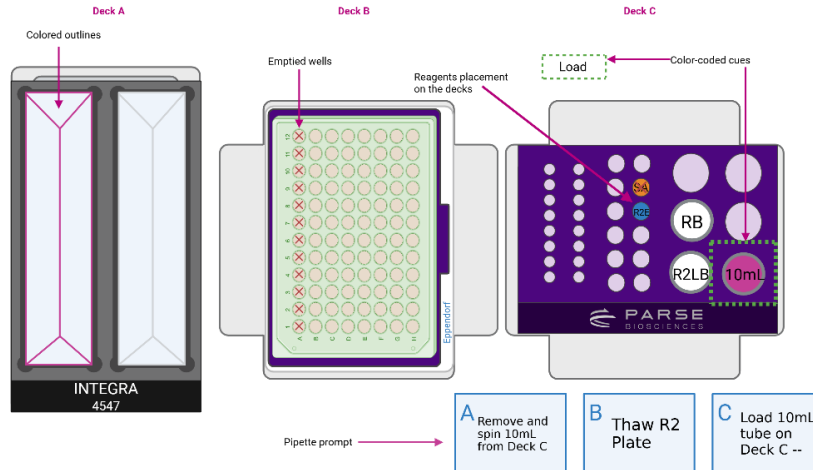

The Parse Metal Cold Block

It is critical to place reagents, samples, and consumables in the correct positions on the Parse Metal Cold Block.

The Parse Metal Cold Block is organized into three main columns, 1, 2 and 3, each containing two sub-columns (left and right) with slots of varying sizes to accommodate different tube types.

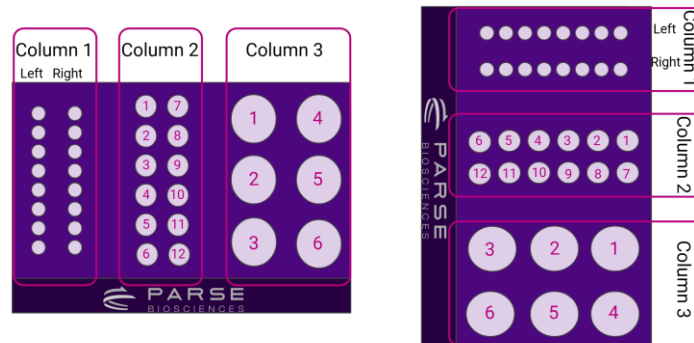

Color-Coded Cues

This workflow is semi-automated and still requires user interaction and input. Prompts will appear on the pipette display, instructing the user to perform tasks such as loading, moving,

removing, or replacing hardware, reagents, and consumables, as well as mixing and pipetting specific reagents. In this user guide, each prompt is color-coded and shown in the deck configurations illustrating the required actions. Additional explanatory text accompanies each figure to provide further detail on the steps involved.



- **Load:** Indicates labware and/or reagents that need be placed or reloaded onto the deck.
- **Remove:** Identifies labware that should be taken off the deck, either for incubation, disposal, or because it is not needed in the upcoming step.
- **Replace:** Highlights labware that has been used and needs to be swapped out for clean or new consumables.
- **Pipette:** Prompts the user to manually dispense reagents into designated basins.
- **Mix:** Instructs the user to mix specific reagents.
- **Move:** Indicates labware that should be relocated between deck positions.
- **X Emptied:** Reminds that the content has been used and the vessel is now empty.



Note: The position of the color-coded cues on top of the figures does not necessarily correspond to the location where the action should be taken.

Pipette Programs Diagram

At various points in the procedure, the user will need to switch pipettes and tip racks. In each subsection, the pipette is pre-programmed to carry out specific tasks defined by a designated script. The correct program must be loaded onto the pipette before beginning each set of steps. A diagram showing the path to load the appropriate program is provided in every subsection.

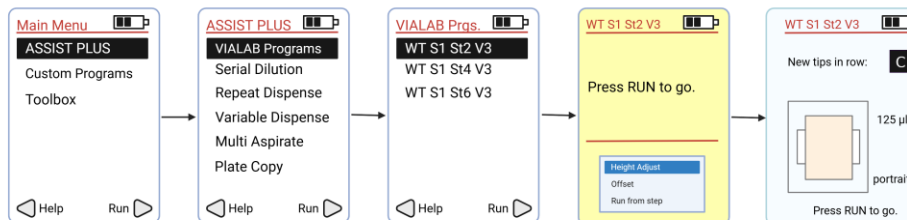

Section 1: Automation Setup & In Situ Barcoding

1.1. Sample Normalization

Prior to setting up the Automation workflow, count the cells/nuclei to assess quality and concentration of the fixed sample(s). Samples should be diluted with Sample Dilution Buffer to the target concentrations listed in the Sample Loading Table.

After adjusting the sample(s) to the recommended dilution range, update the Sample Loading Table, and download the Sample Loading Table macro (Section 1.1.4). This .csv file will be used as reference for allocating the fixed cells/nuclei into the 96-well PCR Dilution Plate, to prepare samples to be loaded into the Barcoding Round 1 Plate. The recommended dilution range for WT Mega is 2,125-8,000 cells/nuclei per μL .

The program uses the sample dilution buffer on Deck A to normalize fixed samples from plate format on Deck C into an intermediate dilution plate on Deck B.

1. Cool a centrifuge with swinging bucket rotors to 4°C
2. Set a water bath to 37°C.
3. Gather the following components and reagents:

ITEM	SOURCE	QTY	HANDLING AND STORAGE
D-ONE Pipetting Module 1-Ch, 5-1250 μL	INTEGRA Component	1	
Tip Deck for D-ONE Pipetting Module	INTEGRA Component	1	
125 μL Tip Rack	INTEGRA	1	
1250 μL Tip Rack	INTEGRA	1	
24 mm Labware Pedestal	INTEGRA Component	1	
Thermochromic PCR Cold Block	Parse	2	Pull the Thermochromic PCR Cold Block with riser from the -20°C freezer and leave them at room temperature for 10 minutes prior to use.
Thermochromic PCR Cold Block Riser	Parse	2	
Parse Metal Cold Block	Parse	1	Keep on ice when not in use.
Semi-Skirted 96 Well PCR Plate	Consumables	2	

ITEM	SOURCE	QTY	HANDLING AND STORAGE
● Sample Dilution Buffer	-20°C Reagents or ECAC3901	1	Thaw at room temperature then store on ice. Mix by inverting 3x.
Round 1 Plate	-20°C Reagents	1	Place directly on ice.

4. Download the Parse Biosciences Evercode WT INTEGRA Mega Sample Loading Table. The most current version of the Evercode WT INTEGRA Mega Sample Loading Table can be found on the Parse Biosciences [Customer Support Suite](#). Customer log-in is required to access the Sample Loading Table.
5. Thaw the previously fixed cells/nuclei samples in a water bath set to 37°C until all ice crystals dissolve. Thoroughly mix each sample by pipetting and store on ice.
6. If not done beforehand, count the number of cells/nuclei with an automated cell counter or alternative cell counting device. Record the cell/nuclei count. This will be used to fill out the Sample Loading Table in section 1.1.7d.
7. Fill the Sample Loading Table tab of the worksheet.
 - a. Per the instructions in the worksheet, input number of samples (Figure 1).



Note: For more information on using the Sample Loading Table, see the "Important Guidelines" section of the User Guide.

This sheet should be filled out prior to starting Section 1.

Step	Instructions
1	Ensure Macros are enabled.
2	Input the number of samples.
3	Input the target number of barcoded cells. Note: The default is 1,000,000 cells for Evercode WT Mega.
4	Input your sample names.
5	Input the target percentage representation of each sample in the final library. CRITICAL: No percentage can be lower than 1.05%. If not already done, count the samples as described in Section 1.1 of the Evercode WT Mega User Manual.
6	Input stock cell concentration for each sample.
7	Open the "Integra Loading Table" sheet and load the samples in the appropriate wells and volumes using a semi-skirted plate.
8	CRITICAL: Ensure that Sample Dilution Buffer is completely thawed before use.
9	Open the "Diluent Volumes" sheet. Click on the "Generate a Worklist for Import into VIALAB" to generate the worklist file.
10	Open the "Sample Volumes" sheet. Click on the "Generate a Worklist for Import into VIALAB" to generate the worklist file.

Number of Samples (Step 2):	<input type="text" value="3"/>	CRITICAL: We do not recommend editing cells highlighted in grey.
Target Number Barcoded Cells (Step 3):	<input type="text" value="1,000,000"/>	

Sample #	Sample Name (Step 4)	Percent of Library (Step 5)	Stock Concentration (cells/uL) (Step 6)	Number of Wells	Targeted Number of Barcoded Cells	Required Sample Concentration (cells/uL)
1	Sample A	40.00%	3,000	38	400000	2148
2	Sample B	35.00%	2,750	34	350000	2100
3	Sample C	25.00%	2,500	24	250000	2125
TOTALS:		100.00%		96	1,000,000	

Figure 1: Evercode WT Mega Sample Loading Table.

- b. Enter Target Number of Barcoded Cells, Sample Name, Percent of Library and Stock Concentration for corresponding samples. Errors and possible solutions can be found in Appendix C (Figure 2).



Note: If any parameter is out of range, the cells will turn pink in color and/or an error message will appear (Figure 2). Be sure to address and adjust worksheet input values appropriately before continuing.

This sheet should be filled out prior to starting Section 1.

Step	Instructions
1	Ensure Macros are enabled.
2	Input the number of samples.
3	Input the target number of barcoded cells. Note: The default is 100,000 cells for Evercode WT.
4	Input your sample names.
5	Input the target percentage representation of each sample in the final library. CRITICAL: No percentage can be lower than 2.09%. If not already done, count the samples as described in Section 1.1 of the Evercode WT User Manual.
6	Input stock cell concentration for each sample.
7	Prepare the dilutions as described. CRITICAL: Ensure that Sample Dilution Buffer is completely thawed before use.
8	Open the "Plate Configuration" sheet. With the plate on ice, add 14 μ L of each diluted sample to the appropriate well(s) of the Round 1 Plate as shown in the plate map. CRITICAL: Follow the instructions in the User Guide with respect to sample mixing and changing tips.

Number of Samples (Step 2): **CRITICAL:** We do not recommend editing cells highlighted in grey.

Target Number Barcoded Cells (Step 3):

Sample #	Sample Name (Step 4)	Percent of Library (Step 5)	Stock Concentration (cells/ μ L) (Step 6)	Number of Wells	Targeted Number of Barcoded Cells	Required Sample Concentration (cells/ μ L)
1		100.00%	5,000	48	1000000	5203
TOTALS:		100.00%		48	1,000,000	

CRITICAL: This cell stock concentration is too low.

Figure 2: Example error message, noting that the sample stock concentration is too low.

- c. Navigate to the "INTEGRA Loading Table" tab. If the "Required Number of Sample Dilution Tubes" is greater than 1, three additional dilution buffer tubes for highly concentrated samples can be purchased as a Sample Dilution Accessory Kit (see "Sample Concentrations" in Important Guidelines) (Figure 3).

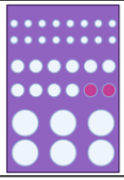

Note: Example: Sample 1 is loaded into Sample Location A1 and Sample Location A2 with a minimum volume of 131 μ L. More sample volume (up to a maximum of 200 μ L total sample volume) can be loaded to reduce bubbles during mixing.

Sample Name	Sample Location	Min Sample Stock Needed for Dilution (μ L)	*Note: due to semi-skirted plate volumes, multiple wells might be needed for the same samples.	Min Diluent Needed (μ L)	Required Number of Sample Dilution Tubes	Sample Dilution Tube Locations
Sample 1	A1	131.0		1955.0	2	
Sample 1	A2	131.0				
Sample 2	A3	84.0				
Sample 3	A4	84.0				
Sample 4	A5	84.0				
A6						
A7						
A8						
A9						
A10						
A11						
A12						
B1						
B2						

EXTRA SAMPLE DILUTION TUBES REQUIRED TO COMPLETE INTEGRA SAMPLE NORMALIZATION

Figure 3: INTEGRA Loading Table tab noting Minimum Diluent Needed and Sample Locations.

- d. Referring to the "INTEGRA Loading Table" tab, manually load fixed samples into the directed "Sample Location" well into a new Eppendorf semi-skirted plate. Note that any individual sample may require loading into more than one "Sample

Location" well. This is the sample stock plate. Store the sample stock plate on ice for later use.

- e. Navigate to the "Diluent Volumes" tab and click on the purple box labeled "Generate a Worklist for Import into VIALAB". Save the generated CSV file (called "CombinedMegaWorksheet_YYYYMMDD_HHMMSS.csv") for later use (Figure 4).

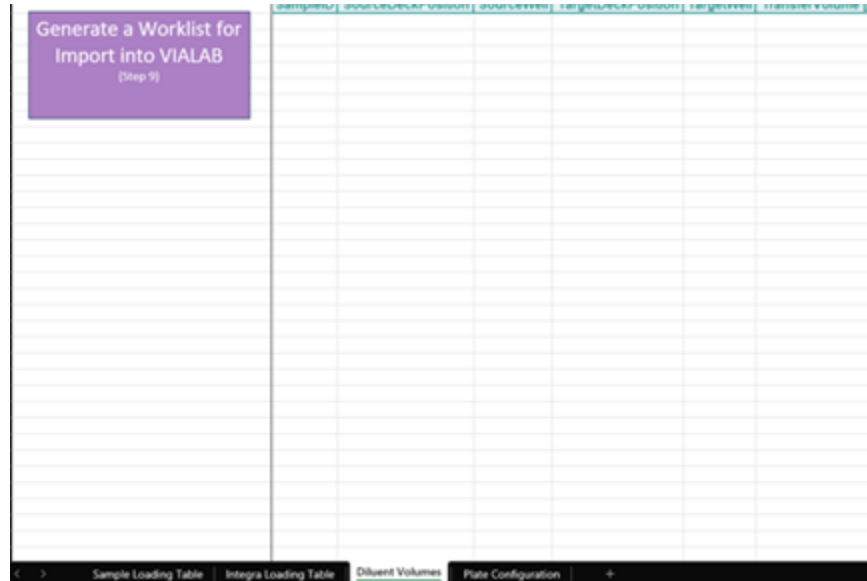

Figure 4: Diluent Buffer Volumes tab for generating a VIALAB worklist.

- f. Navigate to the "Plate Configuration" tab to visualize the final sample location within the 96 well plate format (Figure 5).

Evercode WT Round 1 Barcoding Plate Configuration

- For more details on using this Sample Loading Table, see the Important Guidelines section of the User Manual

Use the following plate layout to load samples into the Round 1 Plate in Section 1.2.

	1	2	3	4	5	6	7	8	9	10	11	12
A	1	1	1	1	1	1	1	1	1	1	1	1
B	1	1	1	1	1	1	1	1	1	1	1	1
C	2	2	2	2	2	2	2	2	2	2	2	2
D	2	2	2	2	2	2	2	2	2	2	2	2
E	3	3	3	3	3	3	3	3	3	3	3	3
F	3	3	3	3	3	3	3	3	3	3	3	3
G	4'	4'	4'	4'	4'	4'	4'	4'	4'	4'	4'	4'
H	4'	4'	4'	4'	4'	4'	4'	4'	4'	4'	4'	4'

Sample Number	Sample Name	Percent Contributing
1		100.00%

Figure 5: Plate Configuration tab visualizes the sample locations.

8. Import the generated CSV files into VIALAB to be uploaded on the pipettes.
 - a. Open the VIALAB program **MG S1 St1 DONE V3_5** and navigate to the "Method" section.



CRITICAL! Delete any previous S1 St1 scripts from the D-ONE pipette to avoid running incorrect scripts.

- b. In the "O2 Worklist", under the "Worklist and Volumes" tab, upload the "CombinedMegaWorksheet_YYYYMMDD_HHMMSS.csv" worklist file generated in Step 7e using the "Import" button (Figure 6).

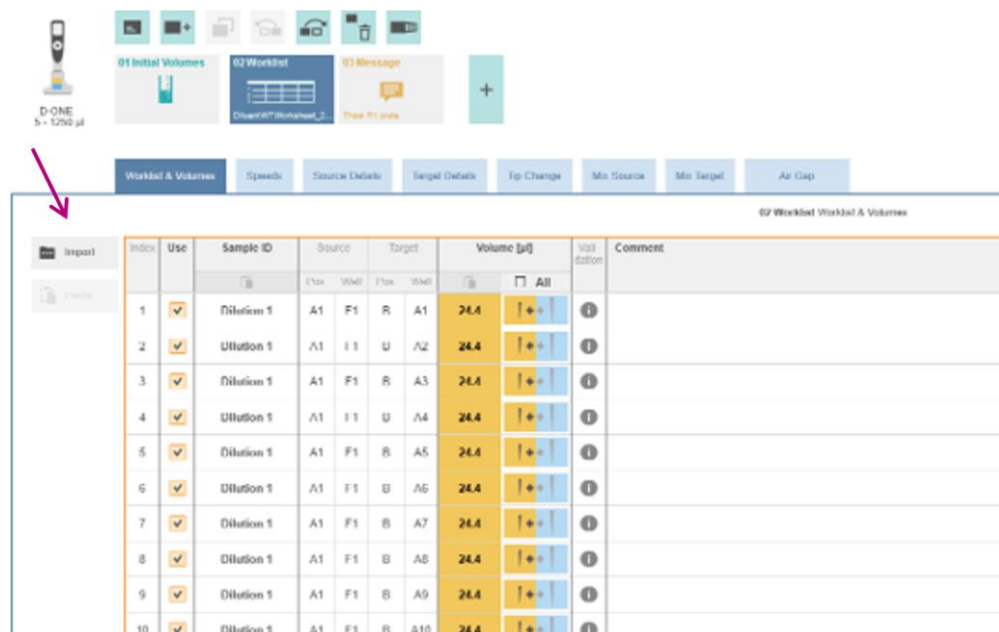

Index	Use	Sample ID	Source	Target	Volume [µl]	Validation	Comment
1	<input checked="" type="checkbox"/>	Dilution 1	A1 F1 R	A1	24.4	<input type="checkbox"/>	
2	<input checked="" type="checkbox"/>	Dilution 1	A1 F1 U	A2	24.4	<input type="checkbox"/>	
3	<input checked="" type="checkbox"/>	Dilution 1	A1 F1 R	A3	24.4	<input type="checkbox"/>	
4	<input checked="" type="checkbox"/>	Dilution 1	A1 F1 U	A4	24.4	<input type="checkbox"/>	
5	<input checked="" type="checkbox"/>	Dilution 1	A1 F1 R	A5	24.4	<input type="checkbox"/>	
6	<input checked="" type="checkbox"/>	Dilution 1	A1 F1 U	A6	24.4	<input type="checkbox"/>	
7	<input checked="" type="checkbox"/>	Dilution 1	A1 F1 R	A7	24.4	<input type="checkbox"/>	
8	<input checked="" type="checkbox"/>	Dilution 1	A1 F1 R	A8	24.4	<input type="checkbox"/>	
9	<input checked="" type="checkbox"/>	Dilution 1	A1 F1 R	A9	24.4	<input type="checkbox"/>	
10	<input checked="" type="checkbox"/>	Dilution 1	A1 F1 R	A10	24.4	<input type="checkbox"/>	

Figure 6: VIALAB worklist generation for diluent volumes using O2 Worklist.

9. Save and transfer your program to your D-ONE Pipetting Module (1-Ch, 5-1250 µL) as follows, ensuring that any program previously uploaded on the pipette is deleted:
 - a. Connect your computer with D-ONE Pipette using Communication/Charging Cable for VIAFLO.
 - b. Follow the instructions on the pipette menu, as shown in the diagram below:

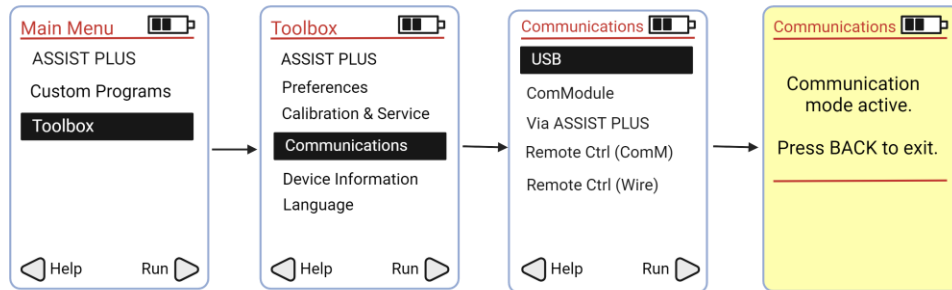

- c. Select the "Transfer" tab in the opened **MG S1 St1 DONE V3_5** VIALAB program.
- d. Confirm that the pipette has been recognized by the software. Click "Send to pipette". An audible signal will indicate the successful upload of the **MG S1 St1 V3_5** program to the D-ONE Pipette.
- e. Disconnect the cable and proceed with the protocol on the INTEGRA ASSIST PLUS platform.
- f. If done correctly, a program named **MG S1 St1 V3_5** will be found on your pipette as shown in the diagram below.

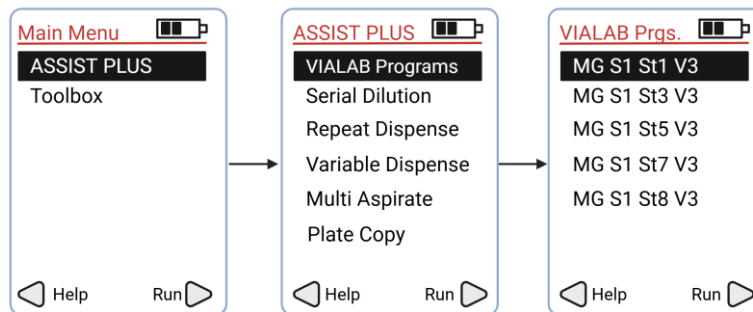

10. Set up the deck following the Deck Configuration below.

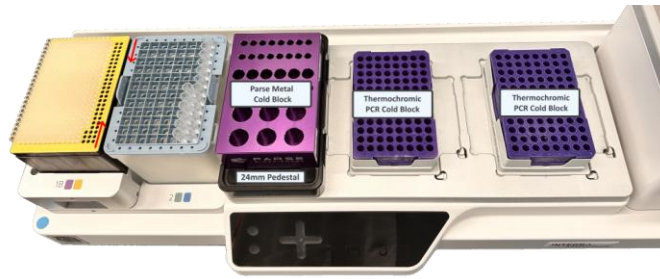

11. Load the following reagents and consumables to their respective positions on Decks A, B and C:

- a. Deck A, column 2
 - i. Pos 7: ● Sample Dilution Buffer.
- b. Deck B: a clean semi-skirted plate on Deck B with A1 corner in the bottom left.
- c. Deck C: Sample plate with A1 corner in the bottom left.

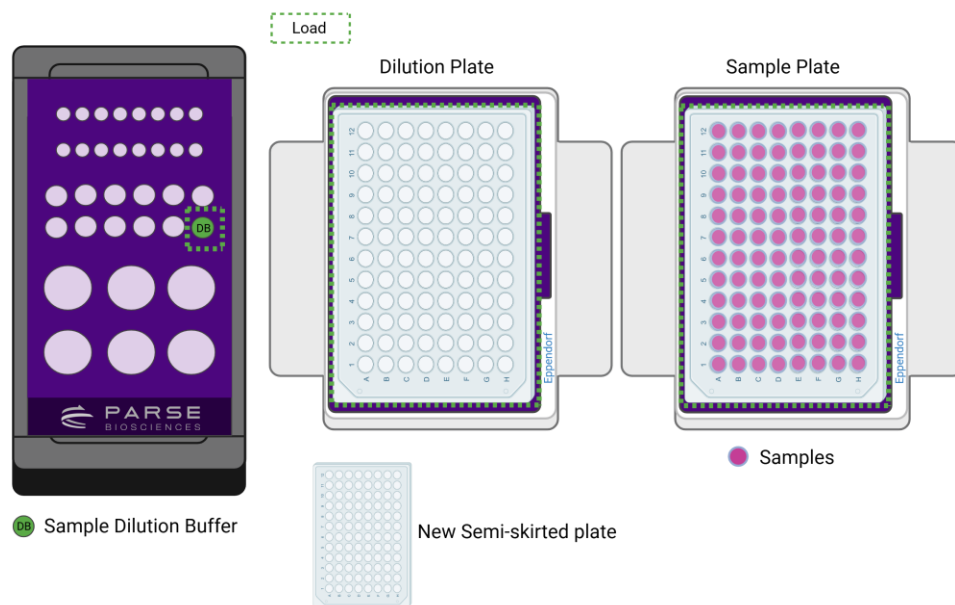

12. Attach D-ONE Pipetting Module 1-Ch, 5-1250 µL and the corresponding Tip Deck.

- a. Remove the reagent caps, then select and run the program **MG S1 St1 V3_5**. Ensure the Tip Deck and Tip Boxes are securely positioned by pressing them down firmly until they click into place.

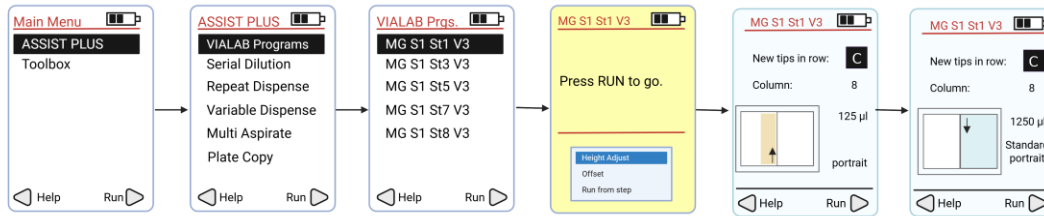

13. During the run, but after the ● Sample Dilution Buffer has been dispensed:

- a. Thaw the Round 1 Plate using the following thermocycling program. Remove a Thermochromic PCR Cold Block to thaw at room temperature during the following thermocycling program.

THAW ROUND 1 PLATE		
Run Time	Lid Temperature	Sample Volume
10 min	70°C	26 µL
Step	Time	Temperature
1	10 min	25°C
2	Hold	4°C

- b. At the completion of the thermocycler program, centrifuge the Round 1 Plate for **1 minute** at 100 x g at 4°C.

14. At the conclusion of the run:

- a. Store any remaining Sample Dilution Buffer from Deck A on ice. Remove all labware from Deck A.
- b. Keep all the labware, including the Diluted Sample Plate on Deck B. This will be used in the next step.
- c. Remove all the hardware on Deck C. Discard the used Sample Plate on Deck C.

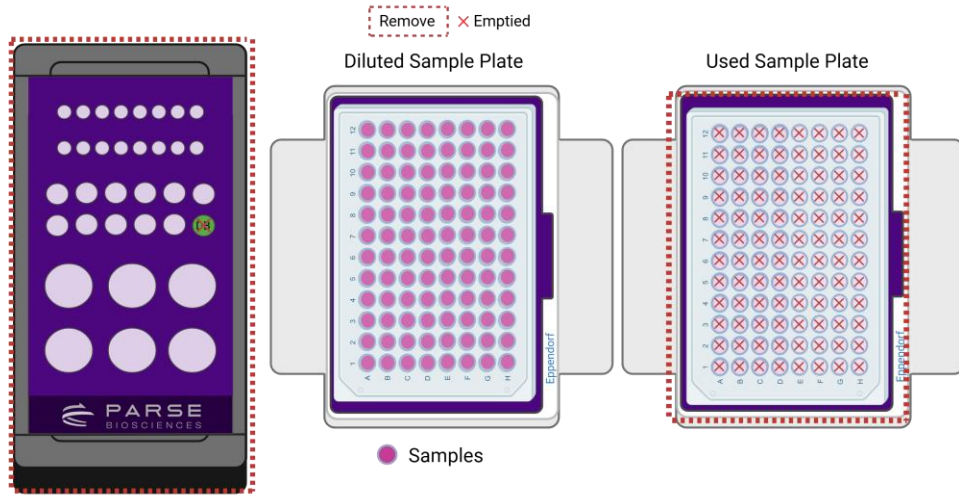

1.2. Load and Pool Round 1

The program loads the normalized cells/nuclei on Deck B into the Round 1 Plate on Deck C. After Barcoding Round 1 incubation, move the Round 1 Plate onto Deck B.

The program then pools all the samples in the Round 1 Plate into rows A and E.

To load the sample(s):

1. Gather the following components and reagents:

ITEM	SOURCE	QTY	HANDLING AND STORAGE
VIAFLO Pipette 12-Ch, 5-125 μ L	INTEGRA Component	1	
Tip Deck for VIAFLO Pipette 12-Ch, 5-125 μ L	INTEGRA Component	1	
5-125 μ L Tip Rack	INTEGRA	1	
Thermochromic PCR Cold Block	Parse	1	If not done earlier, pull the Thermochromic PCR Cold Block with riser from the -20°C freezer and leave them at room temperature for 10 minutes prior to use.
Thermochromic PCR Cold Block Riser	Parse	1	

2. Place the Thermochromic PCR Cold Block with Thermochromic PCR Cold Block Riser that was thawed during the previous step on Deck C following the configuration below.

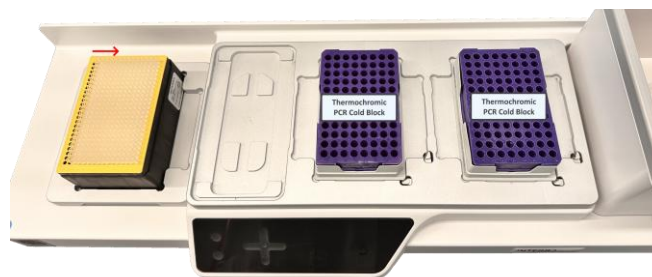

3. While secured in a PCR plate rack on a flat surface, remove the plate seal from the Round 1 Plate and place on Deck C with A1 at the bottom left. The diluted sample plate is still on Deck B with A1 at the bottom left.

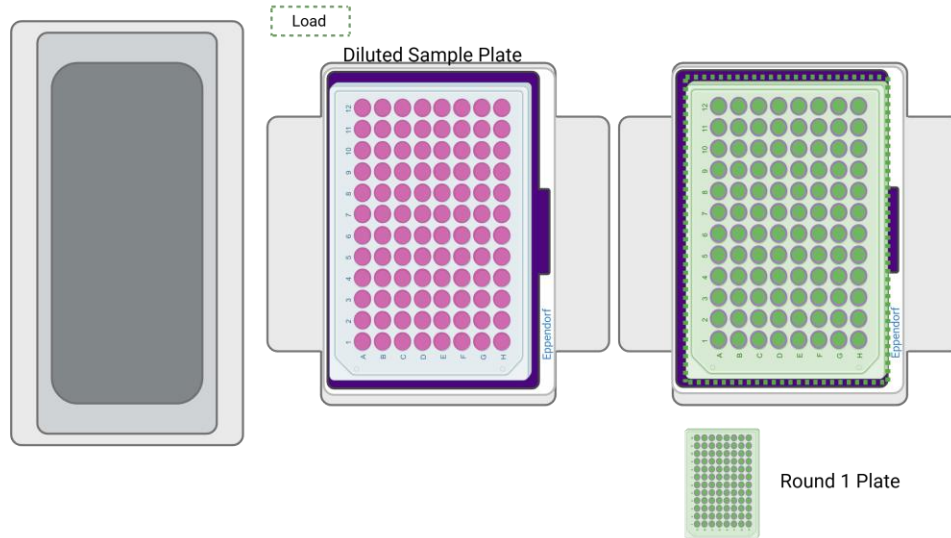

4. Change the pipette that is connected to the INTEGRA ASSIST PLUS:
 - a. Remove D-ONE Pipetting Module 1-Ch, 5-1250 μ L and corresponding Tip Deck. Ensure it is disconnected by pressing the back button until the main menu is displayed.
 - b. Replace it with VIAFLO 12-Ch 5-125 μ L Pipette and corresponding Tip Deck. Ensure the Tip Deck and Tip Box are securely positioned by pressing them down firmly until they click into place. Remove the tip box lid prior to starting the program.
5. Run the program **MG S1 St2 V3_5** following the diagram below.

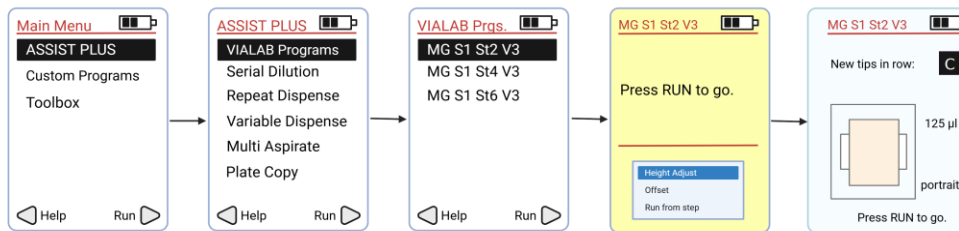

6. Press “Run” to continue the program. Follow the program prompts for manual intervention:

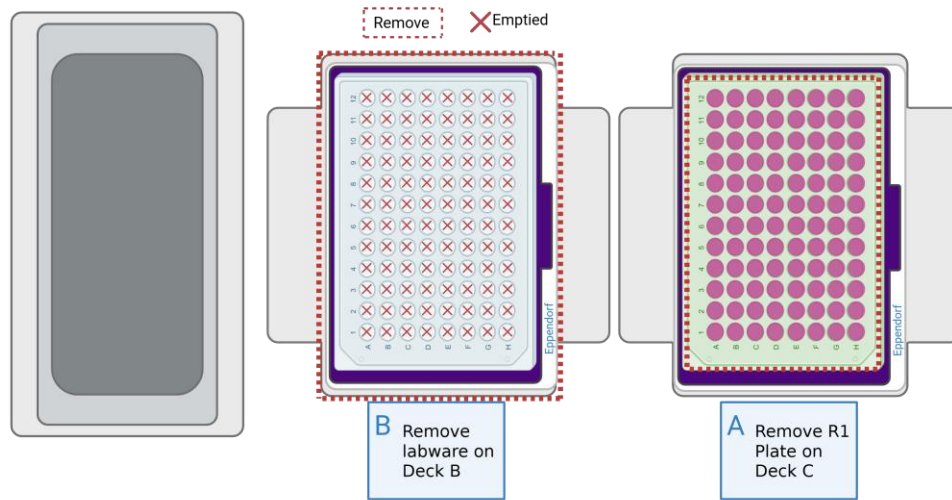

- a. Remove and seal the Round 1 Plate from Deck C using the Plate Seal Applicator. Place the Round 1 Plate into a thermocycler and run the following program.

BARCODING ROUND 1			
Run Time	Lid Temperature	Sample Volume	
40 min	70°C	40 µL	
Step	Time	Temperature	Cycles
1	10 min	50°C	1
2	12 s	8°C	3
3	45 s	15°C	
4	45 s	20°C	
5	30 s	30°C	
6	2 min	42°C	
7	3 min	50°C	1
8	5 min	50°C	
9	Hold	4°C	

- b. Remove and discard the now empty diluted sample plate on Deck B. Remove the Thermochromic PCR Cold Block located on Deck B and store it upside down in the freezer for future use.

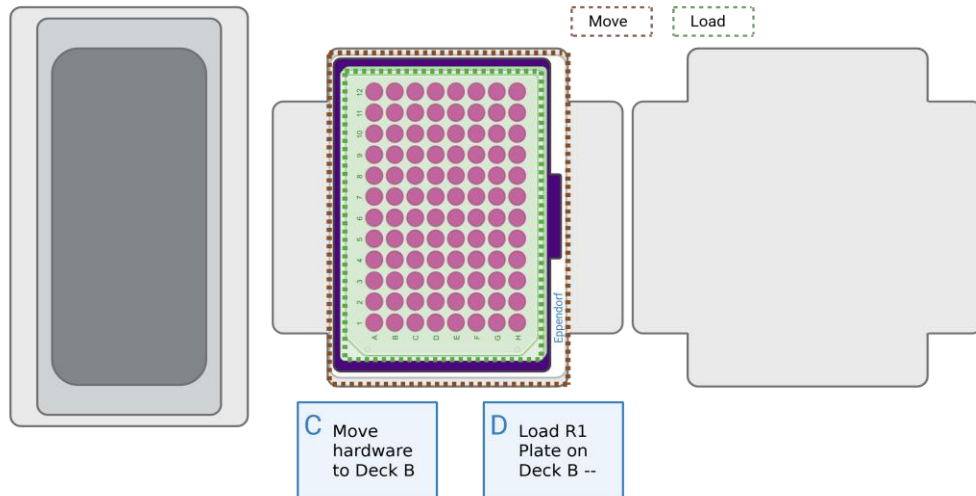

- c. Move the Thermochromic PCR Cold Block that was on Deck C to Deck B.
 - d. When the Barcoding Round 1 Thermocycling program is complete, load the Round 1 plate on the Thermochromic PCR Cold Block on Deck B. Press "Run" to continue the program.
7. At the conclusion of the run:
- a. The sample should be pooled into rows A and E of the Round 1 plate. Do not remove the labware on Deck B. This will be used in the next step.

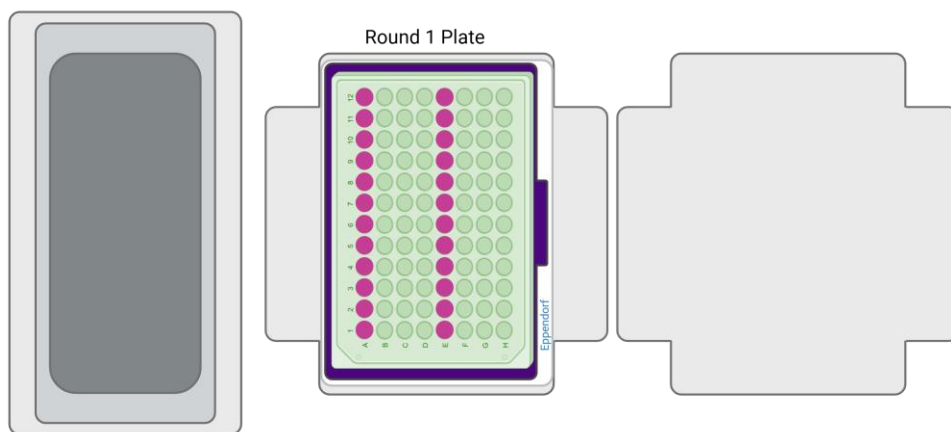

1.3. Round 2 Ligation Preparation

The program pools all the samples from the plate on Deck B into a 10 mL tube on Deck C. After centrifugation, the program removes supernatant and resuspends the cells in Resuspension Buffer. The program mixes Round 2 Ligation Enzyme and Round 2 Ligation Buffer with the resuspended cells. The cells are then put on the left basin on Deck A.

1. Gather the following components and reagents:

ITEM	SOURCE	QTY	HANDLING AND STORAGE
D-ONE Pipetting Module 1-Ch, 5-1250 µL	INTEGRA Components	1	
Thermochromic PCR Cold Block	Parse	1	Pull the Thermochromic PCR Cold Block with riser from the -20°C freezer and leave them at room temperature for 10 minutes prior to use.
Thermochromic PCR Cold Block Riser	Parse	1	
Parse Metal Cold Block	Parse	1	Keep on ice when not in use.
Tip Deck for D-ONE Pipetting Module	INTEGRA Components	1	
125 µL Tip Rack	INTEGRA	1	
1250 µL Tip Rack	INTEGRA	1	
10 mL transport tube	Consumables	1	
Dual Reservoir Adapter	INTEGRA Components	1	
25 mL Basin Reservoir Liners	INTEGRA	2	
Round 2 Plate	-20°C Reagents	1	Place directly on ice.
● Round 2 Ligation Enzyme	-20°C Reagents	1	Place directly on ice. Briefly centrifuge before use.
○ Round 2 Ligation Buffer	-20°C Reagents	1	Thaw at room temperature then store on ice. Mix by inverting 3x.
○ Resuspension Buffer	-20°C Reagents	1	
● Spin Additive	4°C Reagents	1	Briefly centrifuge. Keep at room temperature.
● Round 2 Stop Buffer	-20°C Reagents	1	Thaw at room temperature then store on ice until use in Section 1.4. Mix by vortexing before using.

2. Place the Dual Reservoir Adapter on Deck A.
3. Place the Parse Metal Cold Block on Deck C. The deck should correspond to the configuration below.

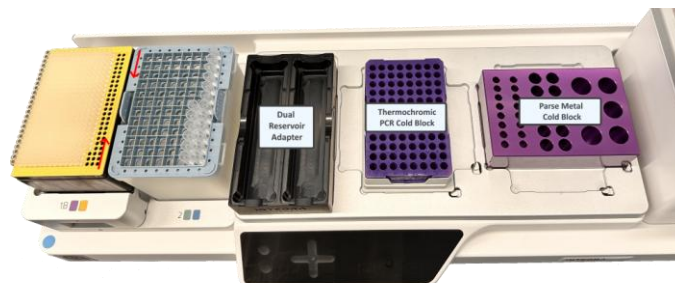

4. Load the following reagents and consumables to their respective positions on Deck A and on the Parse Metal Cold Block on Deck C.
 - a. On Deck A: two clean basin liners.
 - b. On Deck B: Round 1 Plate.
 - c. On Deck C, in the Parse Metal Cold Block:
 - i. Column 2:
 1. Pos 8: ● Spin Additive.
 2. Pos 9: ● Round 2 Ligation Enzyme.
 - ii. Column 3:
 1. Pos 2: ○ Resuspension Buffer.
 2. Pos 3: ○ Round 2 Ligation Buffer.
 3. Pos 6: a 10 mL transport tube.

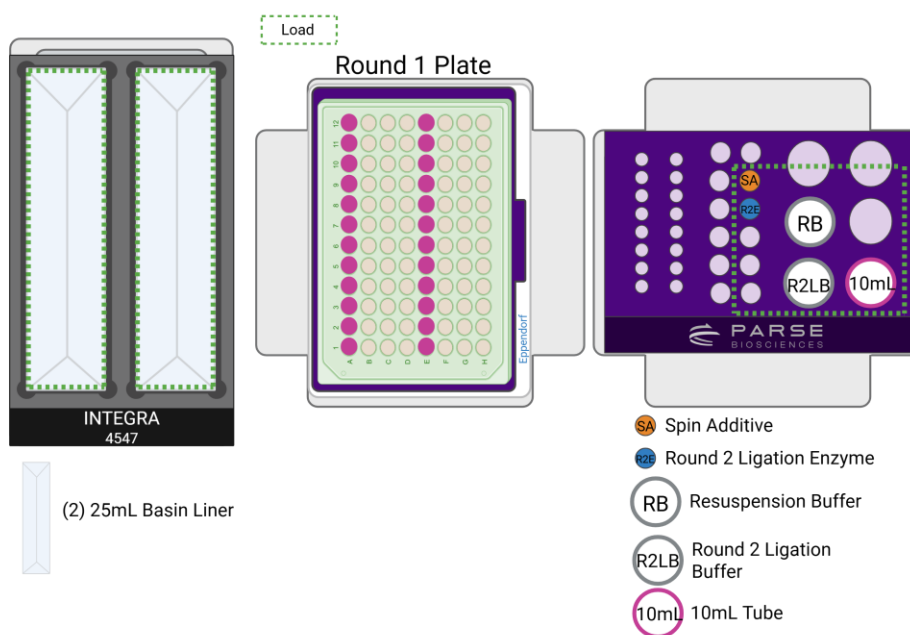

5. Change the pipette that is connected to the INTEGRA ASSIST PLUS:
 - a. Remove the VIAFLO 12-Ch 5-125 μ L pipette and corresponding tip deck. Ensure it is disconnected by pressing the back button until the main menu is displayed.
 - b. Replace it with the D-ONE Pipetting Module 1-Ch, 5-1250 μ L pipette and corresponding tip deck. Ensure the tip deck and tip boxes are securely positioned by pressing them down firmly until they click into place. Remove the tip box lids prior to starting the program.

6. Remove the reagent caps, then run the program **MG S1 St3 V3_5** following the diagram below.

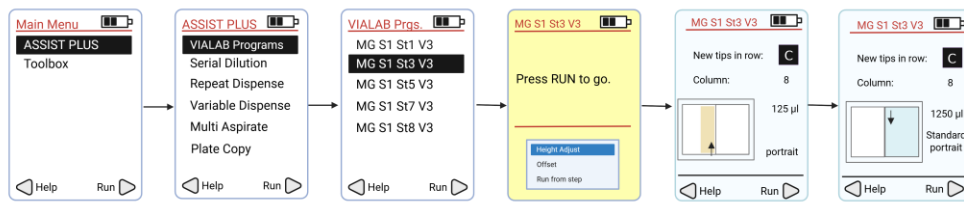

7. Press "Run" to continue the program. Follow the program prompts for manual intervention:

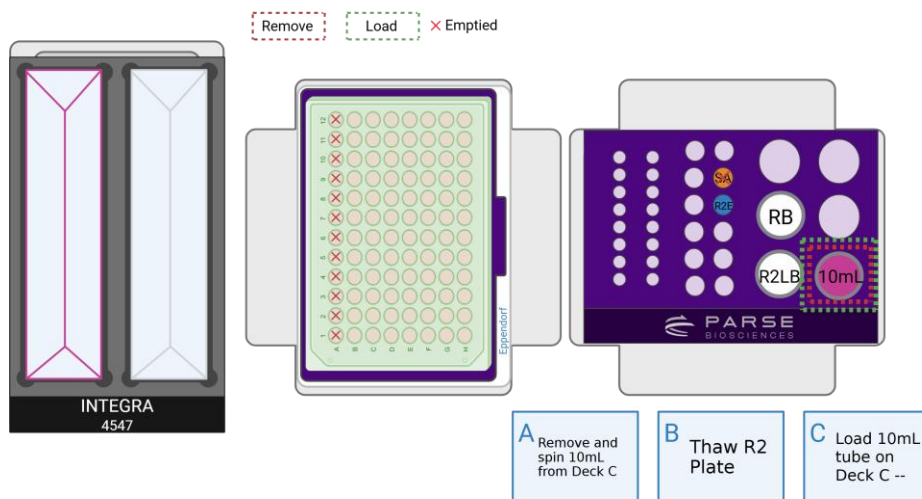

- Before removing for centrifugation, cap and invert once the 10 mL transport tube containing the pooled cells/nuclei in column 3, position 6. Centrifuge the sample in a swinging bucket centrifuge cooled to 4°C for **10 minutes** at 200-500 x g.
- Thaw the Round 2 Plate using the program below for later use. While the program is still running, remove a frozen Thermochromic PCR Cold Block with Riser from -20°C freezer and thaw at room temperature for later use.

THAW ROUND 2 PLATE		
Run Time	Lid Temperature	Sample Volume
10 min	70°C	10 µL
Step	Time	Temperature
1	10 min	25°C
2	Hold	4°C

- c. Once centrifugation is complete, remove the cap from the 10 mL transport tube and place it back in its original position within the Parse Metal Cold Block located on Deck C, position 6. Press "Run" to continue. The program will remove the supernatant, add the Resuspension Buffer, and the Round 2 Ligation Buffer.

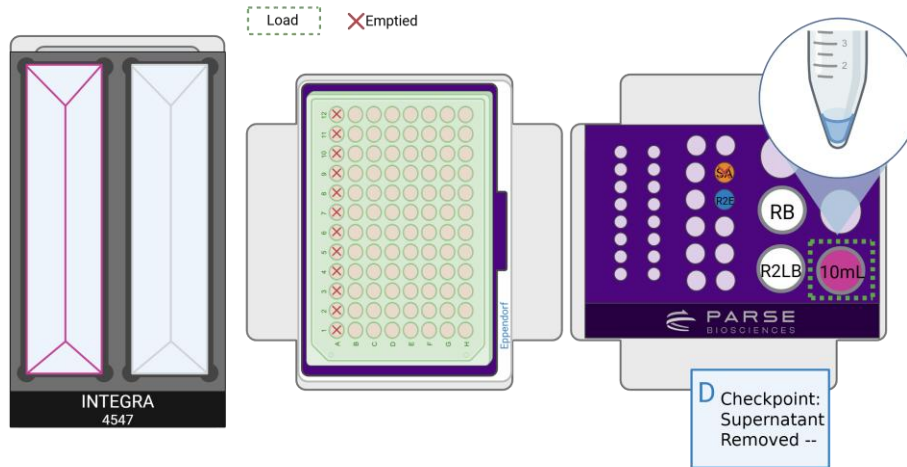

- d. Check the 10 mL tube after the supernatant removal steps. There should be remaining volume at the bottom of the 10 mL tube. The cell pellet may or may not be visible at this step.



CRITICAL! Return the 10 mL transport tube to the Parse Metal Cold Block immediately after centrifugation. Handle the tube with care to avoid jostling or disturbing the pellet. If the pellet becomes resuspended prior to supernatant removal, it may lead to loss of cells/nuclei.

8. At the conclusion of the run:
- a. Keep all the labware on Deck A. The sample is in the left basin liner on Deck A. Do not discard this. It will be used in the next step. Replace the right basin liner on Deck A with a clean 25 mL reservoir liner.
 - i. Remove all labware from Deck B. Discard the used Round 1 Plate. Remove the Thermochromic PCR Cold Block located on Deck B and store it in the freezer for future use.
 - j. Store the ● Spin Additive at room temperature. Do not discard it as it will be used for a future step. Discard other used tubes. Remove the hardware on Deck C.

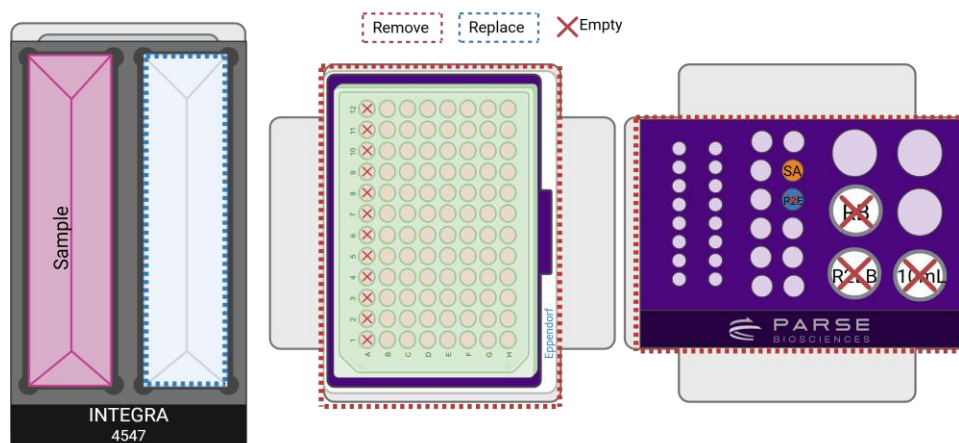

1.4. Round 2 Ligation

The program transfers the sample from the left reservoir on Deck A to Round 2 Plate on Deck B. Following Round 2 Incubation, the program will load Round 2 Stop Buffer in the right reservoir into each well. After Round 2 Stop incubation, it pools all samples together in the left reservoir on Deck A.

1. Gather the following items and handle as indicated below:

ITEM	SOURCE	QTY	HANDLING AND STORAGE
VIAFLO Pipette 12-Ch, 5-125 μ L	INTEGRA Components	1	
Tip Deck for VIAFLO Pipette 12-Ch, 5-125 μ L	INTEGRA Components	1	
125 μ L Tip Rack	INTEGRA	1	
Thermochromic PCR Cold Block	Parse	1	Pull the Thermochromic PCR Cold Block with riser from the -20°C freezer and leave them at room temperature for 10 minutes prior to use.
Thermochromic PCR Cold Block Riser	Parse	1	
INTEGRA Dual 25mL Basin Reservoir Adapter	INTEGRA	1	
25 mL Basin Reservoir Liners	INTEGRA	2	

2. Place the Thermochromic PCR Cold Block with Thermochromic PCR Cold Block Riser removed from the freezer in step 1.3.7b on Deck B.

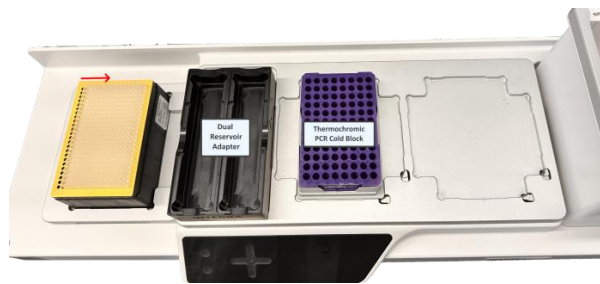

3. While secured in a PCR plate rack on a flat surface, remove the plate seal from the Round 2 Plate and place on Deck B with A1 at the bottom left.

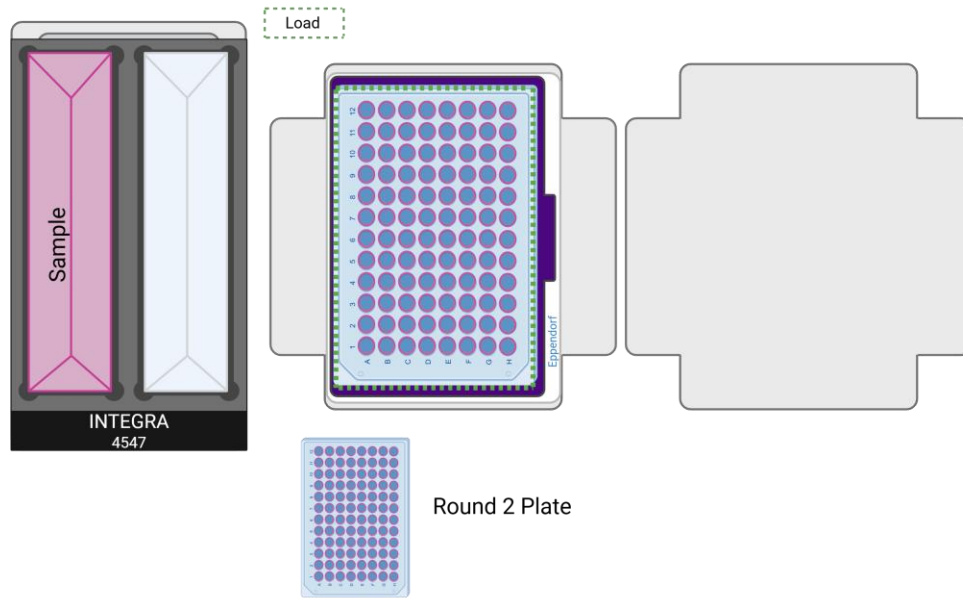

4. Change the pipette that is connected to the INTEGRA ASSIST PLUS:
 - a. Remove the D-ONE Pipetting Module 1-Ch, 5-1250 μ L pipette and corresponding tip deck. Ensure it is disconnected by pressing the back button until the main menu is displayed.
 - b. Replace it with the VIAFLO 12-Ch 5-125 μ L pipette and corresponding tip deck. Ensure the tip deck and tip box are securely positioned by pressing them down firmly until they click into place. Remove the tip box lid prior to starting the program.
5. Run the program **MG S1 St4 V3_5** following the diagram below.

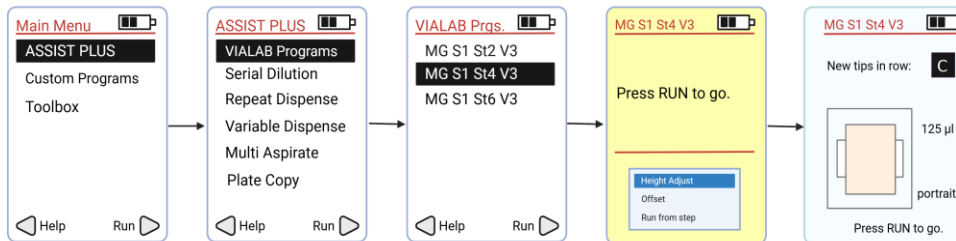

6. Press “Run” on the program to continue. Follow the program prompts for manual intervention:

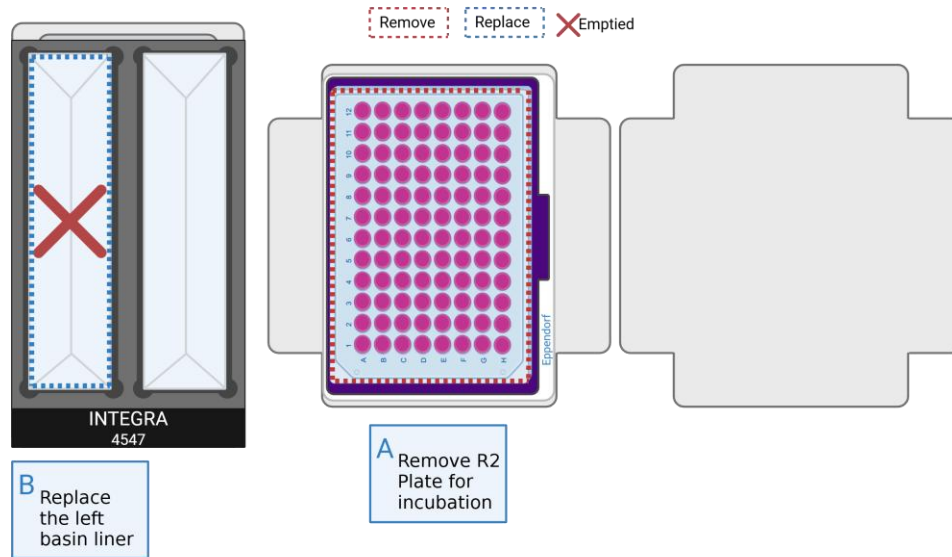

Note: If the volume is still insufficient to fill every well, a few can be left empty without impacting experimental results.

a. Remove the Round 2 Plate from Deck B. Reseal the Round 2 Plate with an adhesive seal, place it into a thermocycler, and run the following program.

BARCODING ROUND 2		
Run Time	Lid Temperature	Sample Volume
15 min	50°C	50 µL
Step	Time	Temperature
1	15 min	16°C
2	Hold	4°C

b. Replace the used left basin liner with a clean 25 mL basin reservoir liner.

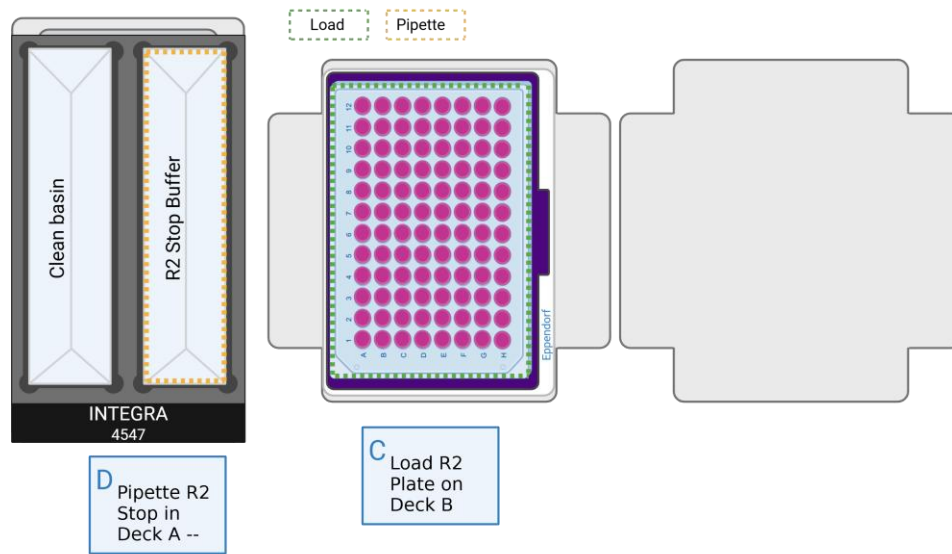

- c. When the Barcoding Round 2 Thermocycling program is complete, load the Round 2 Plate on the Thermochromic PCR Cold Block on Deck B with A1 oriented towards the lower left corner.
 - d. Briefly vortex (2-3 seconds) and centrifuge the ● Round 2 Stop Buffer. Pipette the total volume (~1.4 mL) to the right basin on Deck A with a P1000 set to 1000 μ L. Disperse the liquid to ensure it is even across the basin.
7. Press "Run" to continue the program. Follow the program prompts to complete the program:

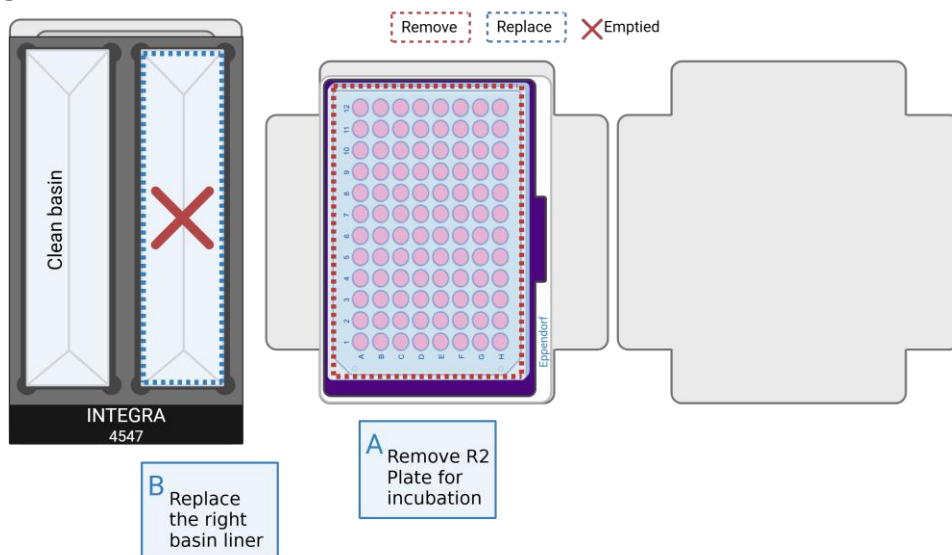

- a. Remove the Round 2 Plate from Deck B. Reseal the Round 2 Plate with an adhesive seal, and incubate the Round 2 Plate in a thermocycler using the following protocol.

ROUND 2 STOP		
Run Time	Lid Temperature	Sample Volume
5 min	50°C	60 µL
Step	Time	Temperature
1	5 min	16°C
2	Hold	4°C

- b. Replace the used right basin liner with a clean 25 mL basin reservoir liner.

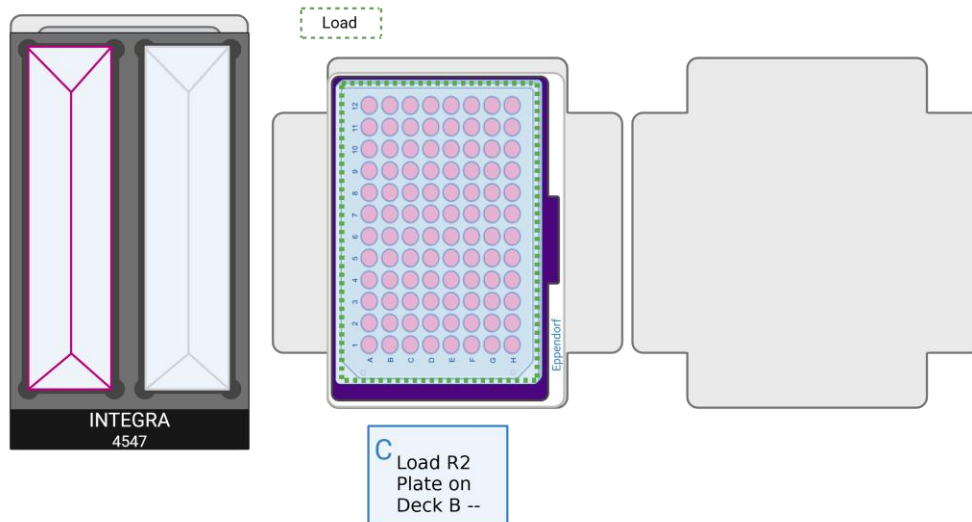

- c. When the Barcoding Round 2 Stop Thermocycling program is complete, load the Round 2 plate on the Thermochromic PCR Cold Block on Deck B with A1 oriented towards the lower left corner. Remove the plate seal before continuing the program.
8. At the completion of the run:
- Keep all the labware on Deck A. The sample is in the left basin liner on Deck A. Do not discard this. It will be used in the next step.
 - Remove all labware from Deck B. Discard the used Round 2 Plate. Remove the Thermochromic PCR Cold Block located on Deck B and store it upside down in the freezer.

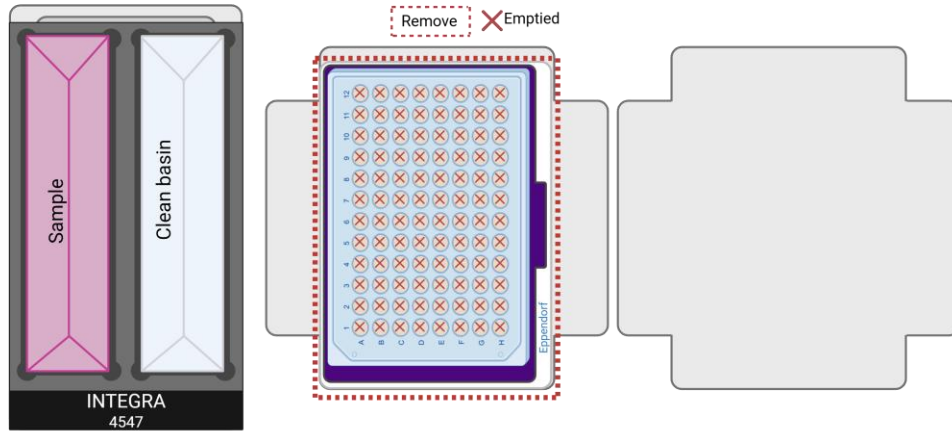

1.5. Round 3 Ligation Preparation

The pooled cell suspension in the left reservoir on Deck A is strained into the 10 mL transport tube on Deck C. The program adds Round 3 Ligation Enzyme into the cells and mixes. It then transfers the cell/nuclei suspension mix to the top reservoir within the slanted plate holder on Deck B.

1. Gather the following components and reagents:

ITEM	SOURCE	QTY	HANDLING AND STORAGE
D-ONE Pipetting Module 1-Ch, 5-1250 μ L	INTEGRA Component	1	
Tip Deck for D-ONE Pipetting Module	INTEGRA Component	1	
Parse Metal Cold Block	Parse-Provided	1	Keep on ice when not in use.
Dual Reservoir Adapter (ANSI/SLAS footprint)	INTEGRA Component	1	
ASSIST PLUS Slanted Plate Holder	INTEGRA Component	1	
10 mL transport tube	Consumables	1	
25 mL Basin Reservoir Liners	INTEGRA	2	
25 μ m, 40 μ m, or 70 μ m cell strainer	Consumables	1	
125 μ L Tip Rack	INTEGRA	1	
1250 μ L Tip Rack	INTEGRA	1	
Round 3 Plate	-20°C Reagents	1	Place directly on ice.
● Round 3 Ligation Enzyme	-20°C Reagents	1	Place directly on ice. Briefly centrifuge before use.

2. Place the Parse Metal Cold Block on Deck C.

2. Place the ASSIST PLUS Slanted Plate Holder set to 10° on Deck B. The lower end should be on the left. Deck layout should correspond to the configuration below.

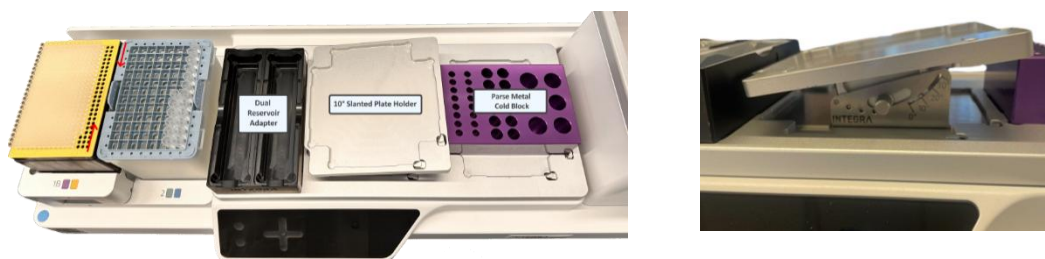

4. Load the following reagents to their respective positions on the Parse Metal Cold Block on Deck C.
 - a. Column 2:
 - i. pos 10: ● Round 3 Ligation Enzyme.
 - b. Column 3:
 - i. pos 6: a clean 10 mL transportation tube.

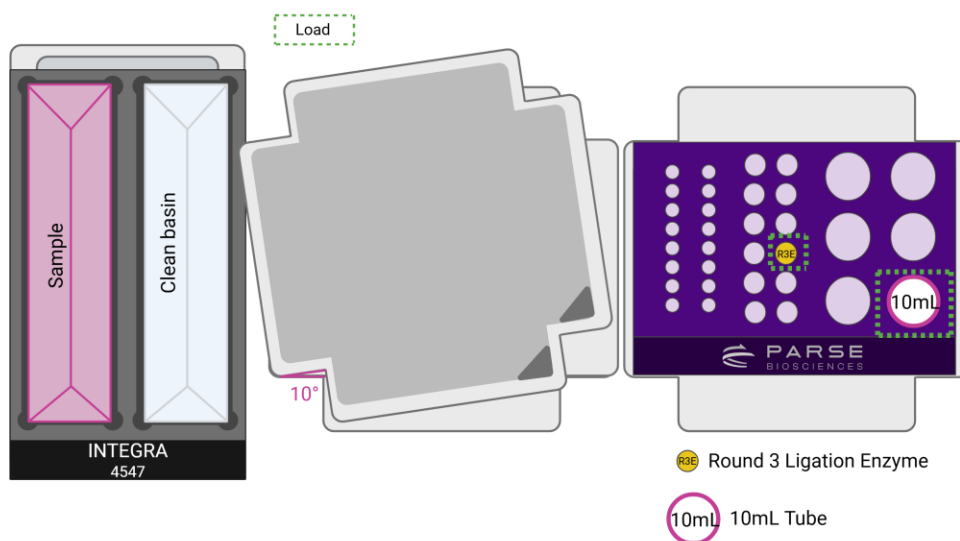

5. Change the pipette that is connected to the INTEGRA ASSIST PLUS:
 - a. Remove the VIAFLO 12-Ch 5-125 μ L pipette and corresponding tip deck. Ensure it is disconnected by pressing the back button until the main menu is displayed.
 - b. Replace it with the D-ONE Pipetting Module 1-Ch, 5-1250 μ L pipette and corresponding tip deck. Ensure the tip deck and tip boxes are securely positioned by pressing them down firmly until they click into place. Remove the tip box lids prior to starting the program.

- Remove the reagent caps, then select and run the program **MG S1 St5 V3_5** following the diagram below.

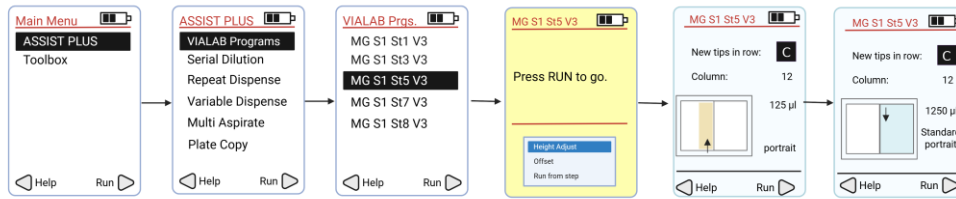

- Press "Run" to continue the program. Follow the program prompts for manual intervention to move the basin as indicated below:

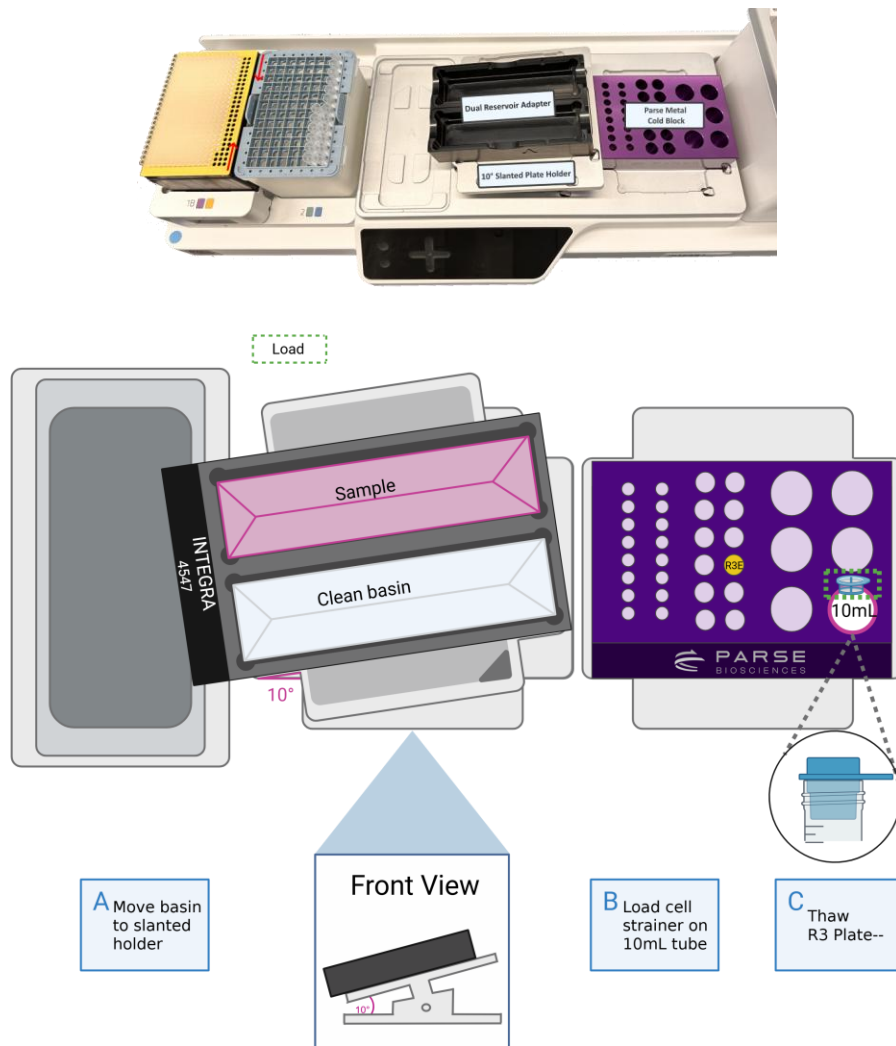

Note: When moving the dual reservoir adapter onto the slanted plate holder on Deck B, take extra care when moving the sample to avoid spills.

- a. Move the Dual Reservoir Adapter with the sample from Deck A to the slanted plate holder on Deck B. The INTEGRA logo at the front of the Dual Reservoir Adapter faces towards the pipette tip box. The sample should now be located on the top reservoir of the Dual Reservoir Adapter.
- b. Load a cell strainer so it sits inside of the 10 mL transport tube.
- c. Thaw the Parse Round 3 Plate using the program below for later use. While the thermocycling program is running, remove a new ThermoChromic PCR Cold Block with Riser from -20°C freezer and thaw at room temperature and continue to the next step.

THAW ROUND 3 PLATE		
Run Time	Lid Temperature	Sample Volume
10 min	70°C	10 µL
Step	Time	Temperature
1	10 min	25°C
2	Hold	4°C

8. Press "Run" to continue the program. Follow the program prompts to complete the program:

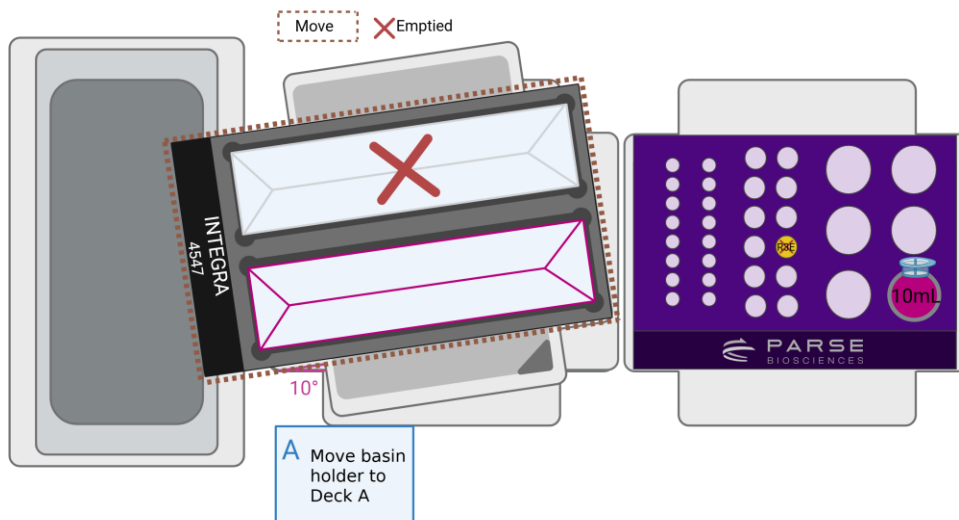

- a. Move the Dual Reservoir adapter to Deck A. Ensure that the INTEGRA logo is facing the front.

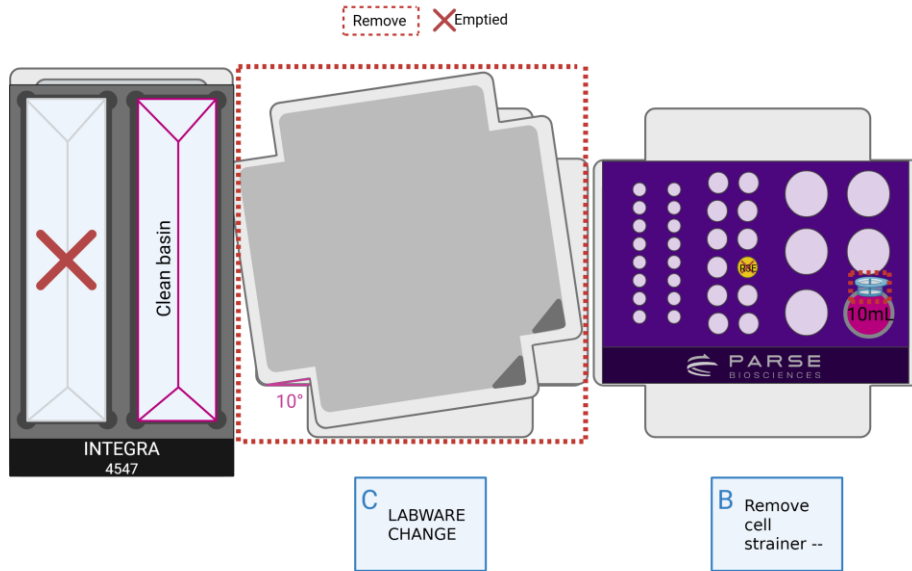

- b. Remove the used cell strainer from the 10 mL transport tube on Deck C.



Note: There may be bubbles left on the strainer. This will not affect the results.

- c. Remove Slanted Plate Holder from Deck B.
9. Press "Run" to continue the program. At the completion of the run:
 - a. Keep all labware on Deck A. The sample is in the right basin liner on Deck A. Do not discard this. It will be used in the next step.
 - b. Remove all labware from Deck C. Discard all used tubes on Deck C.

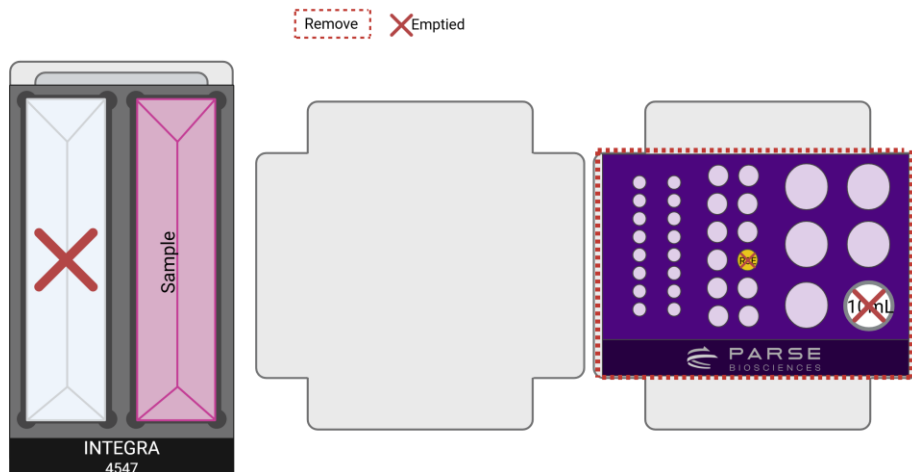

1.6. Round 3 Ligation

The program loads the Cell Suspension Mix on Deck A into the Round 3 Plate on Deck B. Following the prompts for Round 3 incubation, the program will then load Round 3 Stop Buffer into all the wells and pool all the samples together on Deck A.

1. Gather the following components and reagents:

ITEM	SOURCE	QTY	HANDLING AND STORAGE
VIAFLO Pipette 12-Ch, 5-125 μ L	INTEGRA Component	1	
Tip Deck for VIAFLO Pipette 12-Ch, 5-125 μ L	INTEGRA Component	1	
Thermochromic PCR Cold Block	Parse	1	Pull the Thermochromic PCR Cold Block with riser from the -20°C freezer and leave them at room temperature for 10 minutes prior to use.
Thermochromic PCR Cold Block Riser	Parse	1	
INTEGRA Dual 25mL Basin Reservoir Adapter	INTEGRA Component	1	
25 mL Basin Reservoir Liners	INTEGRA	2	
25 μ m, 40 μ m, or 70 μ m cell strainer	Consumables	1	
125 μ L Tip Rack	INTEGRA	1	
○ Round 3 Stop Buffer	-20°C Reagents	1	Thaw at room temperature then store on ice. Mix by vortexing.

2. Place the Thermochromic PCR Cold Block with Riser removed from the freezer in step 1.5.7c on Deck B. Deck layout should correspond to the configuration below.



3. While secured in a PCR plate rack on a flat surface, remove the plate seal from the Round 3 Plate and place on Deck B with A1 at the bottom left.

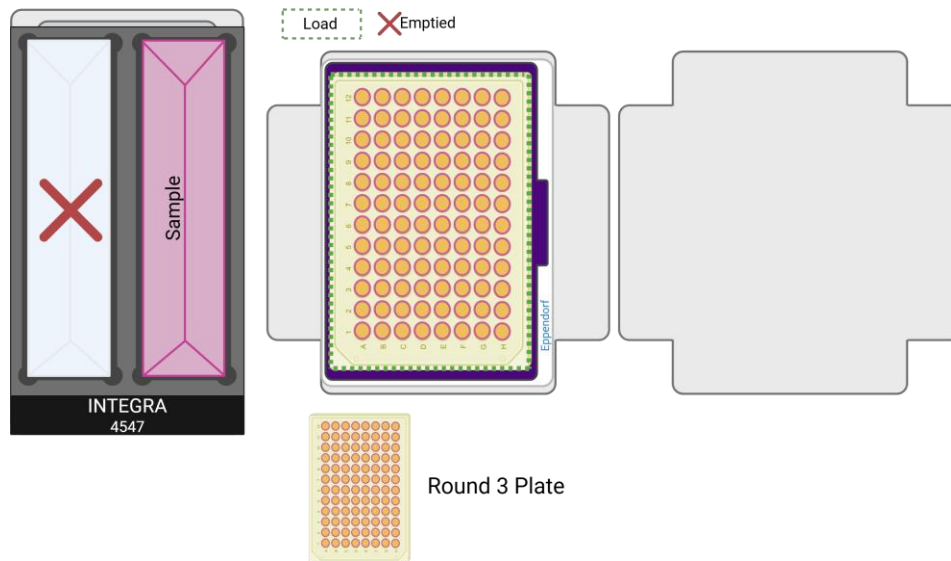

4. Change the pipette that is connected to the INTEGRA ASSIST PLUS:
 - a. Remove the D-ONE Pipetting Module 1-Ch, 5-1250 μL pipette and corresponding tip deck. Ensure it is disconnected by pressing the back button until the main menu is displayed.
 - b. Replace it with the VIAFLO 12-Ch 5-125 μL pipette and corresponding tip deck. Ensure the tip deck and tip box are securely positioned by pressing them down firmly until they click into place. Remove the tip box lid prior to starting the program.
5. Run the program **MG S1 St6 V3_5** following the diagram below.

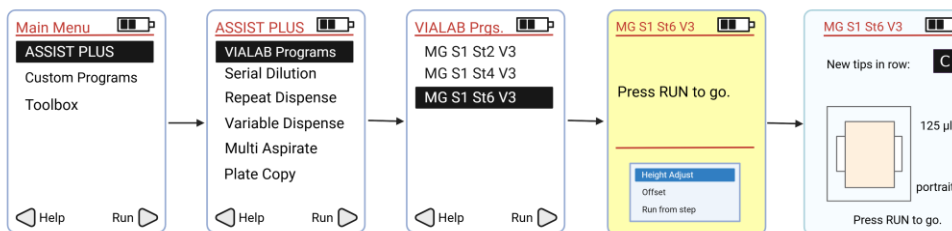

6. Press “Run” to continue the program. Follow the program prompts for manual intervention:

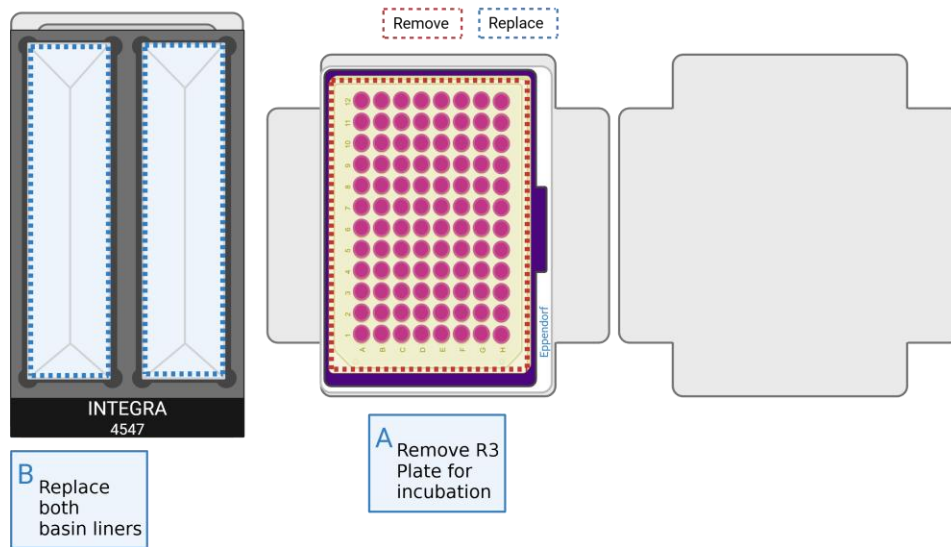

a. Remove the Round 3 Plate from Deck B. Reseal the Round 3 Plate with an adhesive seal, place it into a thermocycler, and run the following program.

BARCODING ROUND 3		
Run Time	Lid Temperature	Sample Volume
15 min	50°C	60 µL
Step	Time	Temperature
1	15 min	16°C
2	Hold	4°C

b. Replace both used basin liners on Deck A with clean 25 mL basin reservoir liners.

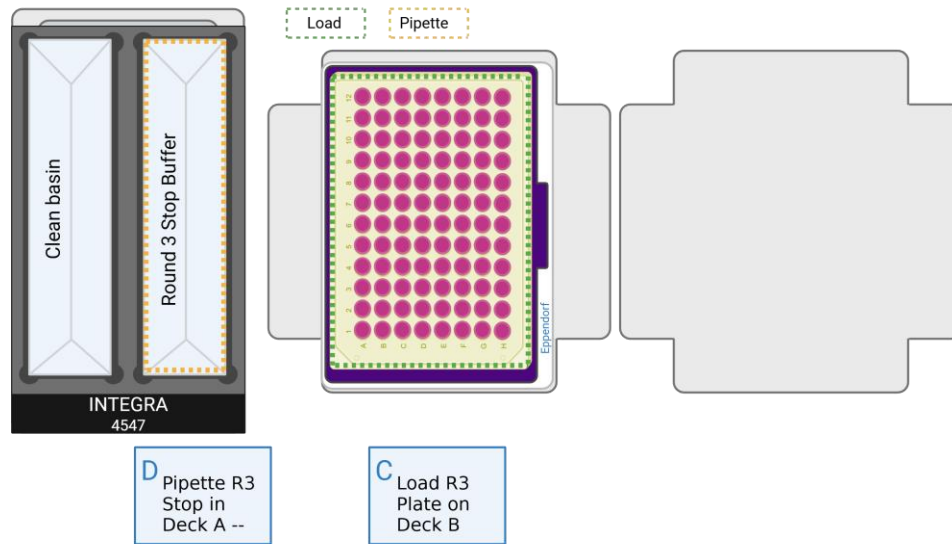

- c. When the Barcoding Round 3 Thermocycling program is complete, load the Round 3 plate on the Thermochromic PCR Cold Block on Deck B with A1 oriented towards the lower left corner.
- d. Briefly vortex (2-3 seconds) the  Round 3 Stop Buffer and ensure there is no precipitate. Pipette the total volume (~3.5 mL) to the right basin on Deck A using a P1000 set to 1000 μ L.

7. At the completion of the run:

- a. Keep all the labware on Deck A. The sample is in the left basin liner on Deck A. Do not discard this. It will be used in the next step.
- b. Remove all labware from Deck B. Discard the used Round 3 Plate. Remove the Thermochromic PCR Cold Block located on Deck B and store it in the freezer.

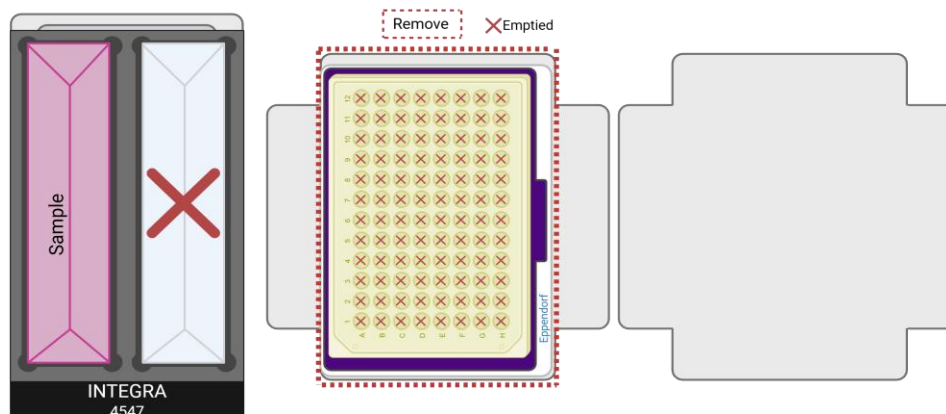

1.7. Pre-Lysis

The pooled cell suspension on Deck B is strained into the 10 mL transport tube on Deck C. The Spin Additive is then added into the cells and centrifuged. Supernatant is removed; the cells are resuspended in Pre Lysis Wash Buffer, and centrifuged again. The supernatant is then removed.

1. Gather the following components and reagents:

ITEM	SOURCE	QTY	HANDLING AND STORAGE
D-ONE Pipetting Module 1-Ch, 5-1250 µL	INTEGRA Components	1	
Tip Deck for D-ONE Pipetting Module	INTEGRA Components	1	
Parse Metal Cold Block	Parse	1	Keep on ice when not in use.
ASSIST PLUS Slanted Plate Holder	INTEGRA Components	1	
Dual 25mL Basin Reservoir Adapter	INTEGRA Components	1	
10 mL transport tube	Consumables	1	
25 mL basin reservoir liners	INTEGRA	2	
25 µm, 40 µm, or 70 µm cell strainer	Consumables	1	
125 µL Tip Rack	INTEGRA	1	
1250 µL Tip Rack	INTEGRA	1	
● Spin Additive	4°C Reagents	1	Keep at room temperature.
○ Pre-Lysis Wash Buffer	-20°C Reagents	1	Thaw at room temperature then store on ice. Mix by pipetting 3x.
● Pre-Lysis Dilution Buffer	-20°C Reagents	1	Thaw at room temperature then store on ice until use in Section 1.8. Pipette mix 3x before use.

2. Place the Parse Metal Cold Block on Deck C.

3. Place the ASSIST PLUS Slanted Plate Holder set to 10° on Deck B. The lower end should be on the left. Deck layout should correspond to the configuration below.

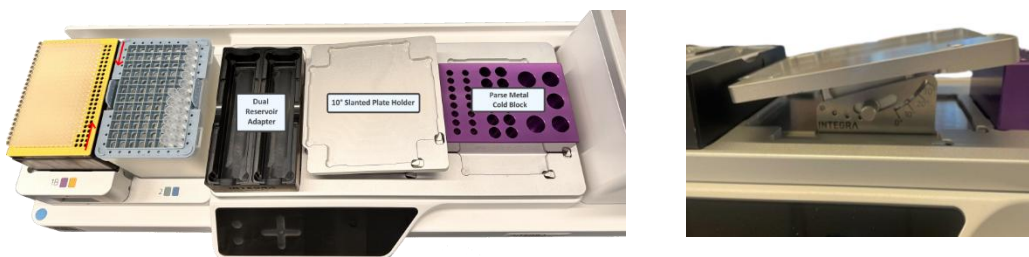

4. Change the pipette that is connected to the INTEGRA ASSIST PLUS:
 - a. Remove the VIAFLO 12-Ch 5-125 μ L pipette and corresponding tip deck. Ensure it is disconnected by pressing the back button until the main menu is displayed.
 - b. Replace it with the D-ONE Pipetting Module 1-Ch, 5-1250 μ L pipette and corresponding tip deck. Ensure the tip deck and tip boxes are securely positioned by pressing them down firmly until they click into place. Remove the tip box lids prior to starting the program.

5. Load the following reagents to their respective positions on the Parse Metal Cold Block on Deck C.
 - a. Column 2:
 - i. Pos 8: ● Spin Additive.
 - b. Column 3:
 - i. Pos 1: ○ Pre-Lysis Wash Buffer.
 - ii. Pos 6: a clean 10 mL transport tube.

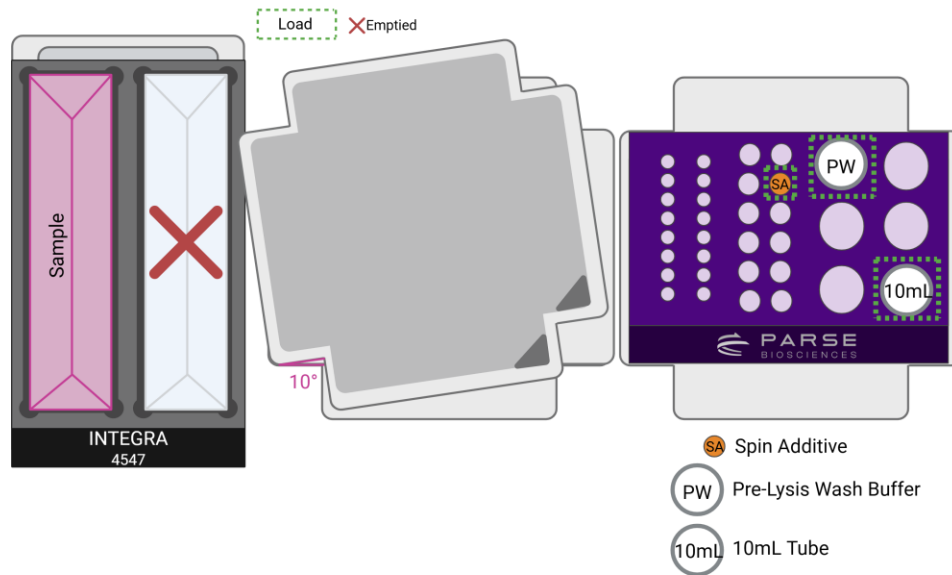

6. Remove reagent caps, select and run the program **MG S1 St7 V3_5** following the diagram below.

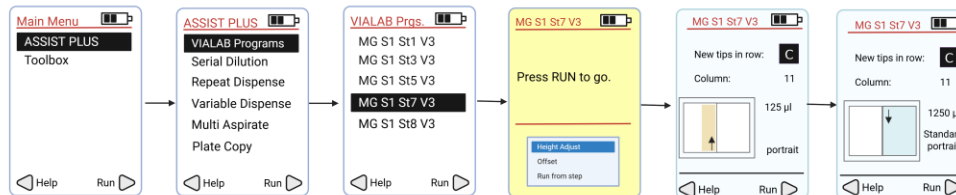

7. Press “Run” to continue the program. Follow the program prompts for manual intervention:

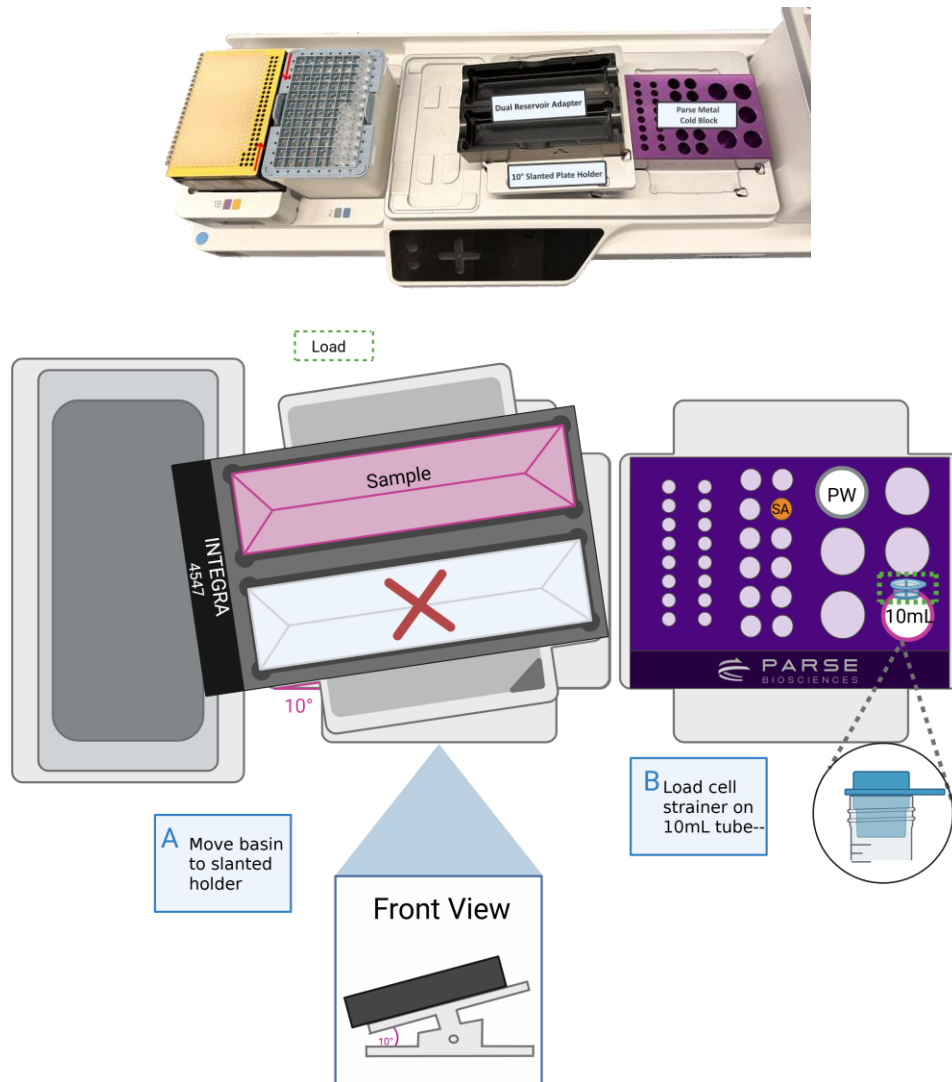

- a. Move the Dual Reservoir Adapter with the sample from Deck A to the slanted plate holder on Deck B. The INTEGRA logo at the front of the Dual Reservoir Adapter faces towards the pipette tip box. The sample should now be located on the top reservoir of the Dual Reservoir Adapter.



Note: When moving the dual reservoir adapter onto the slanted plate holder on Deck B, use extra care when moving the sample to avoid spills.

- b. Load a cell strainer so it sits inside of the 10 mL transport tube.

8. Press “Run” to continue the program. Follow the program prompts for manual intervention:

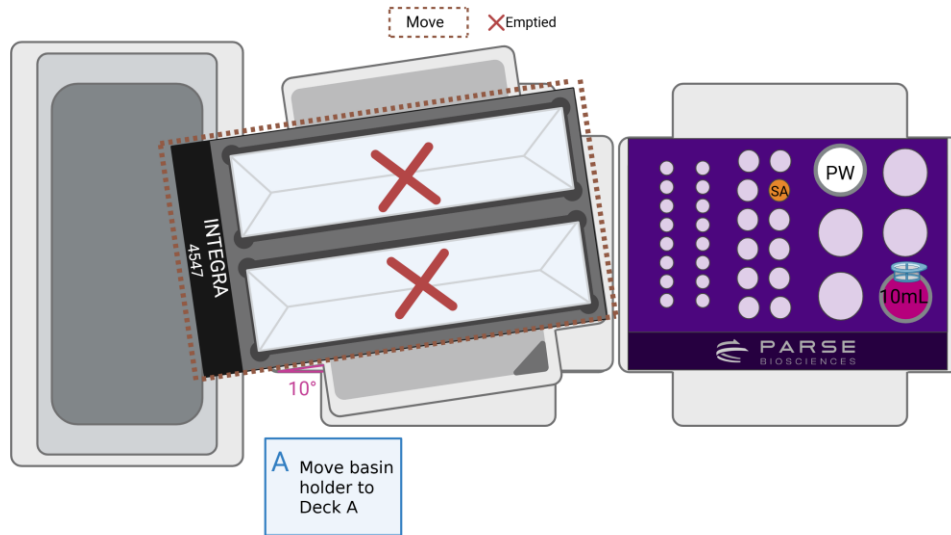

- a. Move the Dual Reservoir adapter back to Deck A. Ensure that the INTEGRA logo is facing the front.

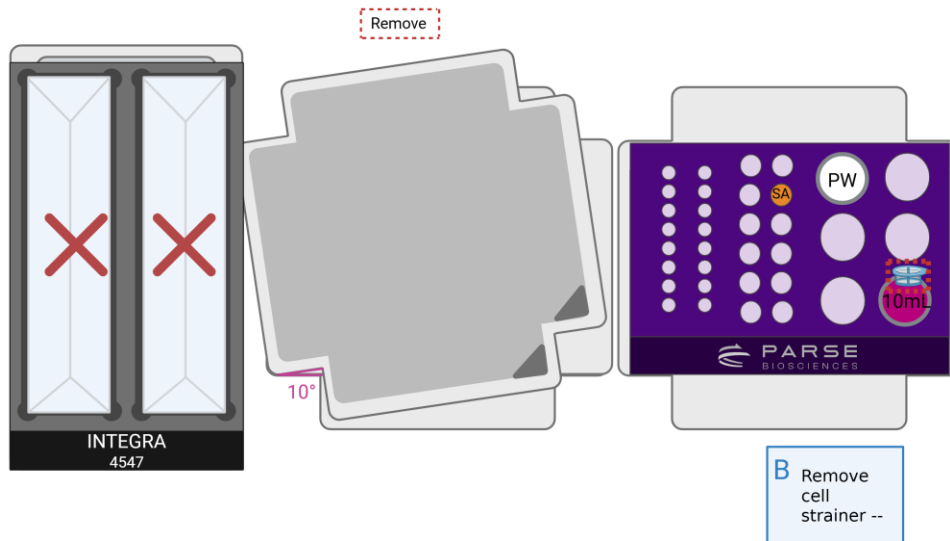

- b. Remove the used cell strainer from the 10 mL transport tube on Deck C, position 6.



Note: There may be bubbles left on the strainer. This will not affect the results.

9. Press “Run” to continue the program. Follow the program prompts for manual intervention:

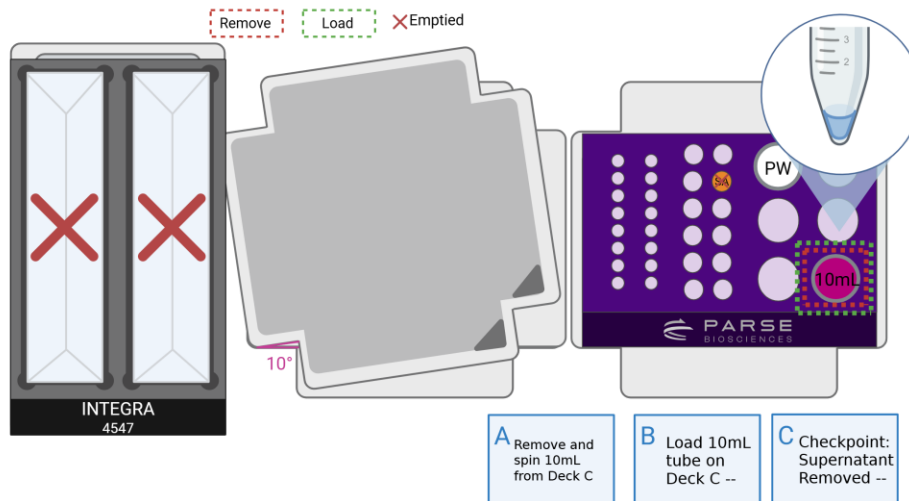

- Cap and invert once the 10 mL transport tube containing the pooled cells/nuclei. Centrifuge the sample in a swinging bucket centrifuge cooled to 4°C for **10 minutes** at 200-500 x g.
- Once centrifugation is complete, remove the cap from the 10 mL transport tube and place it back in its original position within the Parse Metal Cold Block on Deck C.
- After removing the supernatant, inspect the 10 ml tube and visually confirm that the supernatant has been removed, leaving only a small volume at the bottom. A pellet may not be visible. Avoid disturbing the pellet—do not insert the pipette tip into the pellet area to measure the supernatant.



CRITICAL! Return the 10 mL transport tube to the Parse Metal Cold Block immediately after centrifugation. Handle the tube with care to avoid jostling or disturbing the pellet. If the pellet becomes resuspended prior to supernatant removal, it may lead to loss of cells/nuclei.

10. Press “Run” to continue the program. Follow the program prompts for manual intervention:

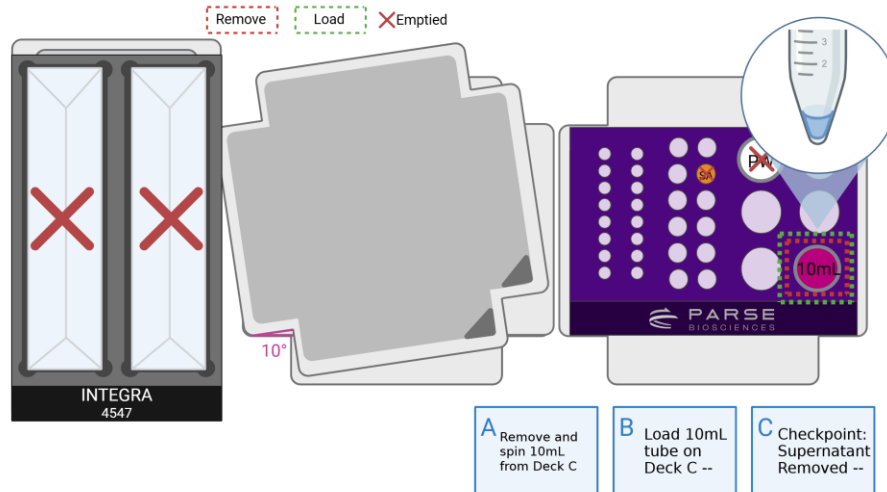

- Cap and invert once the 10 mL transport tube containing the pooled cells/nuclei. Centrifuge the sample in a swinging bucket centrifuge cooled to 4°C for **10 minutes** at 200-500 x g.
- Once centrifugation is complete, remove the cap from the 10 mL transport tube and place it back in its original position within the Parse Metal Cold Block located on Deck C, position 6.
- After removing the supernatant, inspect the 10 ml tube and visually confirm that the supernatant has been removed, leaving only a small volume at the bottom. A pellet may not be visible. Avoid disturbing the pellet—do not insert the pipette tip into the pellet area to measure the supernatant.



CRITICAL! Immediately return the 10 mL transport tube to the Parse Metal Cold Block after centrifugation. Handle the tube with care to avoid jostling or disturbing the pellet. If the pellet becomes resuspended prior to supernatant removal, it may lead to loss of cells/nuclei.

11. At the conclusion of the run:

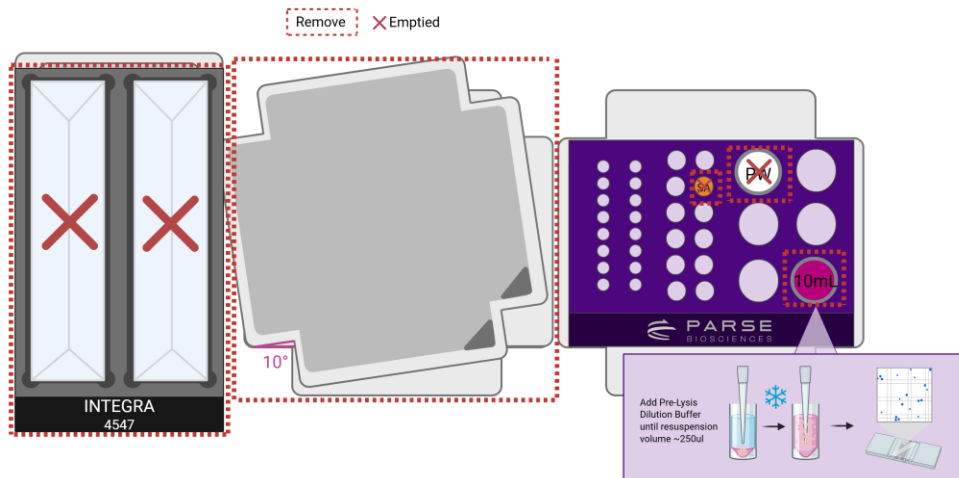

- a. Store the 10 mL transport tube on Deck C on ice. If the remaining volume in the 10 mL transport tube is less than 100 μL , add ● Pre-Lysis Dilution Buffer for a final total volume of 250 μL . Minimizing time on ice, mix and count the number of cells/nuclei in the sample from the 10 mL transport tube on Deck C with a hemocytometer or alternative counting device. Record the cell/nuclei count.



Note: Only count intact cells/nuclei. Including damaged or broken cells/nuclei can compromise data quality and will be excluded during downstream analysis.

- b. Discard the used 1.5 mL and 5 mL reagent tubes on Deck C.
- c. Keep the Parse Metal Cold Block on Deck C. It will be used in the next step.
- d. Remove all labware on Deck A. Discard the used reservoir liners and their contents.
- e. Remove all labware on Deck B.

1.8. Lysis and Sublibrary Generation

The program requires a dilution of the sample to 2500 cells/nuclei per μL with a volume of 420 μL . The program will create sixteen lysates with 62,500 cells/nuclei each. It then mixes the Lysis Master Mix and aliquots the master mix into the generated lysates.

To generate and lyse sublibraries:

1. Gather the following components and reagents:

ITEM	SOURCE	QTY	HANDLING AND STORAGE
D-ONE Pipetting Module 1-Ch, 5-1250 μL	INTEGRA Component	1	
Tip Deck for D-ONE Pipetting Module	INTEGRA Component	1	
Parse Metal Cold Block	Parse	1	Keep on ice when not in use.
8-count PCR strip tube	Consumables	2	
1.5 mL tube	Consumables	2	
125 μL Tip Rack	INTEGRA	1	
1250 μL Tip Rack	INTEGRA	1	
● Lysis Buffer	4°C Reagents	1	Place in a 37°C water bath until use.
● Lysis Enzyme	-20°C Reagents	1	Place directly on ice. Briefly centrifuge before use.

2. Dilute the cells to a concentration of 2,500 cells/nuclei per μL for a total volume of at least **420 μL** using the ● Pre-Lysis Dilution Buffer in a 1.5 mL transport tube. Store this dilution on ice until ready to use.

Note: If you do not have at least 1,000,000 cells/nuclei, dilute the remaining cells to 420 μL and record the amount of cells per sublibrary.



Note: The robot uses 25 μL of this sample dilution to generate the lysates. If lysates of another size is required, dilute the sample suspension to a different concentration. (Example: A sample suspension with the concentration of 300 cells per μL will create lysates with 7,500 cells/nuclei.)

Note: Automated dispensing of 1,000,000 cells/nuclei across 16 sublibraries requires a minimum input of 1,050,000 cells/nuclei. If fewer than 1,050,000 cells/nuclei are

available, the dispensing can be performed manually to ensure maximum utilization of all available cells/nuclei.

3. The deck layout should correspond to the configuration below.

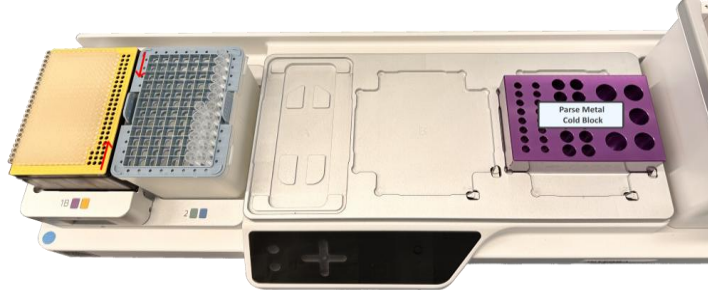

4. Load the following reagents to their respective positions on the Parse Metal Cold Block on Deck C.
 - a. Column 1 left: Two 8-count PCR strip tubes.
 - b. Column 2:
 - i. Pos 1: diluted sample in a 1.5 mL tube.
 - ii. Pos 6: a clean 1.5 mL tube.
 - iii. Pos 11: ● Lysis Buffer.
 - iv. Pos 12: ● Lysis Enzyme.

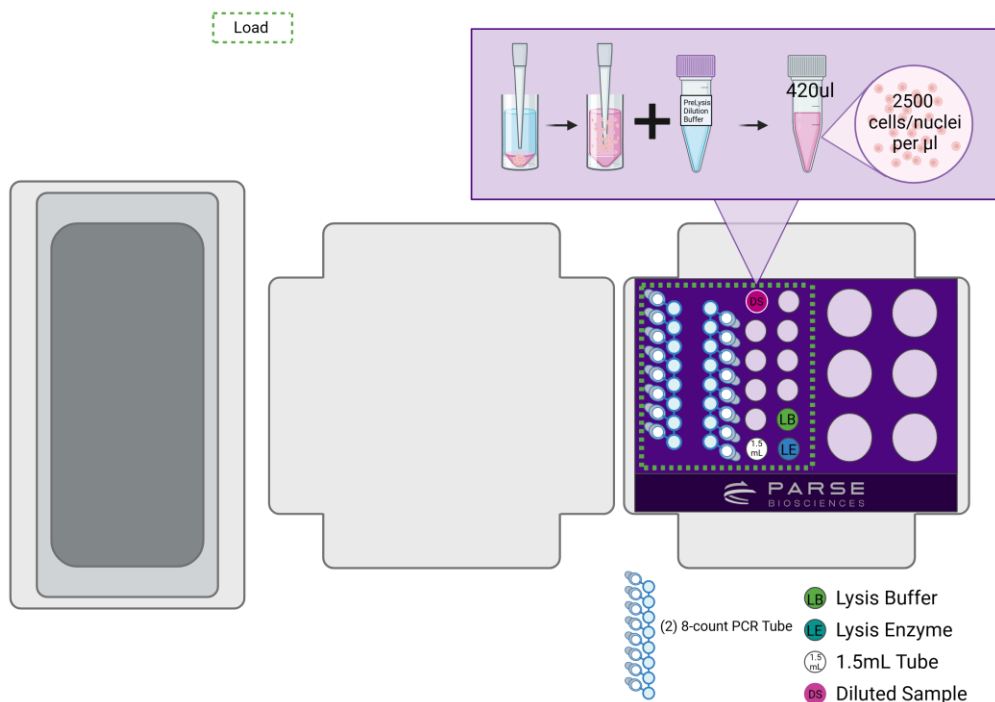

5. Remove the reagent caps, ensure that all strip tubes are open, select and run the program **MG S1 St8 V3_5** following the diagram below.

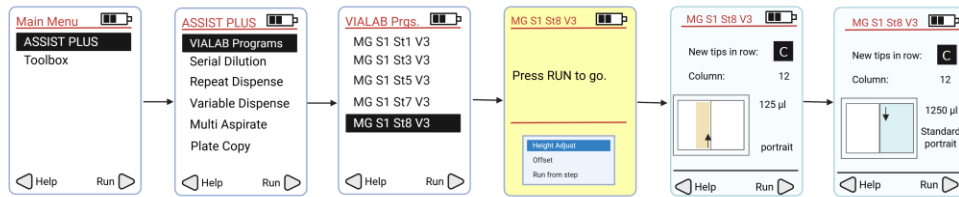

6. At the conclusion of the run:
 - a. Remove the PCR strip tubes from Deck C. Securely cap and vortex the 0.2 mL tube(s) for **10 seconds**. Briefly centrifuge. Place the tube(s) into a thermocycler and run the following program.

CELL/NUCLEI LYSIS		
Run Time	Lid Temperature	Sample Volume
15 min	80°C	55 µL
Step	Time	Temperature
1	15 min	65°C
2	Hold	4°C

- b. Freeze the lysate(s) at -80°C or proceed to Section 2 while the program is still running.



Safe stopping point: Sublibrary lysates can be stored at -80°C for up to 6 months.

Section 2: cDNA Capture and Amplification

2.1. Reagents Plating

SPRI beads, Streptavidin Beads, and Binding Buffer are dispensed into 8-count PCR strip tubes. The Bead Wash, Wash 1, Wash 2, and Wash 3 Buffers are dispensed into the INTEGRA 8 Row Reservoir on Deck A. Capture enhancer is then added to the lysates created in Section 1.

1. Fill an ice bucket.
2. Gather the following items and handle as indicated below.

ITEM	SOURCE	QTY	HANDLING AND STORAGE
D-ONE Pipetting Module 1-Ch, 5-1250 µL	INTEGRA Component	1	
Tip Deck for D-ONE Pipetting Module	INTEGRA Component	1	
24 mm Labware Pedestal	INTEGRA Component	1	
Parse Metal Cold Block	Parse	1	Keep on ice when not in use.
HEATMAG with 96 Well Adapter	INTEGRA Component	1	
8 Row Reservoir	INTEGRA	1	Individually wrapped consumable
300 mL Reservoir Base	INTEGRA	1	
8-count PCR strip tubes	Consumables	3	
125 µL Tip Rack	INTEGRA	1	
1250 µL Tip Rack	INTEGRA	1	
● Streptavidin Beads	4°C Reagents	1	Keep at room temperature.
● Binding Buffer	-20°C Reagents	1	Thaw at room temperature then store on ice. Mix by inverting 3x.
● Capture Enhancer	-20°C Reagents	1	Place directly on ice. Briefly centrifuge before use.

ITEM	SOURCE	QTY	HANDLING AND STORAGE
○ Bead Wash Buffer	-20°C Reagents	1	Thaw at room temperature then store on ice. Mix by inverting 3x.
○ Wash Buffer 1	-20°C Reagents	1	
○ Wash Buffer 2	-20°C Reagents	1	
○ Wash Buffer 3	-20°C Reagents	1	
SPRI Beads	Consumables and Reagents		Equilibrate at room temperature before use.

- Place the 24 mm Labware Pedestal on Deck A.
- Place the Parse Metal Cold Block on Deck B.
- Place the HEATMAG with 96 Well PCR Adapter (INTEGRA logo oriented to the front) on Deck C. Ensure HEATMAG power is on for the entire duration of Section 2.



- Attach D-ONE Pipetting Module 1-Ch, 5-1250 μL and the corresponding tip rack.
- On the 24 mm Pedestal, place a clean INTEGRA 8 Row Reservoir with the 300 mL Reservoir Base.
- Vortex, and dispense **1,420 μL** SPRI beads into a 2 mL tube.
- Vortex ● Streptavidin Beads.



Note: Ensure that the ● Streptavidin Beads and SPRI Beads are thoroughly mixed before placing them on the deck. Beads can settle if the program isn't started immediately after loading all reagents.

10. Briefly centrifuge and load the following reagents and consumables to their respective positions on the Decks A, B and C:

- a. Deck A: clean 8 Row Reservoir.
- b. Deck B, column 1, left: a clean 8-count PCR strip tube.
- c. Deck B, column 2:
 - i. Pos 5: Fully resuspended SPRI beads
 - ii. Pos 6: ● Binding Buffer.
 - iii. Pos 11: ● Capture Enhancer.
 - iv. Pos 12: Fully resuspended ● Streptavidin Beads.
- d. Deck B, column 3:
 - i. Pos 1: ○ Bead Wash Buffer.
 - ii. Pos 2: ○ Wash Buffer 1.
 - iii. Pos 3: ○ Wash Buffer 2.
- e. Deck C: Two clean 8-count PCR strip tubes with the caps facing to the left in columns 5 and 7 on the HEATMAG.

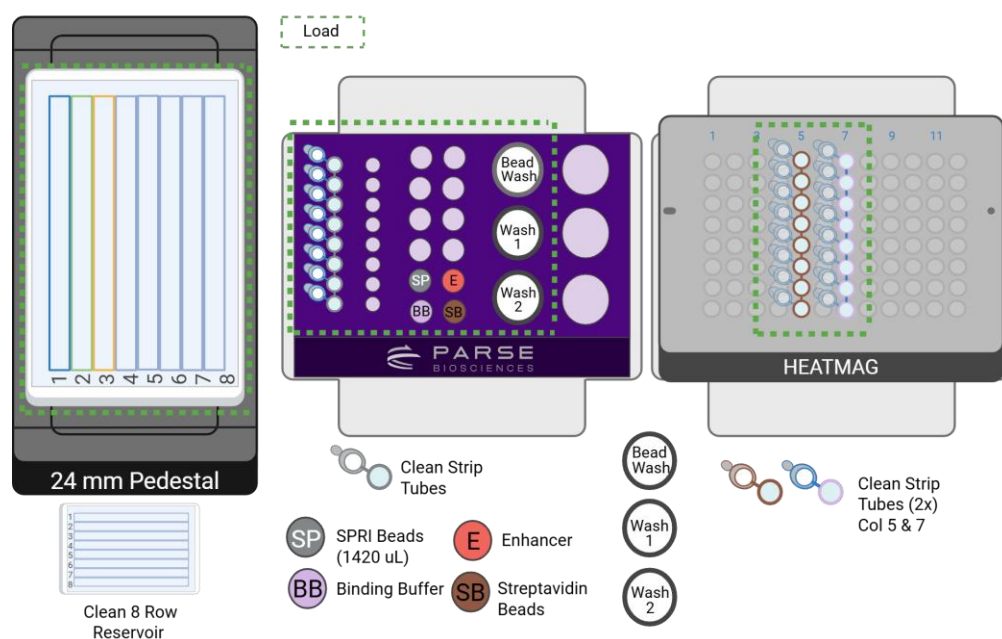

11. Remove the reagent caps and ensure that all strip tubes are open.

12. On the D-ONE Pipette select and run the program **MG S2 St1 V3_5** following the diagram below.

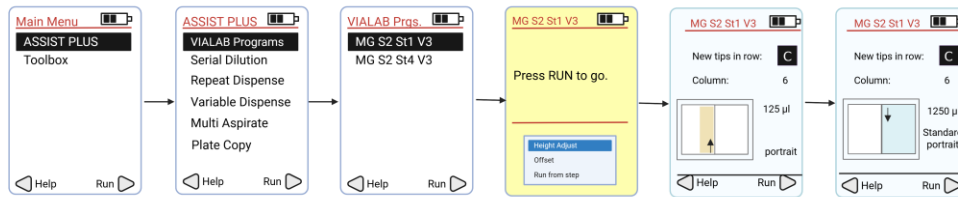

13. If continuing directly from Section 1, store lysates on ice until prompted.

14. If lysates are previously frozen, when prompted, incubate the lysates in a thermocycler at 37°C for **5 minutes** to thaw them. Press "Run" on the pipette to continue the program while the lysates are thawing.



Note: The program will remind you to thaw the lysate. Press "Run" to continue the program if continuing directly from Section 1.

Note: When thawing the lysate, ensure there is no precipitate before proceeding. Otherwise, an additional 5 minutes at 37°C should be sufficient.

15. When the lysates finish thawing, briefly centrifuge and store at room temperature.

16. Press "Run" to continue the program. Follow the program prompts for manual intervention:

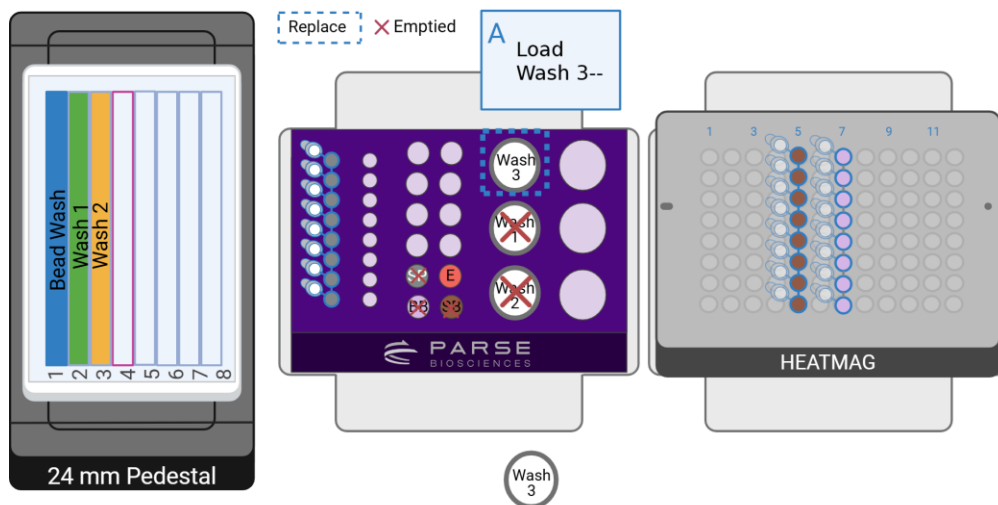

- a. Replace the ○ Bead Wash Buffer with ○ Wash Buffer 3 on Deck B, column 3, position 1.

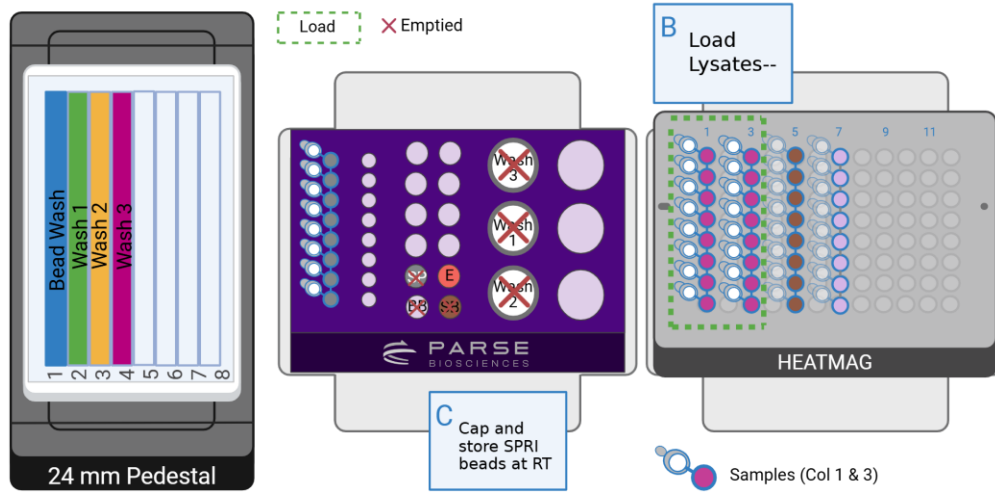

- b. Load the thawed lysates in columns 1 and 3 of the HEATMAG with 96 Well PCR Adapter. Press "Run" to continue.



Note: Ensure the 8-count PCR strip tube caps are facing the same direction. Push the PCR strip tube caps wide open to avoid interference with the pipette's tips.

- c. When prompted, cap and store the PCR strip tubes on column 1 left position of the Parse Metal Cold Block on Deck B at room temperature until after cDNA cleanup. Label these tubes as SPRI beads.

18. At the conclusion of the run:

- a. Verify that Streptavidin Bead volumes in column 5 of Deck C are even.
- b. Verify that the Binding Buffer volumes in column 7 of Deck C are even.
- c. Verify that all wash buffers have been transferred to the 8 Row Reservoir.



Note: Refer to Appendix B for specific volumes.

- d. Remove and discard empty tubes on Deck B. Place the SPRI bead tubes aside for later use.
- e. Proceed immediately to Section 2.2.

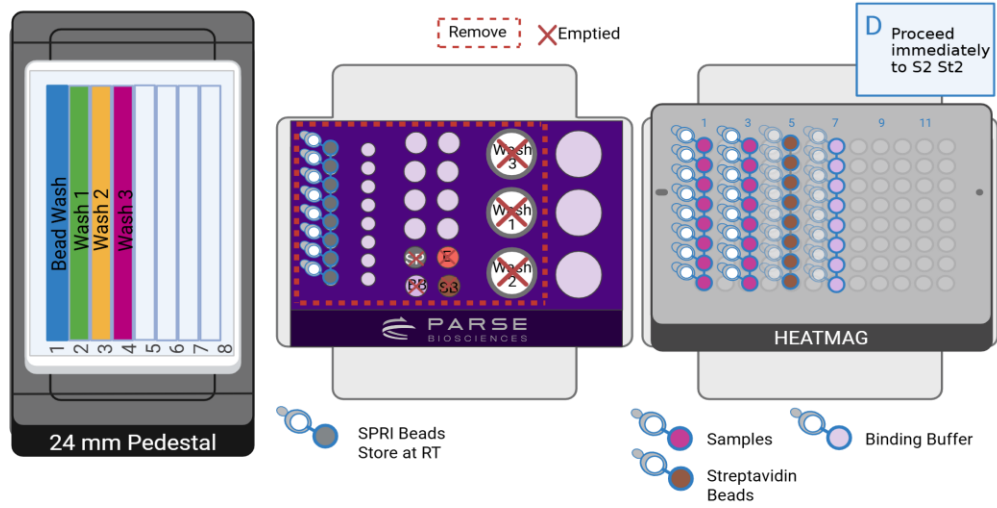

2.2. cDNA Capture

Streptavidin Beads are washed, then cDNA is captured with streptavidin-coated magnetic beads. The program controls the temperature and strength of the HEATMAG with 96 Well Adapter on Deck C.

To capture the cDNA:

1. Gather the following items and set up the deck as shown.

ITEM	SOURCE	QTY	HANDLING AND STORAGE
VOYAGER Pipetting Module 8-Ch 5-125 μ L	INTEGRA Component	1	
Tip Deck for VOYAGER Pipetting Module	INTEGRA Component	1	
125 μ L Tip Rack	INTEGRA	1	

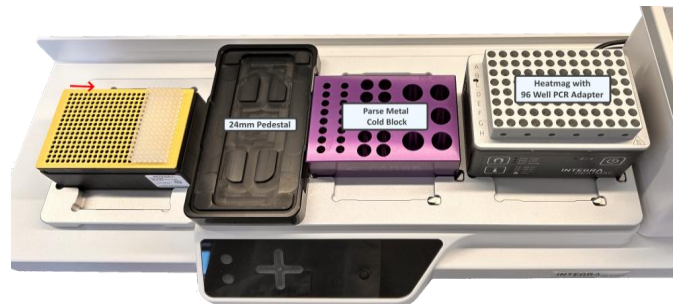

2. Load the following uncapped strip tubes (if removed from previous steps) to their respective positions on the HEATMAG with 96 Well PCR Adapter:
 - a. Samples on columns 1 and 3.
 - b. Streptavidin Beads on column 5.
 - c. Binding Buffer on column 7.

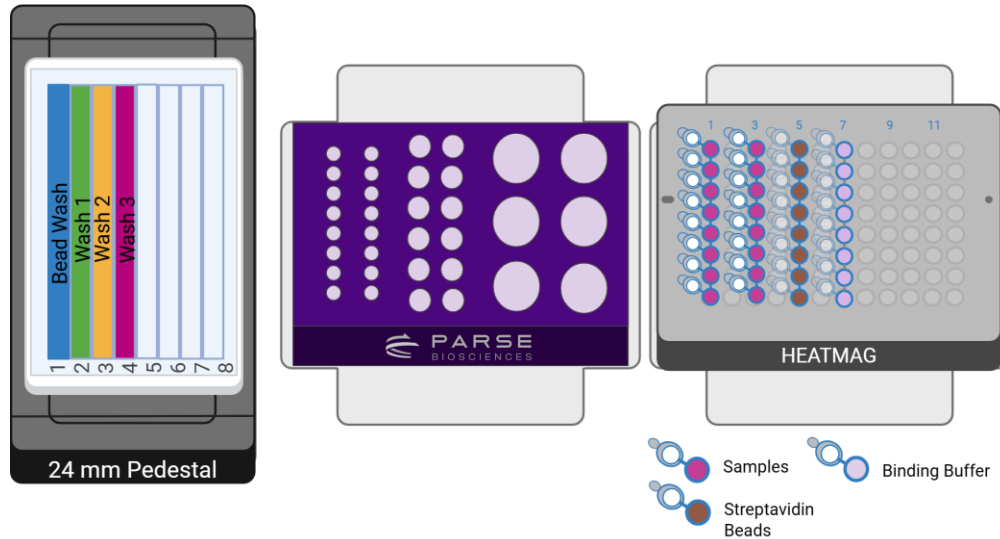

3. Change the pipette that is connected to the INTEGRA ASSIST PLUS:
 - b. Remove D-ONE Pipetting Module 1-Ch, 5-1250 μ L and corresponding Tip Deck. Ensure it is disconnected by pressing the back button until the main menu is displayed.
 - c. Replace it with VOYAGER 8-Ch 5-125 μ L Pipette and corresponding Tip Deck. Ensure the Tip Deck and Tip Box are securely positioned by pressing them down firmly until they click into place. Remove the tip box lid prior to starting the program.
4. Select and run the program **MG S2 St2 V3_5** following the diagram below.

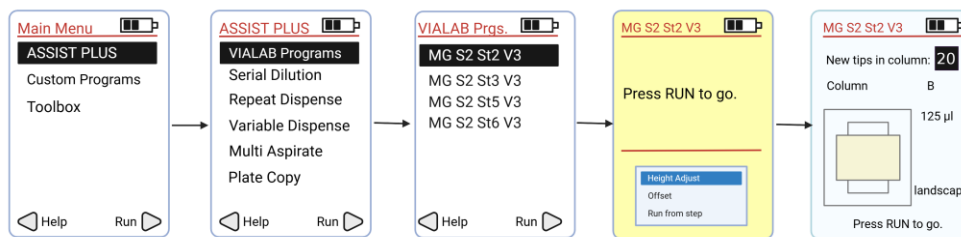

5. Press "Run" to continue the program. Follow the program prompts for manual intervention:
 - a. Cover the 8 Row Reservoir to avoid contamination.
 - b. Cap the sample strip tubes on Deck C columns 1 and 3.
 - c. Place the strip tubes into a 96 well PCR tube rack, press to secure, and ensure the caps are secured tightly.
 - d. Place the rack onto a vortex mixer with a plate adapter. Push to secure. Vortex on 100% power for **1 minute**.
 - e. Vortex on 20% power (~800-1000 RPM) for **30 minutes** at room temperature.



Note: To ensure the beads are being mixed sufficiently, check that the beads are in solution **10 minutes** into the incubation. If settled, increase the vortex mixing speed to keep the beads in solution.

- f. While the samples are vortexing, press "Run" to complete the program.
- g. Discard the used strip tubes in columns 5 and 7 on Deck C and proceed to Section 2.3.

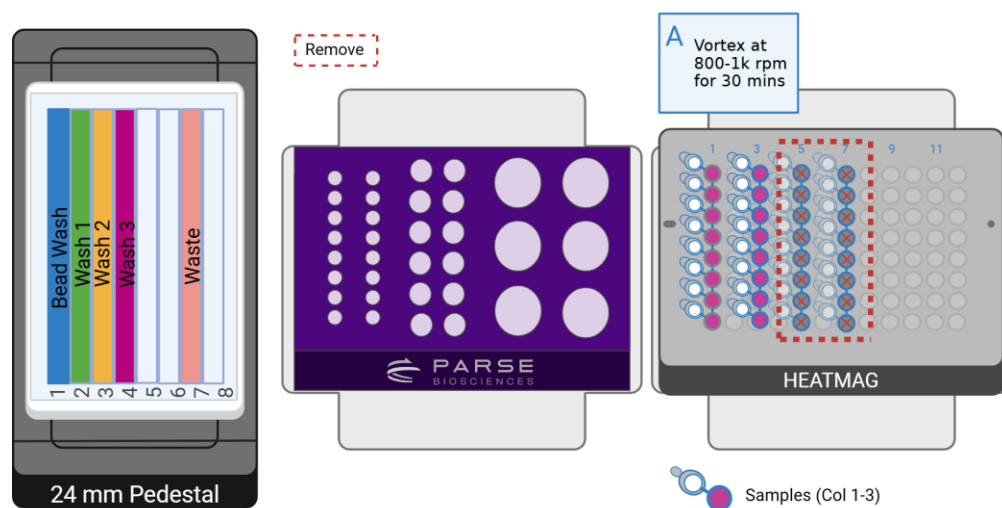

2.3. Streptavidin Beads Wash

Captured cDNA samples are washed to remove cellular debris.

1. Briefly centrifuge the captured cDNA sample tubes for **30 seconds** at 100 x g at 4°C.
2. Uncap and place the sample tubes back on the HEATMAG with 96 Well Adapter on Deck C, columns 1 and 3.



Note: Ensure the PCR strip tube caps are facing the same direction. Push the PCR strip tube caps wide open to avoid interference with the pipette's tips.

3. Uncover the 8 Row Reservoir. The deck layout should correspond to the configuration below.

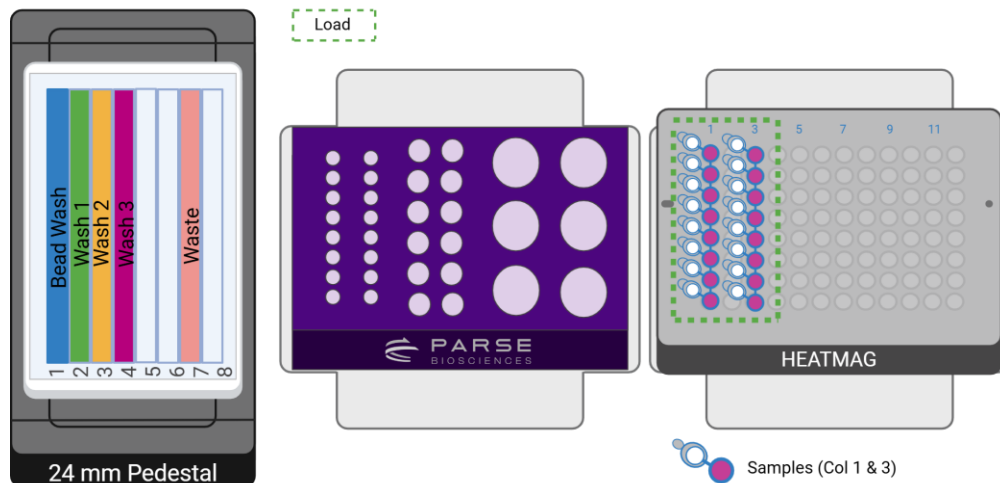

4. Select and run the program **MG S2 St3 V3_5** following the diagram below.

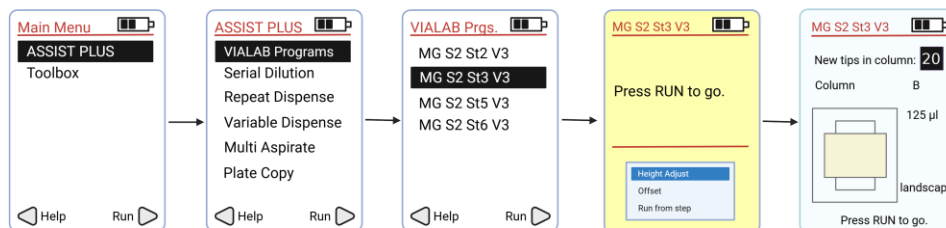

5. At the conclusion of the run, proceed immediately to section 2.4.

2.4. Master Mixes Preparation

The program prepares the Template Switch Master Mix and the cDNA Amplification Master Mix for the template switch and the cDNA amplification reactions.

To prepare reagents:

1. Gather the following items and handle as indicated below:

ITEM	SOURCE	QTY	HANDLING AND STORAGE
D-ONE Pipetting Module 1-Ch, 5-1250 μ L	INTEGRA Component	1	
Tip Deck for D-ONE Pipetting Module	INTEGRA Component	1	
Parse Metal Cold Block	Parse	1	
24 mm Labware Pedestal	INTEGRA Component	1	
HEATMAG with 96 Well Adapter	INTEGRA Component	1	
300 mL Reservoir Base	INTEGRA Component	1	
8-count PCR strip tubes	Consumables	2	
2 mL tubes	Consumables	2	
125 μ L Tip Rack	INTEGRA	1	
1250 μ L Tip Rack	INTEGRA	1	
● Template Switch Buffer	-20°C Reagents	1	Thaw at room temperature then place on ice. Mix by inverting 3x. Briefly centrifuge before use.
● Template Switch Primer	-20°C Reagents	1	
● Template Switch Enzyme	-20°C Reagents	1	Keep on ice. Briefly centrifuge before use.
● cDNA Amp Mix	-20°C Reagents	1	Thaw at room temperature then place on ice. Mix by inverting 3x. Briefly centrifuge before use.
● cDNA Amp Primers	-20°C Reagents	1	



Note: Ensure that there is no precipitate in the ● Template Switch Buffer before proceeding.

2. Set up the deck following the Deck Configuration below.



3. On Deck B, on the Parse Metal Cold Block, place the following consumables and reagents using the deck configuration below:

- a. Column 1 left and right: two clean 8-count PCR strip tubes.
- b. Column 2:
 - i. Pos 1: ● Template Switch Buffer.
 - ii. Pos 2: ● Template Switch Enzyme.
 - iii. Pos 3: ● Template Switch Primer.
 - iv. Pos 4: a clean 2 mL tube.
 - v. Pos 7: ● cDNA Amp Mix.
 - vi. Pos 8: ● cDNA Amp Primers.
 - vii. Pos 9: a clean 2 mL tube.

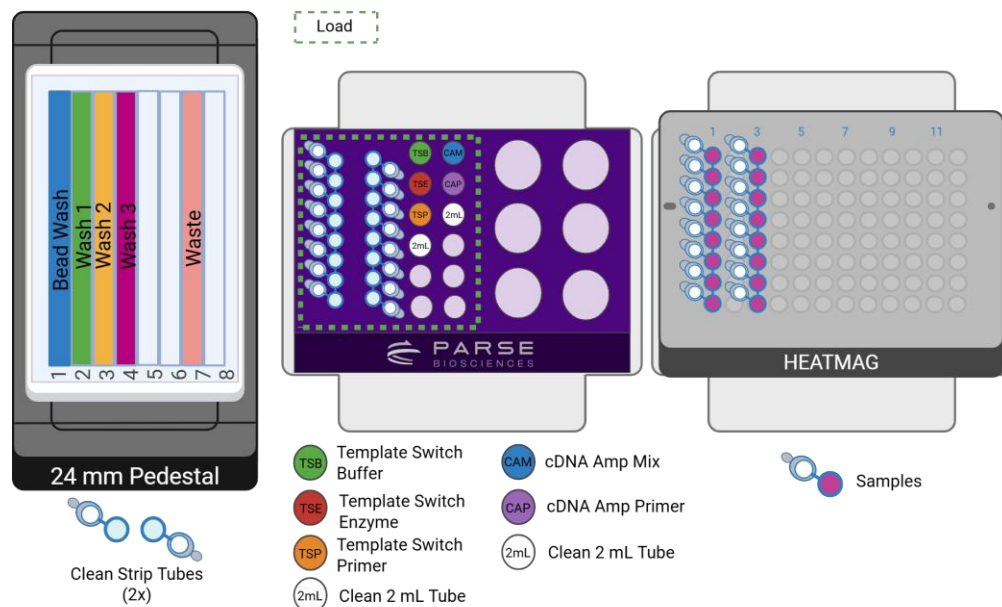

4. Change the pipette that is connected to the INTEGRA ASSIST PLUS:
 - a. Remove the VOYAGER 8-Ch 5-125 μ L Pipette and corresponding Tip Deck. Ensure it is disconnected by pressing the back button until the main menu is displayed.
 - b. Replace it with D-ONE Pipetting Module 1-Ch, 5-1250 μ L and corresponding Tip Deck. Ensure the tip deck and tip boxes are securely positioned by pressing them down firmly until they click into place. Remove the tip box lids prior to starting the program.
5. Remove the reagent caps, select and run the program **MG S2 St4 V3_5** following the diagram below.

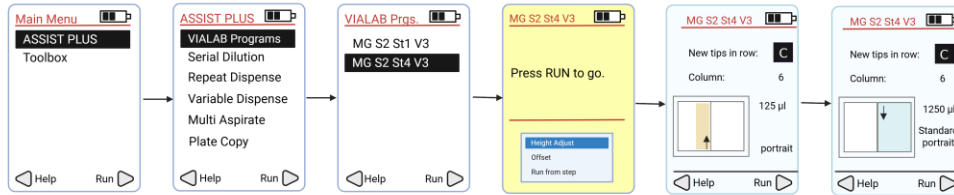

6. Press "Run" to continue the program. Follow the program prompts for manual intervention:
 - a. Cap, label, and store the cDNA Amplification Master Mix dispensed in the right PCR strip tube on Deck B, column 1, right side on ice. Verify the volume is even. Press "Run" to continue.

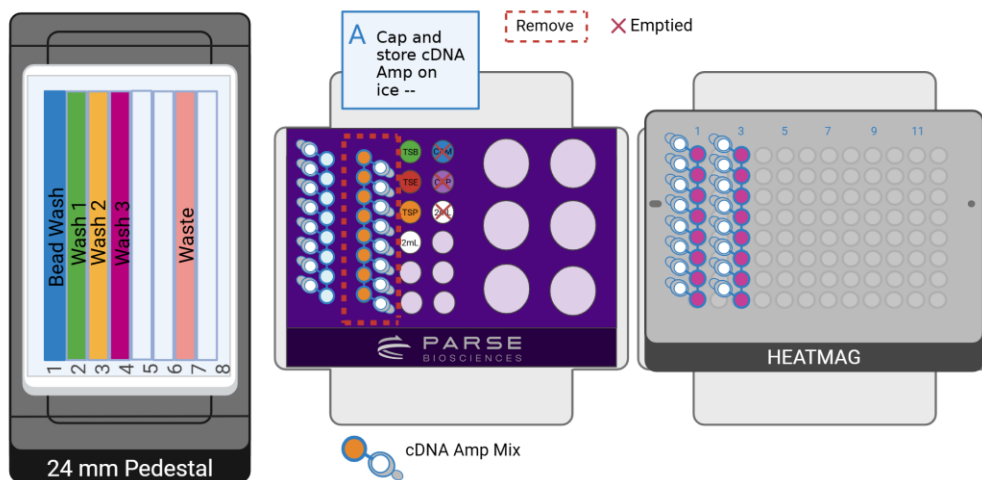

7. At the conclusion of the run:
 - a. Verify that the volume of the Template Switch Master Mix in the left PCR strip tube on Deck B, column 1 left is even (~210 μ L). Keep it on this position as it will be used in the next step.

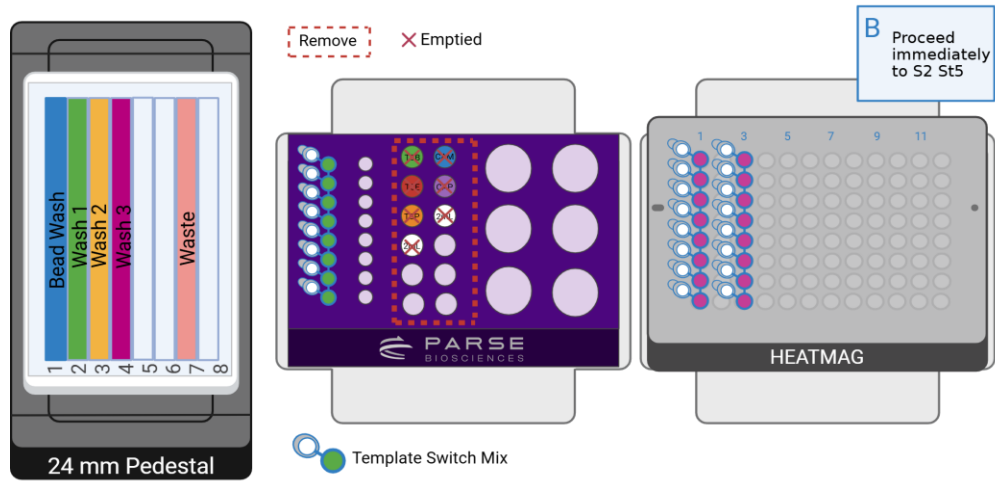

- b. Remove and discard used 1.5 mL and 2 mL reagent tubes on Deck B, column 2.

2.5. Template Switch and cDNA Amplification

The Template Switch Master Mix is added to the captured cDNA and incubated for 30 minutes. The template switch reaction adds a 5' adapter to the cDNA.

To perform template switch:

1. Gather the following items and set up the deck indicated:

ITEM	SOURCE	QTY	HANDLING AND STORAGE
VOYAGER 8-Ch 5-125 μ L	INTEGRA Component	1	
Tip Deck for VOYAGER Pipetting Module	INTEGRA Component	1	
Parse Metal Cold Block	Parse	1	
24 mm Labware Pedestal	INTEGRA Component	1	
HEATMAG with 96 Well Adapter	INTEGRA Component	1	
300 mL Reservoir Base	INTEGRA Component	1	
125 μ L Tip Rack	INTEGRA	1	

2. Ensure the following are loaded following the deck configuration below:
 - a. Deck B, column 1, left: 8-count PCR strip tube with Template Switch Master Mix.
 - b. Deck C, columns 1 and 3: Samples on the HEATMAG with 96 Well PCR Adapter.



Note: Ensure the PCR strip tube caps are facing the same direction. Push the PCR strip tube caps wide open to avoid interference with the pipette's tips.

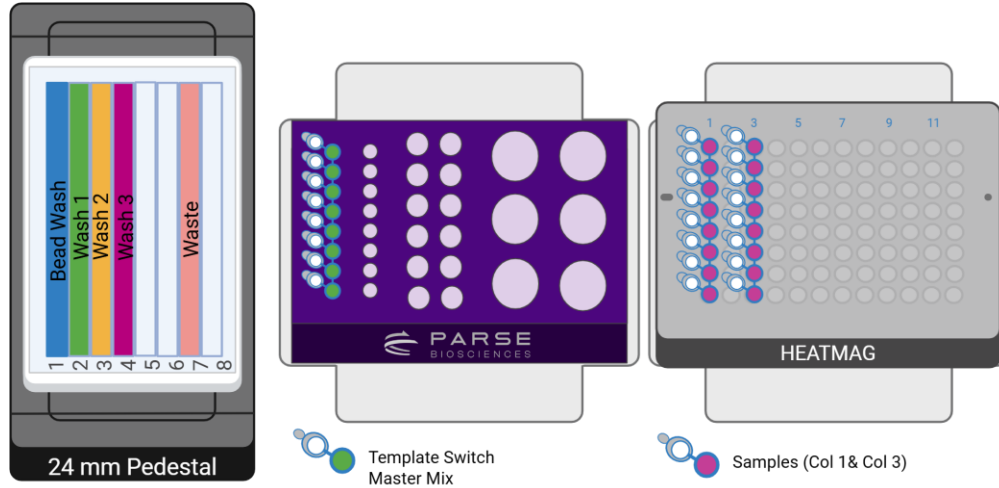

3. Change the pipette that is connected to the INTEGRA ASSIST PLUS:
 - a. Remove D-ONE Pipetting Module 1-Ch, 5-1250 μ L and corresponding Tip Deck. Ensure it is disconnected by pressing the back button until the main menu is displayed.
 - b. Replace it with VOYAGER 8-Ch 5-125 μ L Pipette and corresponding Tip Deck. Ensure the Tip Deck and Tip Box are securely positioned by pressing them down firmly until they click into place. Remove the tip box lid prior to starting the program.
4. On the VOYAGER Pipette select and run the program **MG S2 St5 V3_5** following the diagram below.

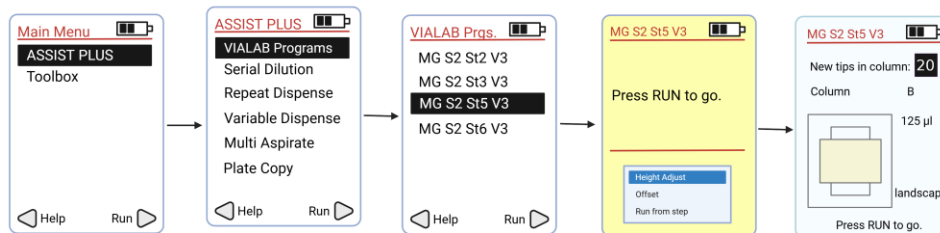

- Press "Run" to continue the program. Follow the program prompts for manual intervention:

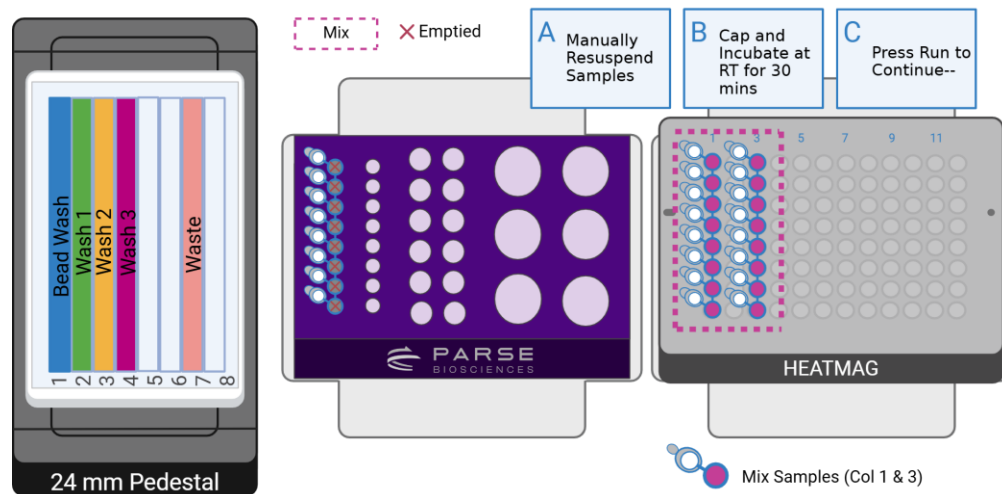

- Remove the samples from the deck and manually mix to fully resuspend the streptavidin pellet in the Template Switch Master Mix. Avoid introducing bubbles.



Note: The Template Switch Master Mix is viscous, which can make resuspending the beads challenging. Do not directly touch the bead pellet with the pipette tip, as the beads may stick to it.

- Cap the sample strip tubes on Deck C column 1. Incubate the cDNA samples on Deck C, columns 1 and 3 at room temperature for **30 minutes**. Add a PCR plate seal to the reagent reservoir on Deck A during the 30 minute incubation.
- After the 30 minute incubation, uncap the sample strip tube caps. Press "Run" to continue the program.



Note: Ensure the PCR strip tube caps are facing the same direction. Push the PCR strip tube caps wide open to avoid interference with the pipette's tips.

6. When prompted, remove the samples from the Deck C, columns 1 and 3 and place them into a thermocycler. Run the following program.

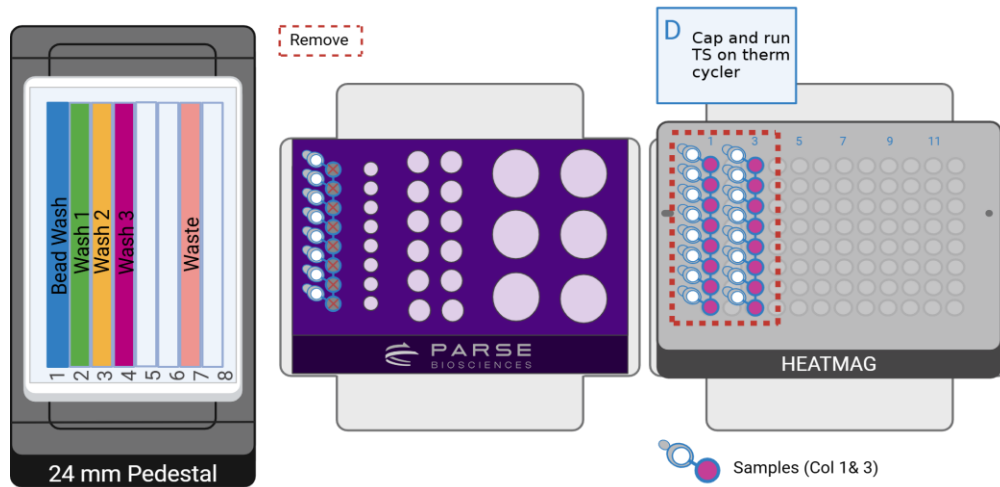

TEMPLATE SWITCH		
Run Time	Lid Temperature	Sample Volume
60 min	70°C	100 µL
Step	Time	Temperature
1	60 min	42°C
2	Hold	4°C

7. Press "Run" to continue the program. Follow the program prompts for manual intervention:

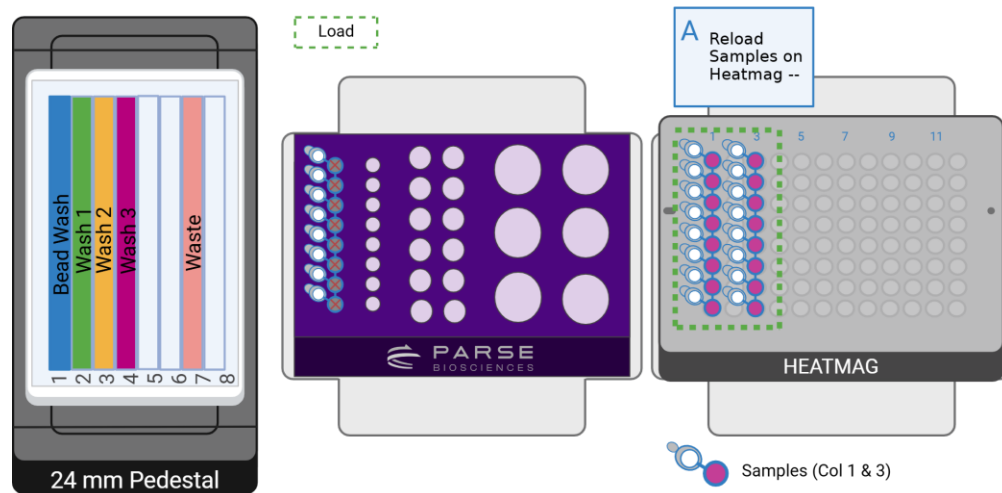

- a. When the Template Switch thermocycling program has completed, remove the cover from the 8 Row reservoir on Deck A and reload the samples on the HEATMAG on Deck C columns 1 and 3.



Note: Ensure the PCR strip tube caps are facing the same direction to the left. Push the PCR strip tube caps wide open to avoid interference with the pipette's tips.

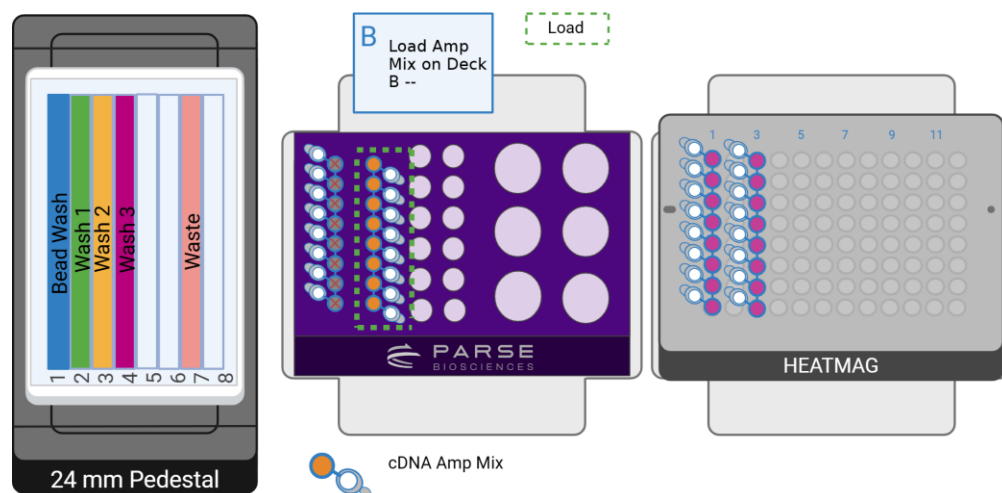

- b. Place the cDNA Amplification Master Mix from section 2.4.6 back into Deck B, column 1, right. Press "Run" to continue the program.

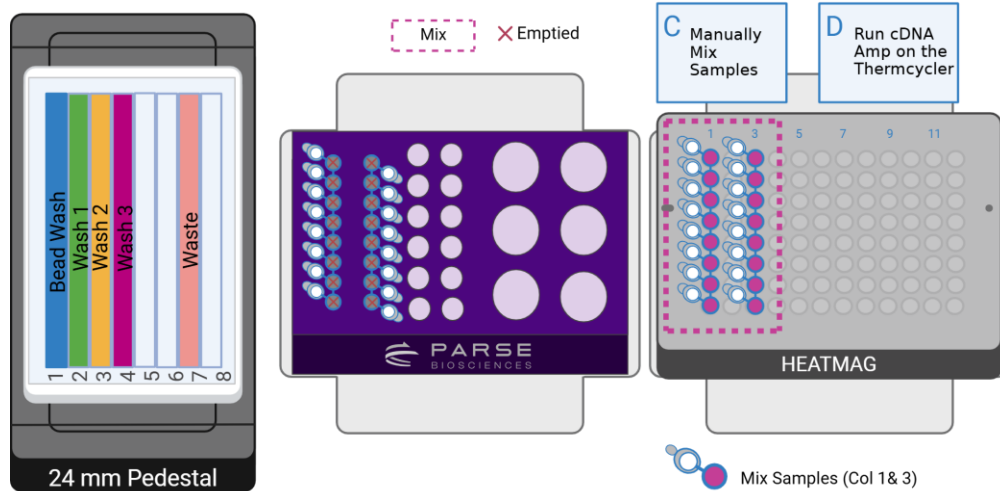

- c. Remove the samples from the deck and manually mix to fully resuspend the streptavidin pellet in the cDNA Amp Mix. Avoid introducing bubbles.
 - d. Use the guidelines below to amplify the cDNA samples.
8. Determine the number of PCR cycles required for cDNA amplification based on the table below. Although these recommendations are appropriate for many cell types, the number of cycles may need to be optimized for each sample type.

NUMBER OF PCR CYCLES			
Cells/nuclei in the Sublibrary	High RNA content such as cell lines	Low RNA content such as PBMCs	Nuclei
200-1,000	11	13	12
1,000-2,000	9	11	10
2,000-6,000	7	9	8
6,000-12,500	6	8	7
12,500-25,000	4	6	5
25,000-62,000	3	5	4

9. When prompted, place the sample strip tube into thermocycler and run the following program.

cDNA AMPLIFICATION			
Run Time	Lid Temperature	Sample Volume	
50-70 min	105°C	100 µL	
Step	Time	Temperature	Cycles
1	3 min	95°C	1
2	20 sec	98°C	5
3*	45 sec	65°C*	
4	3 min	72°C	
5	20 sec	98°C	Variable, see above
6*	20 sec	67°C*	
7	3 min	72°C	
8	5 min	72°C	1
9	Hold	4°C	1



CRITICAL! If processing sublibraries with different numbers of cells/nuclei, they should be amplified in separate thermocyclers according to the recommendations above.



Note: Annealing steps 3* and 6* have different time and temperature settings. Ensure these are correct before starting the program.

10. While the thermocycler program is running:

- a. Remove and discard used strip tubes on Deck B.
- b. We recommend covering the 8 Row Reservoir with a PCR plate seal during this time to reduce contamination.

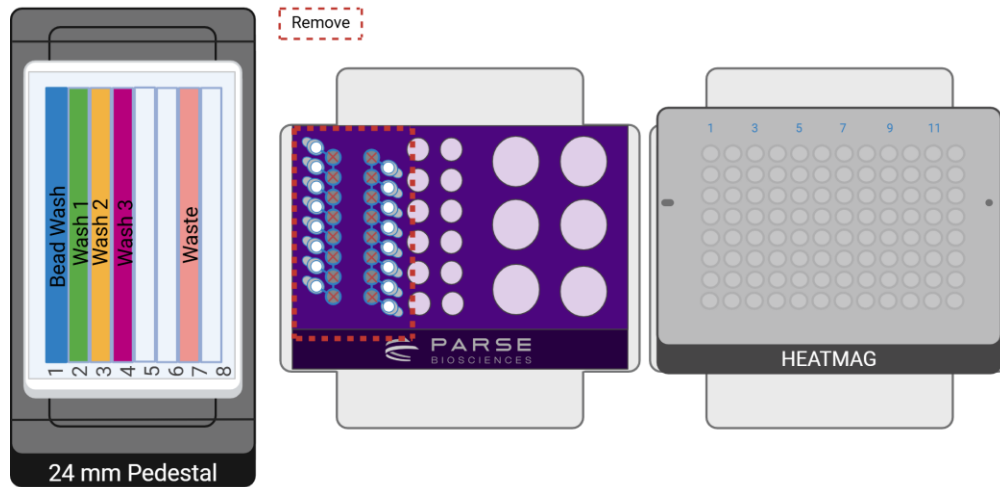

Safe stopping point: Amplified cDNA can be stored at 4°C for up to 18 hours.

2.6. Post-Amplification Purification

Amplified cDNA is purified with a 0.8x SPRI bead cleanup.

To purify the cDNA:

1. Gather the following items and set up the deck as indicated:

ITEM	SOURCE	QTY	HANDLING AND STORAGE
VOYAGER 8-Ch 5-125 μ L	INTEGRA Component	1	
Tip Deck for VOYAGER Pipetting Module	INTEGRA Component	1	
Parse Metal Cold Block	Parse	1	
24 mm Labware Pedestal	INTEGRA Component	1	
HEATMAG with 96 Well Adapter	INTEGRA Component	1	
300 mL Reservoir Base	INTEGRA Component	1	
125 μ L Tip Rack	INTEGRA	1	
8-count PCR strip tubes	Consumables	4	
Ethanol	Consumables and Reagents		
Nuclease free water	Consumables and Reagents		
SPRI Beads	Consumables and Reagents		

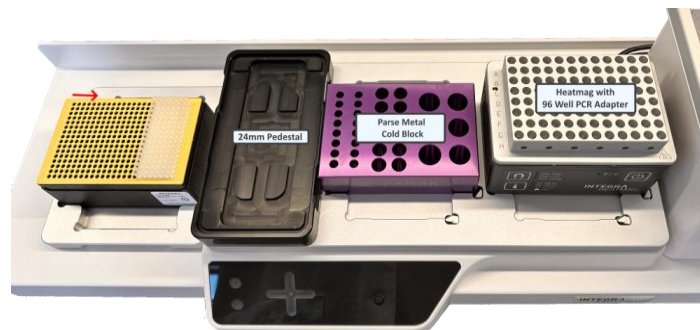

2. Prepare at least **8 mL** 85% ethanol with nuclease-free water.

3. With a P1000 pipette set at 1,000 μ L, add:
 - a. **8 mL** 85% Ethanol in lane **5** of the 8 Row Reservoir on Deck A.
 - b. **3.5 mL** nuclease free water in lane **6** of the 8 Row Reservoir on Deck A.
4. Place the dispensed SPRI beads in strip tubes from Section 2.1.17c on Deck B, column 1 (left) on the Parse Metal Cold Block. If the beads have settled, they should be manually resuspended prior to loading them on the Parse Metal Cold Block.



Note: Ensure the SPRI beads have been equilibrated to room temperature for at least 30 minutes.

5. Once the cDNA Amplification thermocycler program is complete, place the sample strip tubes in columns 1 and 3 on the HEATMAG with 96 Well Adapter on Deck C.



Note: Ensure the PCR strip tube caps are facing the same direction. Push the caps wide open to avoid interference with the pipette's tips.

6. Place 4 new 8-count PCR strip tubes in columns 5, 7, 9, and 11 on Deck C. The deck layout should correspond to the Deck Configuration below.

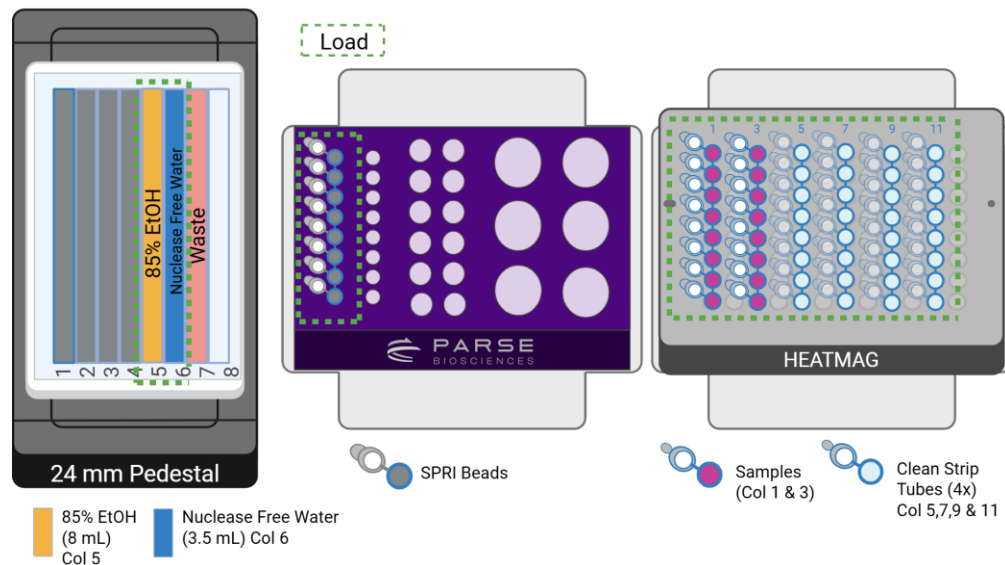

7. Select and run program **MG S2 St6 V3_5** following the diagram below.

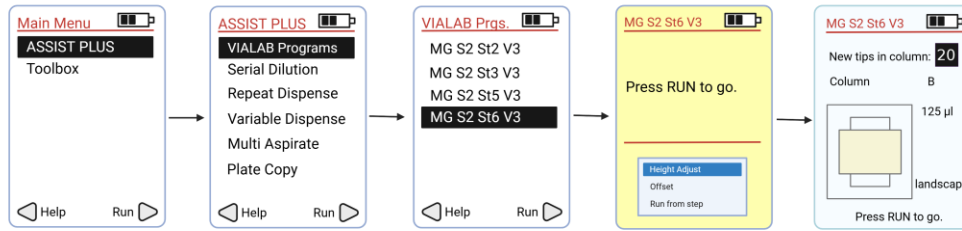

8. Press "Run" to continue the program. Follow the program prompts for manual intervention:

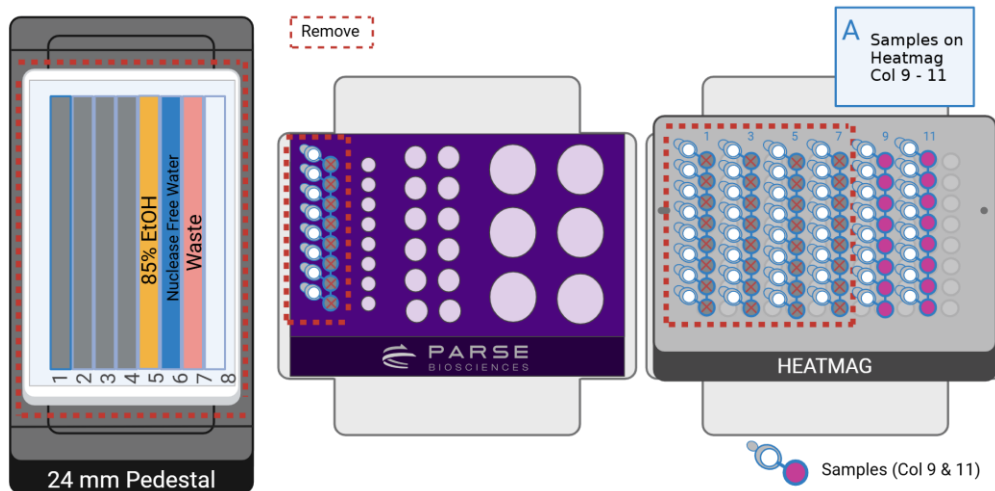

a. Final cDNA libraries are on the HEATMAG with 96 Well Adapter in columns 9 and 11. Remove and discard the empty strip tubes and the 8 row reservoir.

STOP Safe stopping point: Purified cDNA can be stored at 4°C for up to 48 hours or at -20°C for up to 3 months. Otherwise, proceed to Section 2.7 to quantify the cDNA before proceeding to section 3.

CRITICAL! In section 3, you will need two Thermochromic PCR Cold Blocks with Thermochromic PCR Cold Block Risers. One block should remain cold throughout the process, while the other should be at room temperature. We recommend either leaving one block at room temperature overnight to thaw before starting, or running it under warm water to thaw quickly on the morning of Section 3.

2.7. cDNA Quantification

The concentration and size distribution of the cDNA are measured with fluorescent dyes and capillary electrophoresis. The cDNA is then stored at 4°C for up to 48 hours or at -20°C for up to 3 months.

To quantify the cDNA:

1. Measure the concentration of each tube of purified cDNA from Section 2.6 with the Qubit dsDNA HS (High Sensitivity) Assay Kit according to the manufacturer's instructions. Record the concentration(s), which will be used in Section 3.
2. Assess the size distribution of each tube of purified cDNA with a High Sensitivity DNA Kit on the Agilent Bioanalyzer System or High Sensitivity D5000 ScreenTape and Reagents on the Agilent TapeStation System according to the manufacturer's instructions.



Safe stopping point: purified cDNA can be stored at 4°C for up to 48 hours or at -20°C for up to 3 months. Otherwise, proceed immediately to Section 3.

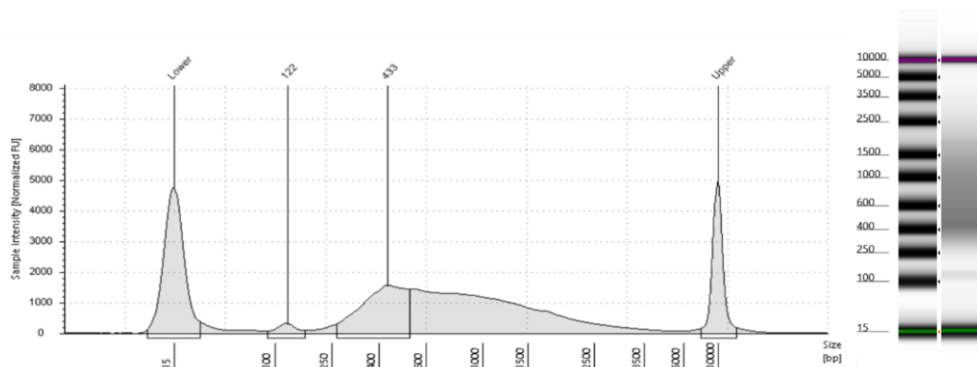

Figure 7: Expected post-amplification sublibrary cDNA size distribution. Example trace of Human cDNA run on a TapeStation.

Note: Samples may need to be diluted to be within the manufacturer's recommended concentration range. Typically, between a 1:3 to 1:10 dilution or 3-5 ng are appropriate.



Note: The traces above are representative of typical TapeStation cDNA traces. The shape and prominence of the trace is dependent on cell type, sublibrary size, and amount of DNA loaded into the TapeStation. Sublibraries with minor deviations can still produce high quality data.

Section 3: Sequencing Library Preparation

3.0. cDNA Normalization (Optional)

Prior to starting Section 3, cDNA can optionally be normalized to ensure that all sublibraries fall within the same amplification condition. It is advantageous to have all sublibraries use the same amplification condition because Section 3 processing occurs in a 96 well PCR plate instead of PCR strip tubes. The program uses nuclease free water on Deck B2 to normalize amplified cDNA from tube strip(s) on Deck B.

If choosing NOT to normalize amplified cDNA:

Manually prepare Diluted cDNA in columns 1 and 2 of a Semi-Skirted 96 Well PCR Plate as follows to a final volume of 35 μ L and store on ice. Store any remaining purified cDNA at -20°C .

DILUTED cDNA	
Purified cDNA	10 μ L
Nuclease-free water	25 μ L
Total Volume	35 μ L

To normalize amplified cDNA:

1. Gather the following items and handle as indicated below:

ITEM	SOURCE	QTY	HANDLING AND STORAGE
D-ONE Pipetting Module 1-Ch, 5-1250 μ L	INTEGRA Component	1	
Tip Deck for D-ONE Pipetting Module	INTEGRA Component	1	
Parse Metal Cold Block	Parse	1	
HEATMAG with 96 Well Adapter	INTEGRA Component	1	
Semi-Skirted 96 Well PCR Plate	Consumables	1	
125 μ L Tip Rack	INTEGRA	1	
1250 μ L Tip Rack	INTEGRA	1	
Nuclease free water	Reagents and Consumables		

2. If frozen, thaw the amplified cDNA and store it on ice.
3. Download the Parse Biosciences Evercode Mega/WT Integra Normalization file. The most current version can be found on the [Parse Biosciences Customer Support Suite](#).
4. Obtain recorded cDNA concentrations from Section 2.7.
5. Fill out the following cells of the Parse Biosciences Evercode Mega/WT Integra Normalization v1.0.xlsm. Target sample volume should be around 10 μ L (Figure 8).
 - a. Sample
 - b. Source Well
 - c. Concentration (ng/ μ L)
 - d. Library Input (ng)



Note: If any parameter is out of range, the cells will turn pink in color and/or an error message will appear. Be sure to address and adjust worksheet input values appropriately before continuing.

Parse Biosciences
700 Dexter Ave
Suite 600
Seattle, WA 98109



Support Suite: support.parsebiosciences.com
Email: support@parsebiosciences.com
WT Mega – Version 2.0

Evercode WT cDNA Normalization Loading Table

- For more details on using this cDNA Normalization Loading Table, see the Important Guidelines section of the User Manual

This sheet should be filled out prior to starting Section 3.

Step	Instructions
1	Ensure Macros are enabled.
4	Input your sample names.
6	Input source wells location.
6	Input destination well location.
6	Input cDNA concentration in ng/ μ L.
7	Input total ng library prep input.
8	CRITICAL: Ensure Sample Volume (μ L) is between 4 to 25 μ L. Larger sample volume leads to higher sublibrary complexity.
9	Open the "Integra Loading Table" sheet. Click on the "Generate a cDNA Normalization Worklist for Import into VIALAB" to generate the worklist file.

Number of PCR Cycles	
cDNA Input (ng)	PCR Cycles
10 - 24	13
25 - 49	12
50 - 99	11

Number of PCR Cycles	
cDNA Input (ng)	PCR Cycles
100 - 299	10
300 - 999	8
1,000 or more	7

Sample	Source Well	Destination Well	Conc. (ng/ μ L)	Library Input (ng)	Sample Volume (μ L)	Diluent Volume (μ L)
a	A1	A1	10.28	339	33.0	2.0
b	B1	B1	9.64	100	10.4	24.6
c	C1	C1	3.96	100	25.3	9.7
d	D1	D1	7.26	100	13.8	21.2
e	E1	E1	3.82	100	26.2	8.8
f	F1	F1	8.78	100	11.4	23.6
g	G1	G1				
h	H1	H1				
i	A2	A2	7.74	100	12.9	22.1
j	B2	B2	7.02	100	14.2	20.8
k	C2	C2	5.18	100	19.3	15.7

Figure 8: Evercode WT Mega cDNA normalization loading table.

- Navigate to the "INTEGRA Loading Table" tab on the excel sheet, and click on "Generate a cDNA Normalization Worklist for Import". Save the generated CSV file (called Section3NormWTWorksheet_xxxxxxx_xxxxxxx.csv) (Figure 9).

SampleID	SourceDeckPosition	SourceWell	TargetDeckPosition	TargetWell	TransferVolume [µl]	TipType
a	B2	F2	C1	A1	2	125
b	B2	F2	C1	B1	24.6	125
c	B2	F2	C1	C1	9.7	125
d	B2	F2	C1	D1	21.2	125
e	B2	F2	C1	E1	8.8	125
f	B2	F2	C1	F1	23.6	125
i	B2	F2	C1	A2	22.1	125
j	B2	F2	C1	B2	20.8	125
k	B2	F2	C1	C2	15.7	125
l	B2	F2	C1	D2	27.7	125
a	B1	A1	C1	A1	33	125
b	B1	B1	C1	B1	10.4	125
c	B1	C1	C1	C1	25.3	125
d	B1	D1	C1	D1	13.8	125
e	B1	E1	C1	E1	26.2	125
f	B1	F1	C1	F1	11.4	125
i	B1	A2	C1	A2	12.9	125
j	B1	B2	C1	B2	14.2	125
k	B1	C2	C1	C2	19.3	125
l	B1	D2	C1	D2	7.3	125

Generate a cDNA Normalization Worklist for Import

Figure 9: Generated cDNA normalization worklist.

- Open the VIALAB program **MG S3 St0 V3 DONE_5** and navigate to the "Method" section. In the "O2 Worklist", under the "Worklist and Volumes" tab, import the "Section3NormWTWorksheet_xxxxxxx_xxxxxxx.csv" worklist file generated in the previous step. The "Import" button is located in the upper left of the Worklist and Volumes tab (Figure 10).

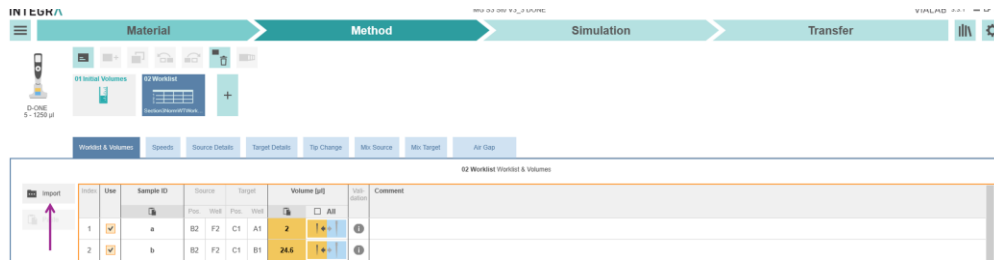
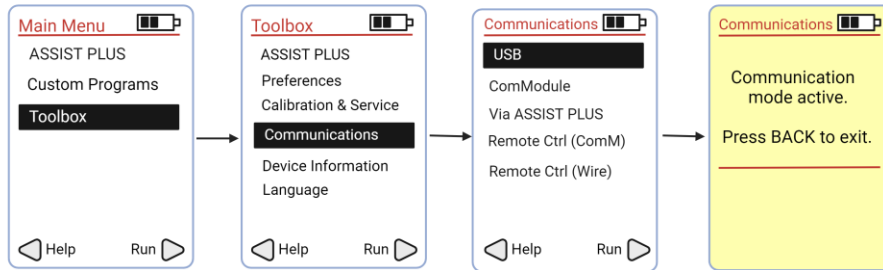

Figure 10: VIALAB worklist generation for diluent volumes using O2 Worklist.

8. Save and transfer your program to your D-ONE Pipetting Module (1-Ch, 5-1250 μ L) as follows:
 - a. Connect your computer with the D-ONE Pipette using Communication/Charging.
 - b. Follow the instructions on the pipette menu, as shown in the diagram below:



- c. In the VIALAB software on your computer, select "Transfer".
- d. Confirm that the pipette has been recognized by the software. Click "Send to pipette". An audible signal will indicate the successful upload of the **MG S3 St0 V3_5** program to the D-ONE Pipette.
- e. Disconnect the cable and proceed with the protocol on the INTEGRA ASSIST PLUS platform.
- f. A program named **MG S3 St0 V3_5** will be found on your pipette.



CRITICAL! Delete any previous scripts from the D-ONE pipette to avoid running incorrect scripts.

9. Set up the deck following the hardware configuration below.



10. Set up the deck layout Deck Configuration below:

- Briefly vortex and centrifuge the amplified cDNA and place on the Parse Metal Cold block on Deck B, column 1, left and right.
- Fill a clean 2 mL tube with 1.8 mL nuclease-free water and place on the Parse Metal Cold Block on Deck B, column 2 position 12.
- Place a clean semi-skirted plate on the HEATMAG with 96 Well Adapter on Deck C.

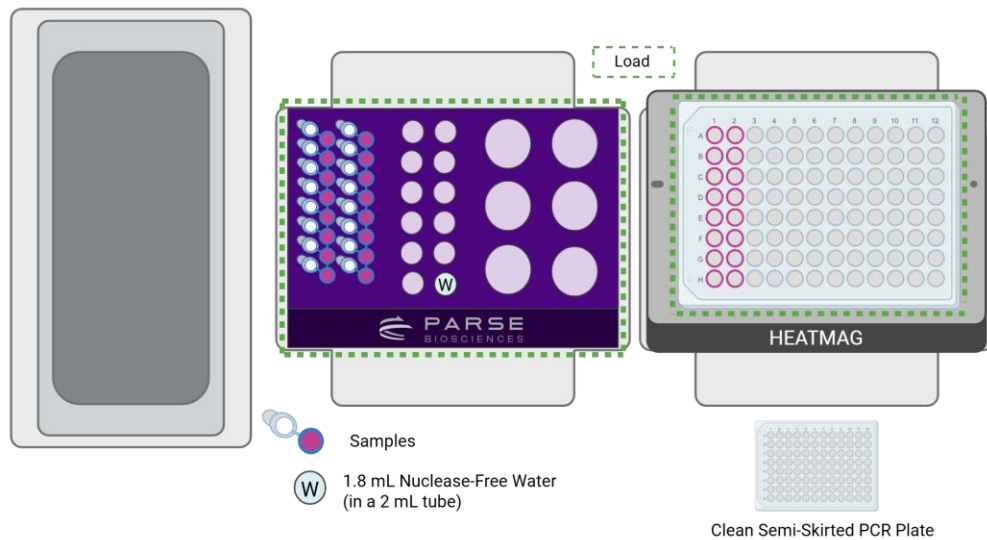

11. If needed, change the pipette:

- Remove the VOYAGER 8-Ch 5-125 μ L Pipette and corresponding Tip Deck. Ensure it is disconnected by pressing the back button until the main menu is displayed.
- Replace it with D-ONE Pipetting Module 1-Ch, 5-1250 μ L Pipette and corresponding Tip Deck. Ensure the tip deck and tip boxes are securely positioned by pressing them down firmly until they click into place. Remove the tip box lids prior to starting the program.

12. Select and run program **MG S3 St0 V3_5** following the diagram below.



13. At the conclusion of the run:

- a. The remaining cDNA samples from Deck B, column 1 left can be stored at -20°C .
- b. Store the normalized cDNA sample plate on Deck C on ice.

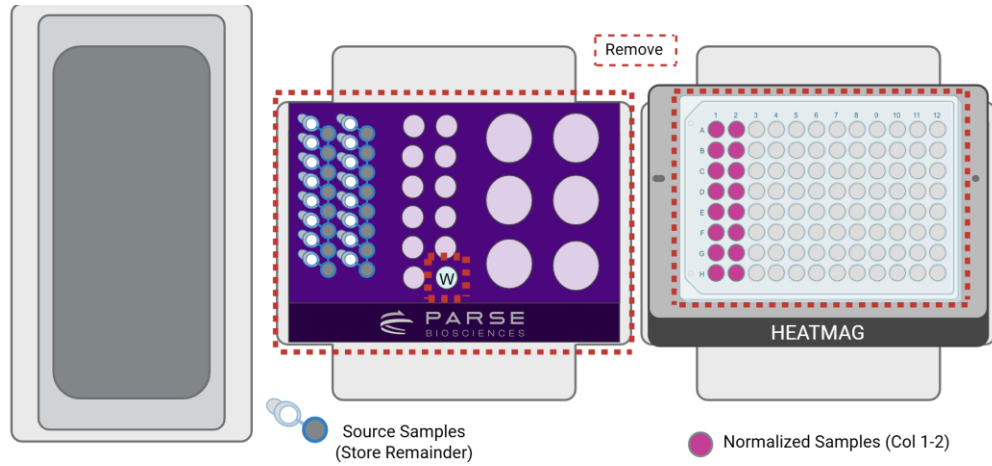

3.1. SPRI Bead Plating

The SPRI beads are aliquoted to be used throughout all of Section 3. Aliquots can then be quickly accessed via multichannel pipette when needed. SPRI beads should be kept at room temperature.

1. Gather the following components and reagents:

ITEM	SOURCE	QTY	HANDLING AND STORAGE
D-ONE Pipetting Module 1-Ch, 5-1250 μ L	INTEGRA Component	1	
Tip Deck for D-ONE Pipetting Module	INTEGRA Component	1	
Parse Metal Cold Block	Parse	1	
24 mm Labware Pedestal	INTEGRA Component	1	
Semi-Skirted 96 Well PCR Plate	Consumables	1	
2 mL tube	Consumables	2	
125 μ L Tip Rack	INTEGRA	1	
1250 μ L Tip Rack	INTEGRA	1	
SPRI Beads	Consumables and Reagents		

2. If not connected already, connect the D-ONE Pipetting Module 1-Ch, 5-1250 μ L Pipette and corresponding Tip Deck. Ensure the tip deck and tip boxes are securely positioned by pressing them down firmly until they click into place. Remove the tip box lids prior to starting the program.
3. Load the 24 mm Labware Pedestal on Deck A.
4. If not connected already, connect the HEATMAG on Deck C.

5. Move the Parse Metal Cold Block onto the 24 mm Labware pedestal on Deck A. The deck layout should correspond to the configuration below:



6. Ensure the following are loaded, using the deck configuration below:
 - a. Deck A column 1:
 - i. Pos 5 and 6: two 2 mL tubes with **1,700 µL** fully resuspended SPRI beads each. If the beads have been sitting overnight, they should be manually resuspended prior to loading them on the Parse Metal Cold Block.
 - b. Deck C: clean semi-skirted 96 well PCR plate.

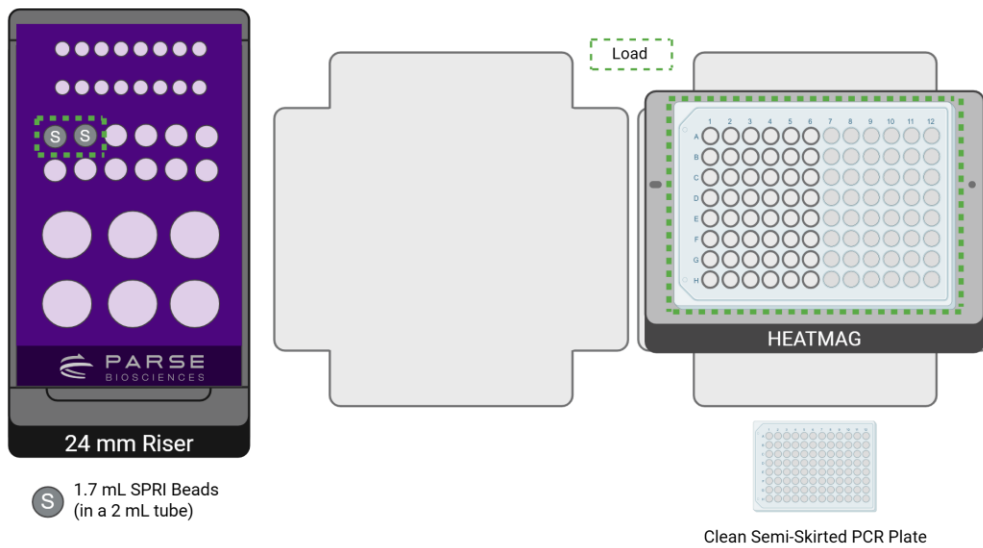

7. Select and run the program **MG S3 St1 V3_5** following the diagram below.

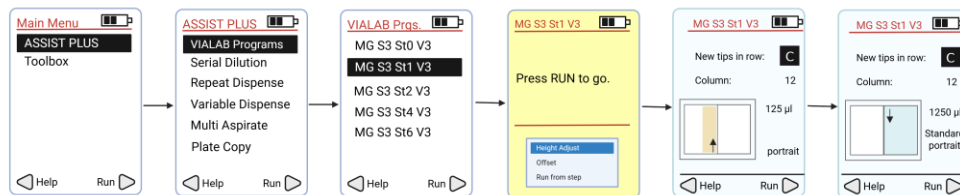

8. Wait for the program to complete.
9. Start thawing the ThermoChromic PCR Cold Block with Riser stored at -20°C that will be used in the next step.
10. At the conclusion of the run:
 - a. Leave the D-ONE pipette connected to the instrument. If proceeding immediately to Section 3.2, leave the plate with beads on the HEATMAG. Otherwise, remove the plate with beads and keep it aside at room temperature.
 - b. Discard the used tubes on Deck A. Remove and store the Parse Metal Cold Block on ice.

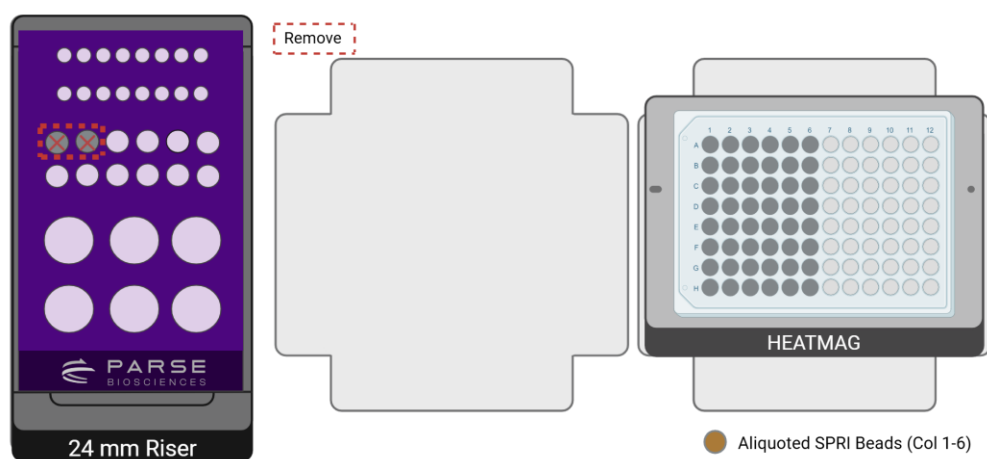

3.2. Fragmentation Mix Creation and Plating

The program makes the Fragmentation Mix and aliquots out the mix such that it can be easily pipetted into sublibraries using the multichannel pipette.

1. Gather the following components and reagents:

ITEM	SOURCE	QTY	HANDLING AND STORAGE
D-ONE Pipetting Module 1-Ch, 5-1250 μ L	INTEGRA Component	1	
Tip Deck for D-ONE Pipetting Module	INTEGRA Component	1	
Parse Metal Cold Block	Parse	1	
24 mm Labware Pedestal	INTEGRA Component	1	
Thermochromic PCR Cold Block	Parse	1	Pull the Thermochromic PCR Cold Block with riser from the -20°C freezer and leave them at room temperature for 10 minutes prior to use.
Thermochromic PCR Cold Block Riser	Parse	1	
HEATMAG with 96 Well Adapter	INTEGRA Component	1	
Semi-Skirted 96 Well PCR Plate	Consumables	1	
125 μ L Tip Rack	INTEGRA	1	
1250 μ L Tip Rack	INTEGRA	1	
1.5 mL tube	Consumables	1	
● Fragm/End Prep Buffer	-20°C Reagents	1	Thaw at room temperature then store on ice.
● Fragm/End Prep Enzymes	-20°C Reagents	1	Place directly on ice. Briefly centrifuge before use.

2. If not already connected, connect the D-ONE Pipetting Module 1-Ch, 5-1250 μ L Pipette and corresponding Tip Deck. Ensure the tip deck and tip boxes are securely positioned by pressing them down firmly until they click into place. Remove the tip box lids prior to starting the program.
3. If not done already, remove both Thermochromic PCR Cold Block with Riser from -20°C and thaw at room temperature for **10 minutes**.

4. Place the Thermochromic PCR Cold Block with Riser on Deck B.
5. Place the cooled Parse Metal Cold Block on Deck A. the deck layout should correspond to the configuration below:

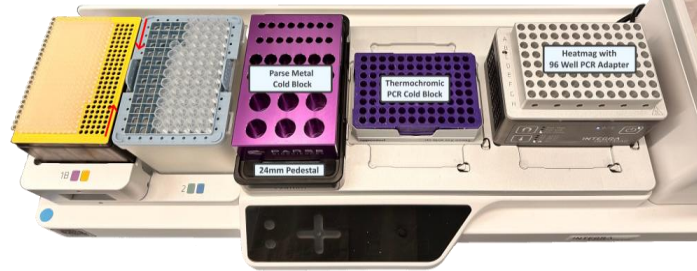

6. Place the following components using the deck configuration below:
 - a. Deck A, column 1:
 - i. Pos 1: a clean 1.5 mL tube.
 - ii. Pos 2: ● Fragm/End Prep Enzymes.
 - iii. Pos 3: ● Fragm/End Prep Buffer.
 - b. Transfer the cDNA sample plate stored on ice from Section 3.0 to the Thermochromic PCR Cold Block on Deck B with A1 in the upper left corner, pressing firmly to ensure the plate is fully seated.

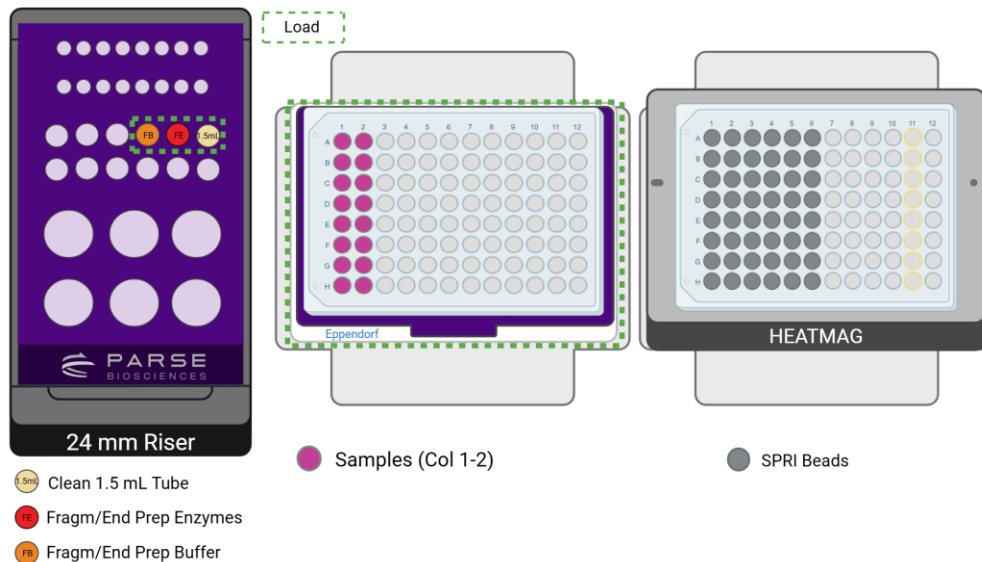

7. Remove the reagent caps, then select and run the program **MG S3 St2 V3_5** following the diagram below.

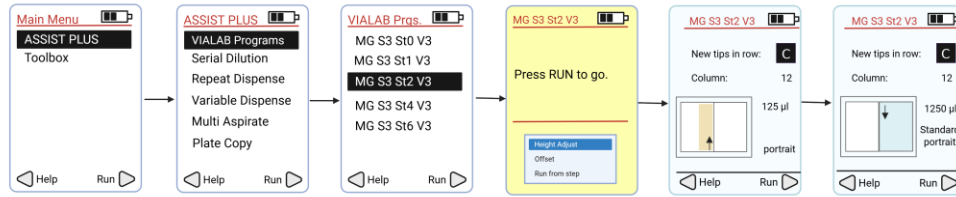

8. Follow the program prompts for manual intervention:

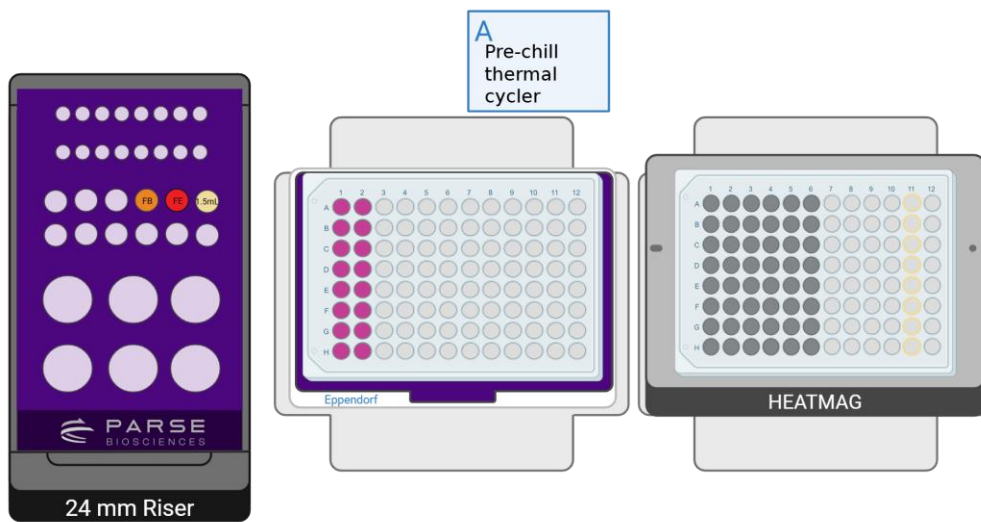

a. Start the Fragmentation and End Prep program on the thermocycler to pre-chill, ensuring that Step 1 of the cycling program is set to 4°C, so it will be at the correct temperature when needed during Section 3.3.6. Press "Run" on the pipette to continue.

FRAGMENTATION AND END PREP		
Run Time	Lid Temperature	Sample Volume
40 min	70°C	50 µL
Step	Time	Temperature
1	Hold	4°C
2	10 min	32°C
3	30 min	65°C
4	Hold	4°C

9. At the conclusion of the run:
 - a. Discard the tubes on Deck A.
 - b. Keep all labware on Decks B and C as they will be used in the next step.
 - c. Remove the Parse Metal Cold Block from the Deck A, place it on ice, and proceed immediately to Section 3.3.

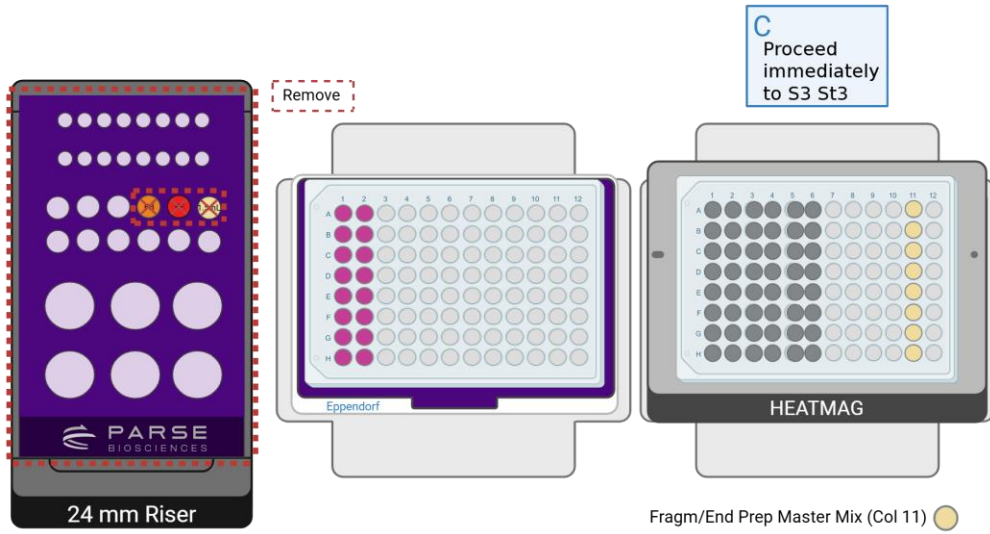

3.3. Fragmentation Mix Addition and Post-Fragmentation SPRI Cleanup

The program uses the VOYAGER multichannel pipette to add Fragmentation Mix to sublibraries. After the user runs the Fragmentation thermal cycling program, sublibraries are loaded back onto the ASSIST PLUS and a double-sided SPRI cleanup is carried out.

1. Gather the following components and reagents and set up the deck as indicated below:

ITEM	SOURCE	QTY	HANDLING AND STORAGE
VOYAGER Module 8-Ch, 5-1250 µL	INTEGRA Component	1	
Tip Deck for VOYAGER Pipetting Module	INTEGRA Component	1	
24 mm Labware Pedestal	INTEGRA Component	1	
Thermochromic PCR Cold Block	Parse	2	Pull the Thermochromic PCR Cold Block with riser from the -20°C freezer. Thaw one at room temperature for 10 minutes prior to use. Allow the second one to reach room temperature.
Thermochromic PCR Cold Block Riser	Parse	2	
HEATMAG with 96 Well Adapter	INTEGRA Component	1	
300 mL Reservoir Base	INTEGRA	1	
8 Row Reservoir	INTEGRA	1	
125 µL Tip Rack	INTEGRA	1	
Ethanol	Consumables and Reagents		
Nuclease-free water	Consumables and Reagents		



2. Prepare at least **8 mL** of 85% ethanol with nuclease-free water.
3. Place a clean 8 Row Reservoir on the 300 mL Reservoir Base on Deck A. The deck layout should correspond to the configuration below.

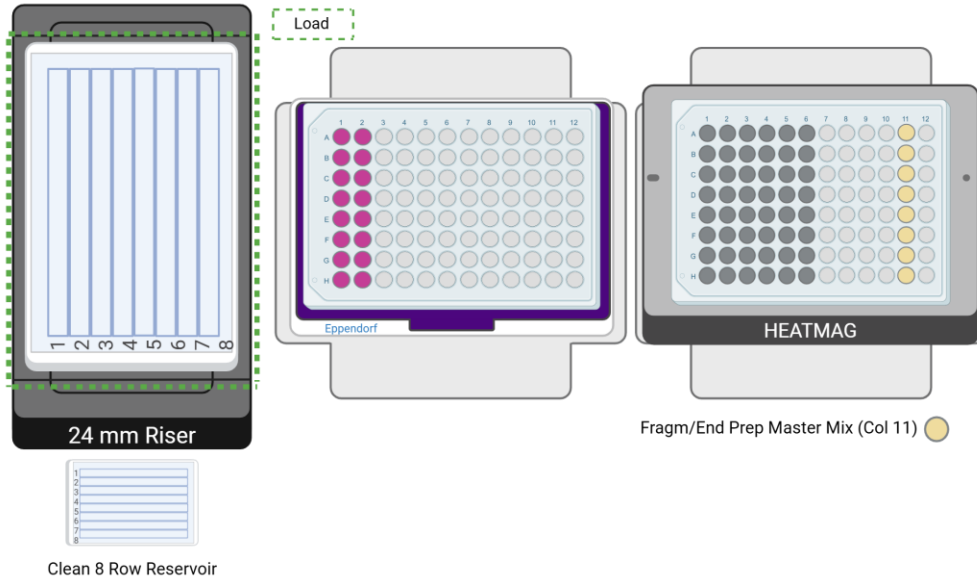

4. Change the pipette that is connected to the INTEGRA ASSIST PLUS:
 - a. Remove D-ONE Pipetting Module 1-Ch, 5-1250 μ L and corresponding Tip Deck. Ensure it is disconnected by pressing the back button until the main menu is displayed.
 - b. Replace it with VOYAGER 8-Ch 5-125 μ L Pipette and corresponding Tip Deck. Ensure the Tip Deck and tip box are securely positioned by pressing them down firmly until they click into place. Remove the tip box lid prior to starting the program.
5. Select and run the program **MG S3 St3 V3_5** following the diagram below.

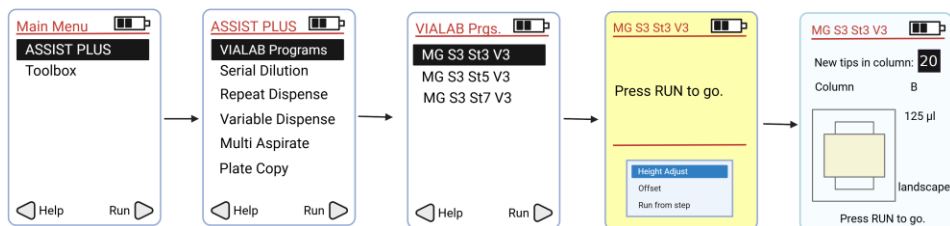

6. Press "Run" to continue the program. Follow the program prompts for manual intervention:
 - a. Remove the plate from Deck B and seal with a PCR plate seal. Place the sealed plate into the pre-cooled thermocycler from Section 3.2.8a.

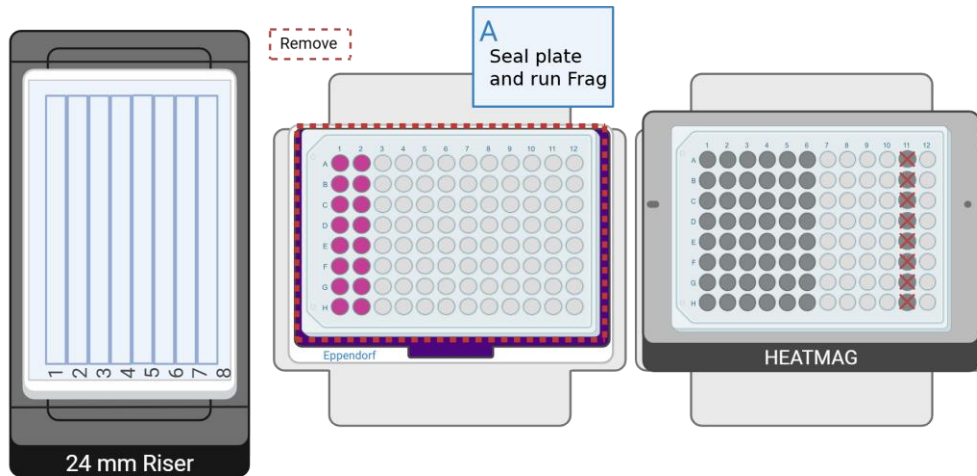

7. Ensure the thermocycler is cool prior to use and start the Fragmentation and End Prep program in the thermocycler pre-cooled in Section 3.2.8a. Skip the 4°C hold in Step 1 so the thermocycler proceeds to Step 2 of the Fragmentation and End Prep program.
8. While the thermocycler is running, press "Run" on the pipette to continue the program. Follow the program prompts for manual intervention:

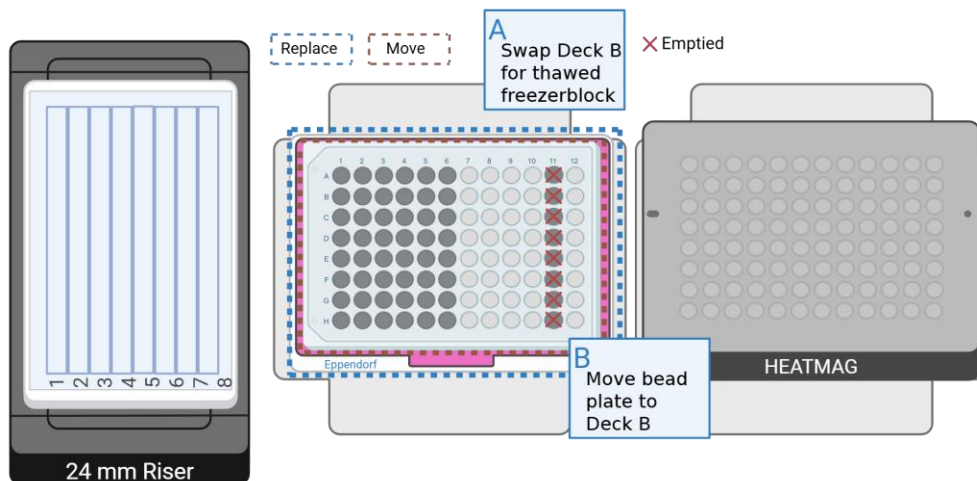

- a. Replace the frozen Thermochromic PCR Cold Block with riser with the one that has been brought to room temperature. A fully thawed Thermochromic PCR Cold block should look pink in color. Press "Run" to continue.

- b. Move the plate on Deck C onto the fully thawed Thermochromic PCR Cold Block on Deck B. Press "Run" on the pipette to continue.

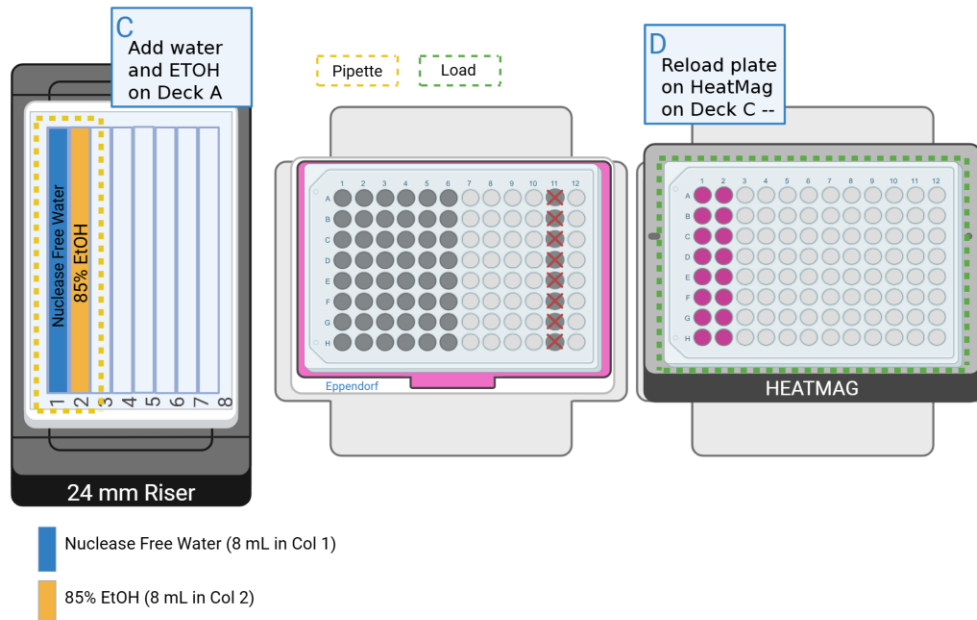

- c. With a P1000 pipette set to 1,000 μ L add:
- 8 mL** nuclease free water in lane **1** of the 8 Row Reservoir on Deck A.
 - 8 mL** 85% Ethanol in lane **2** of the 8 Row Reservoir on Deck A. Press "Run" to continue.
- d. When Fragmentation has completed and when prompted, load the sublibrary plate onto the HEATMAG on Deck C. Ensure the nuclease free water and the 85% Ethanol are evenly distributed within their rows.

9. At the conclusion of the run:

- Cover with a PCR plate seal and remove the 8 Row Reservoir on Deck A. Store at room temperature for later use.
- Keep all labware on Decks B and C. They will be used for the next step.

10. When the program is complete, continue to Section 3.4.

 Safe stopping point: The size-selected fragmented and end prepped DNA can be stored at 4°C for up to 18 hours or at -20°C for up to 2 weeks.

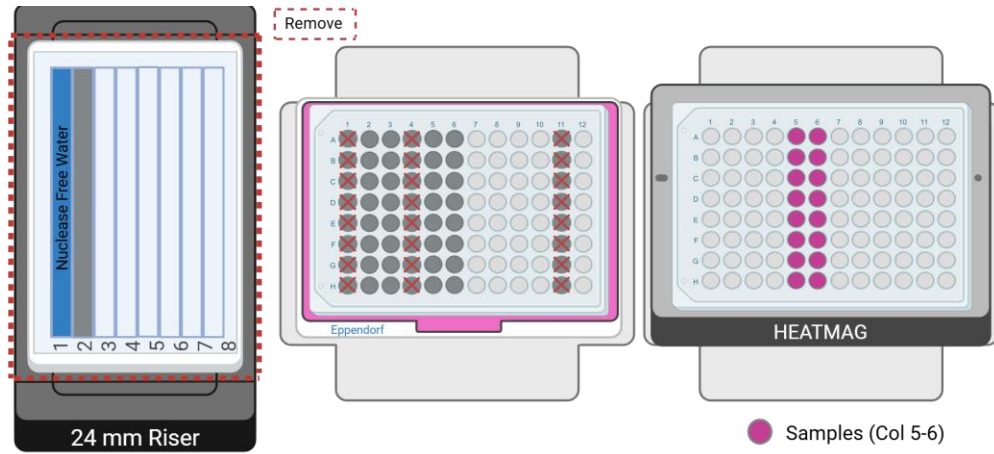

3.4. Ligation Mix Creation and Plating

The program prepares the Ligation Mix in a clean 1.5 mL tube, then dispenses it into column 10 of the semi-skirted 96-well plate on Deck B, allowing for easy pipetting into sublibraries using the multichannel pipette.

1. Gather the following components and reagents:

ITEM	SOURCE	QTY	HANDLING AND STORAGE
D-ONE Pipetting Module 1-Ch, 5-1250 μ L	INTEGRA Component	1	
Tip Deck for D-ONE Pipetting Module	INTEGRA Component	1	
Parse Metal Cold Block	Parse	1	
24 mm Labware Pedestal	INTEGRA Component	1	
Thermochromic PCR Cold Block	Parse	1	Ensure the Thermochromic PCR Cold Block with riser is at room temperature before use.
Thermochromic PCR Cold Block Riser	Parse	1	
HEATMAG with 96 Well Adapter	INTEGRA Component	1	
125 μ L Tip Rack	INTEGRA	1	
1250 μ L Tip Rack	INTEGRA	1	
● Ligation Adapter	-20°C Reagents	1	Thaw at room temperature then place on ice. Mix by inverting 3x. Briefly centrifuge before use.
● Adapter Ligation Buffer	-20°C Reagents	1	
● Adapter Ligation Enzyme	-20°C Reagents	1	Place directly on ice. Briefly centrifuge before use.

2. Place the Parse Metal Cold Block on Deck A. The deck layout should correspond to the configuration below.

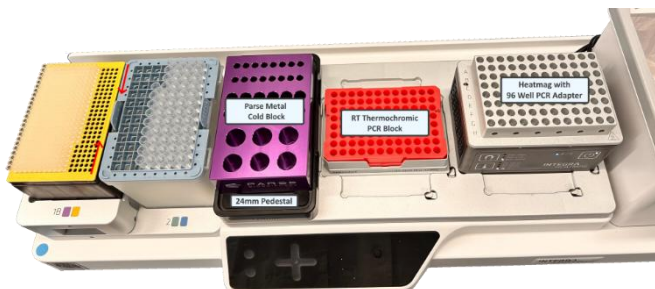

3. On the Parse Metal Cold Block place these components following the deck configuration below:

- a. Column 2:
 - i. Pos 7: a clean 1.5 mL tube.
 - ii. Pos 8: ● Ligation Adapter.
 - iii. Pos 9: ● Adapter Ligation Enzyme.
 - iv. Pos 10: ● Adapter Ligation Buffer.
 - v. Pos 11: a 1.5 mL tube filled with **400 µL** of nuclease free water.

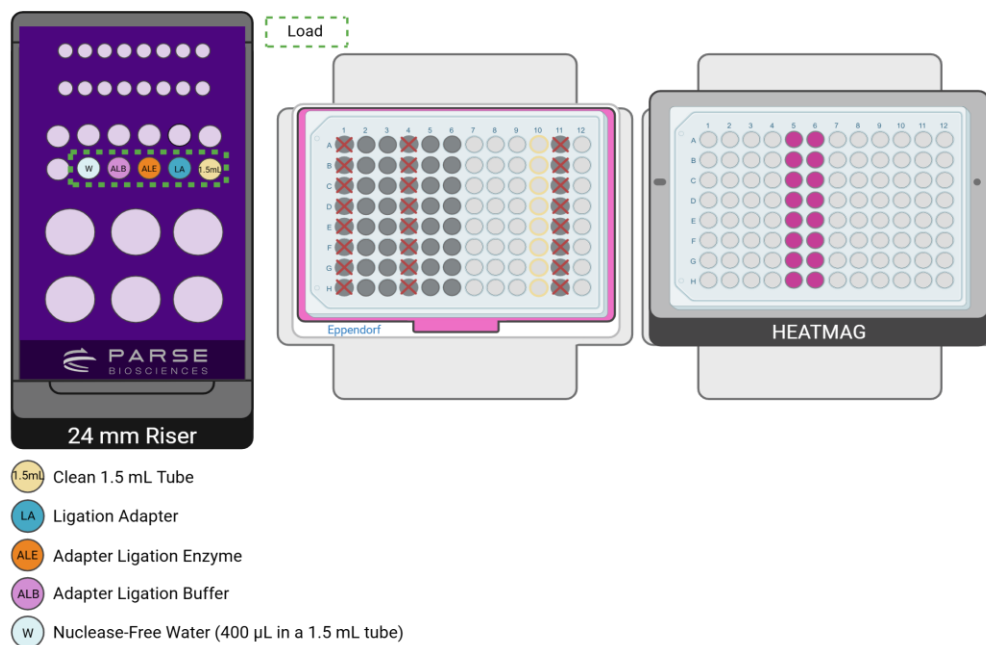

4. Change the pipette that is connected to the INTEGRA ASSIST PLUS:

- a. Remove the VOYAGER 8-Ch 5-125 µL Pipette and corresponding Tip Deck. Ensure it is disconnected by pressing the back button until the main menu is displayed.
- b. Replace it with D-ONE Pipetting Module 1-Ch, 5-1250 µL and corresponding Tip Deck. Ensure the tip deck and tip boxes are securely positioned by pressing them down firmly until they click into place. Remove the tip box lid prior to starting the program.

5. Remove the reagent caps, select and run the program **MG S3 St4 V3_5** following the diagram below.

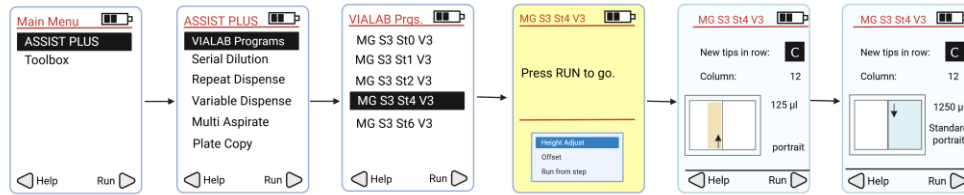

6. At the conclusion of the program:

- a. Remove the Parse Metal Cold Block from Deck A. Discard all the tubes.
- b. Keep all labware on Decks B and C. Proceed immediately to section 3.5.

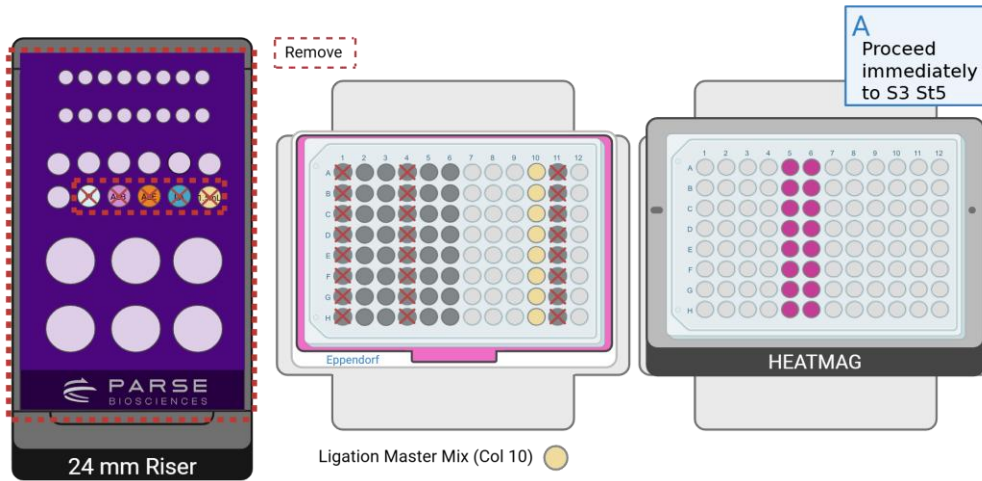

3.5. Ligation Master Mix Addition and Post-Ligation SPRI Cleanup

The program uses the VOYAGER multichannel pipette to add Ligation Mix to sublibraries. After the user runs the Ligation thermocycling program, sublibraries are loaded back onto the ASSIST PLUS and a single-sided SPRI cleanup is carried out.

1. Gather the following components and reagents:

ITEM	SOURCE	QTY	HANDLING AND STORAGE
VOYAGER Pipetting Module 8-Ch, 5-1250 μ L	INTEGRA Component	1	
Tip Deck for VOYAGER Pipetting Module	INTEGRA Component	1	
24 mm Labware Pedestal	INTEGRA Component	1	
Thermochromic PCR Cold Block	Parse	1	Ensure the Thermochromic PCR Cold Block with riser is at room temperature before use.
Thermochromic PCR Cold Block Riser	Parse	1	
HEATMAG with 96 Well Adapter	INTEGRA Component	1	
300 mL Reservoir Base	INTEGRA Component	1	
125 μ L Tip Rack	INTEGRA	1	
8 Row Reservoir	INTEGRA	1	
Ethanol	Consumables and Reagents		
Nuclease-free water	Consumables and Reagents		

2. Prepare at least **8 mL** of 85% ethanol with nuclease free water.

3. Load the 8 Row Reservoir stored at room temperature. The deck layout should correspond to the configuration below.

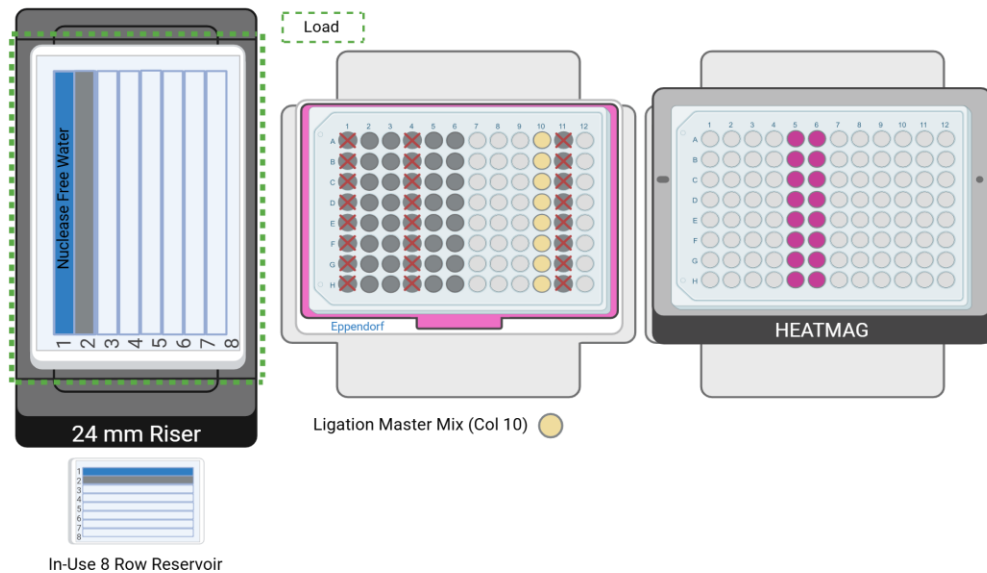

4. Change the pipette that is connected to the INTEGRA ASSIST PLUS:
 - a. Remove the D-ONE Pipetting Module 1-Ch, 5-1250 μ L and corresponding Tip Deck. Ensure it is disconnected by pressing the back button until the main menu is displayed.
 - b. Replace it with VOYAGER 8-Ch 5-125 μ L Pipette and corresponding Tip Deck. Ensure the tip deck and tip box are securely positioned by pressing them down firmly until they click into place. Remove the tip box lid prior to starting the program.

5. Navigate to the VIALAB programs on the Voyager Pipetting Module, select and run the program **MG S3 St5 V3_5** following the diagram below.

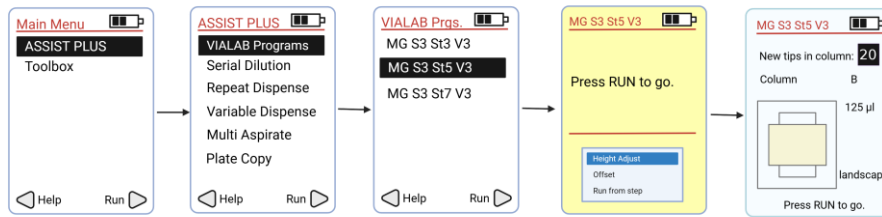

6. Press "Run" to continue the program. Follow the program prompts for manual intervention:

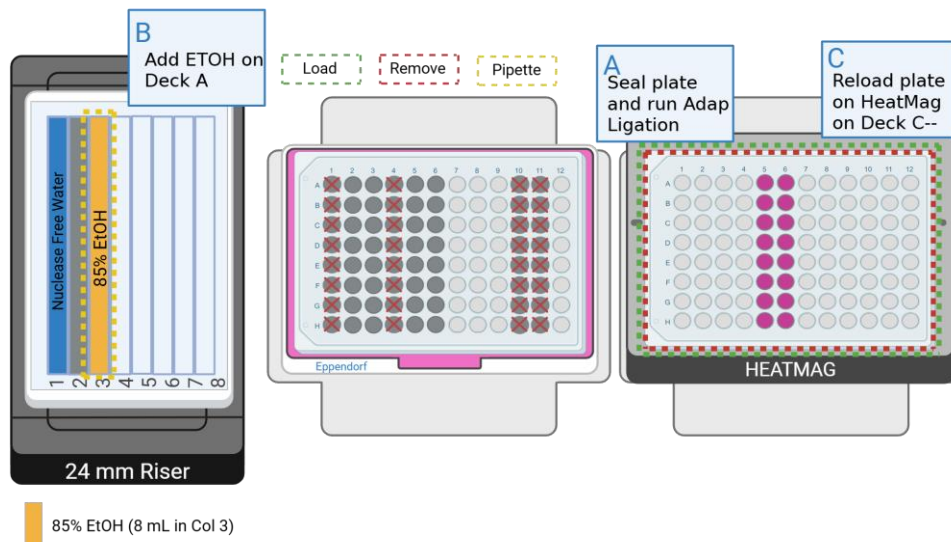

a. Seal the sample plate with a PCR plate seal on Deck C and place it into a thermocycler. Run the following program. Proceed to the next step while the program is still running.

ADAPTER LIGATION		
Run Time	Lid Temperature	Sample Volume
15 min	30°C*	100 µL
Step	Time	Temperature
1	15 min	20°C
2	Hold	4°C



Note: *If the thermocycler's lid can't reach the recommended temperature of 30°C, turn the lid heating off.

- c. With a P1000 pipette set to 1000 μ L, add **8 mL** 85% Ethanol to lane **3** of the 8 Row Reservoir on Deck A.
 - d. Upon thermocycling completion reload the sample plate onto the HEATMAG with 96 Well Adapter located on Deck C and remove the seal.
7. At the conclusion of the program:
- a. Cover with a PCR plate seal and remove the reagent reservoir on Deck A. Store at room temperature for later use.
 - b. Keep all labware on Decks B and C. Proceed to Section 3.6.

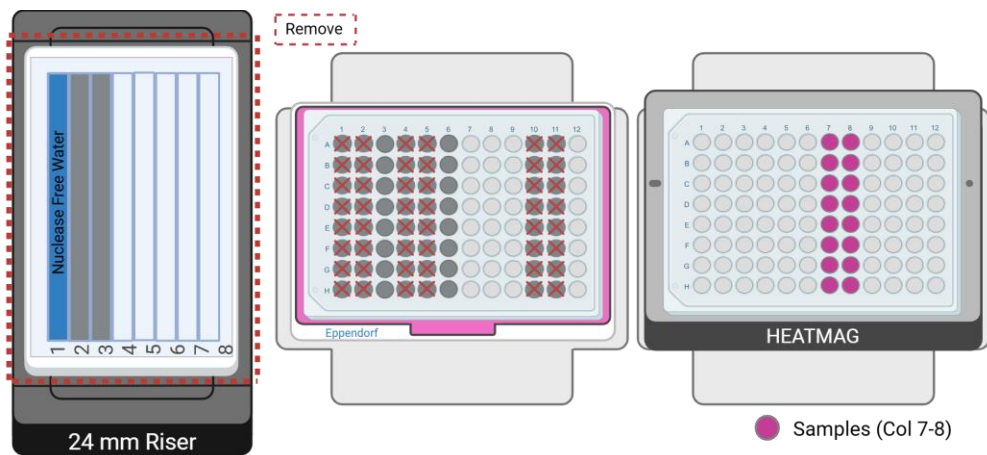

3.6. Barcoding Round 4

Program uses the pipette to aliquot out the Library Amp Mix such that it can be easily pipetted into sublibraries using the multichannel pipette. During this program, the user will manually add UDIs to sublibraries.

1. Gather the following components and reagents:

ITEM	SOURCE	QTY	HANDLING AND STORAGE
D-ONE Pipetting Module 1-Ch, 5-1250 μ L	INTEGRA Component	1	
Tip Deck for D-ONE Pipetting Module	INTEGRA Component	1	
Parse Metal Cold Block	INTEGRA Component	1	
24 mm Labware Pedestal	INTEGRA Component	1	
Thermochromic PCR Cold Block	Parse	1	Ensure the Thermochromic PCR Cold Block with riser is at room temperature before use.
Thermochromic PCR Cold Block Riser	Parse	1	
HEATMAG with 96 Well Adapter	INTEGRA Component	1	
125 μ L Tip Rack	INTEGRA	1	
1250 μ L Tip Rack	INTEGRA	1	
● Library Amp Mix	-20°C Reagents	1	Thaw at room temperature then place on ice. Mix by inverting 3x. Briefly centrifuge before use.
UDI Plate - WT	Parse reagents	1 sealed well per sublibrary	Thaw at room temperature then place on ice.

2. Load the Parse Metal Cold Block on the 24 mm Labware Pedestal on Deck A. The deck layout should correspond to the configuration below.



3. Place the ● Library Amp Mix in the Parse Metal Cold Block, column 1, position 4. The deck layout should correspond to the configuration below.

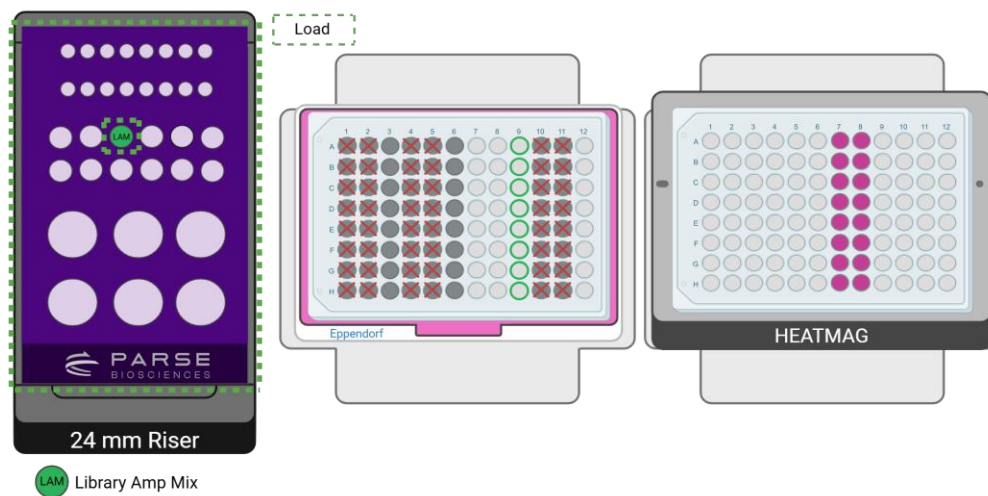

4. Change the pipette that is connected to the INTEGRA ASSIST PLUS:
 - a. Remove the VOYAGER 8-Ch 5-125 μ L Pipette and corresponding Tip Deck. Ensure it is disconnected by pressing the back button until the main menu is displayed.
 - b. Replace it with D-ONE Pipetting Module 1-Ch, 5-1250 μ L and corresponding Tip Deck. Ensure the tip deck and tip boxes are securely positioned by pressing them down firmly until they click into place. Remove the tip box lids prior to starting the program.

- Uncap the reagents caps, select and run the program **MG S3 St6 V3_5** following the diagram below.

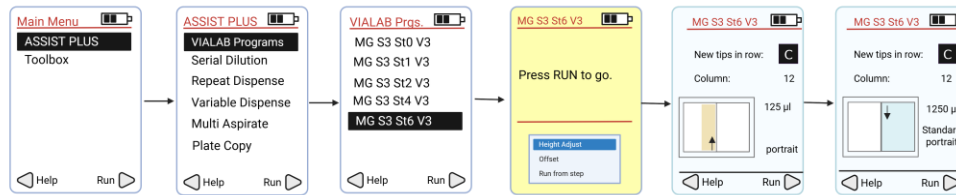

- While the program is running, centrifuge the thawed UDI Plate - WT at 100 x g for **1 minute**.
- Wipe the surface of the plate with 70% ethanol and allow it to dry.
- Orient the UDI Plate - WT with the notch on the bottom left as pictured below. For each sublibrary being processed, choose one unused well of the UDI Plate - WT and record the well position and number for each sublibrary.

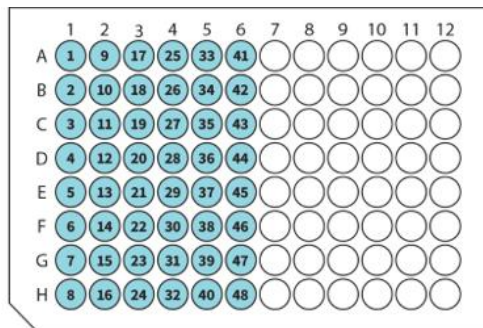

- With a multichannel P20, manually pierce the seal of the chosen wells of the UDI Plate - WT.
- When prompted**, with a multichannel P20 and new tips, manually mix by pipetting 5x then immediately transfer **4 µL** from a chosen unused well of the UDI Plate - WT to its corresponding sample well in columns 7 and 8 on Deck C.



CRITICAL! Only transfer primers from 1 well of the UDI Plate - WT to 1 well of adapter ligated DNA.

- If any unused wells remain in the UDI Plate - WT, store the plate at -20°C. Do not reuse pierced wells.
- Press "Run" to continue the program. At the conclusion of the run:
 - Remove all labware from Deck A.

b. Proceed immediately to Section 3.7.

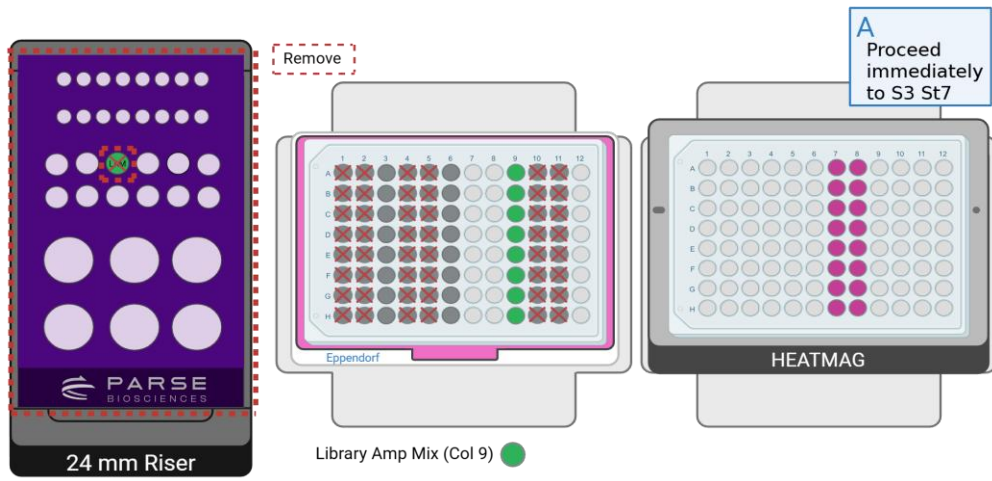

3.7. Library Amp Mix Addition and Size Selection

The program uses the VOYAGER multichannel pipette to add Library Amp Mix to the sublibraries. After the user runs the Indexing PCR thermocycling program, sublibraries are loaded back onto the ASSIST PLUS and a double-sided SPRI cleanup is carried out.

1. Gather the following components and reagents:

ITEM	SOURCE	QTY	HANDLING AND STORAGE
VOYAGER Pipetting Module 8-Ch 5-125 μ L	INTEGRA Component	1	
Tip Deck for VOYAGER Pipetting Module	INTEGRA Component	1	
24 mm Labware Pedestal	INTEGRA Component	1	
Thermochromic PCR Cold Block	Parse	1	Ensure the Thermochromic PCR Cold Block with riser is at room temperature before use.
Thermochromic PCR Cold Block Riser	Parse	1	
300 mL Reservoir Base	INTEGRA Component	1	
HEATMAG with 96 Well Adapter	INTEGRA Component	1	
125 μ L Tip Rack	INTEGRA	1	
8 Row Reservoir	INTEGRA	1	
Ethanol	Consumables and Reagents		
Nuclease-free water	Consumables and Reagents		



2. Prepare **8 mL** of 85% ethanol with nuclease-free water, set aside at room temperature for later use.

3. Load the 8 Row Reservoir stored at room temperature. The deck layout should correspond to the configuration below.

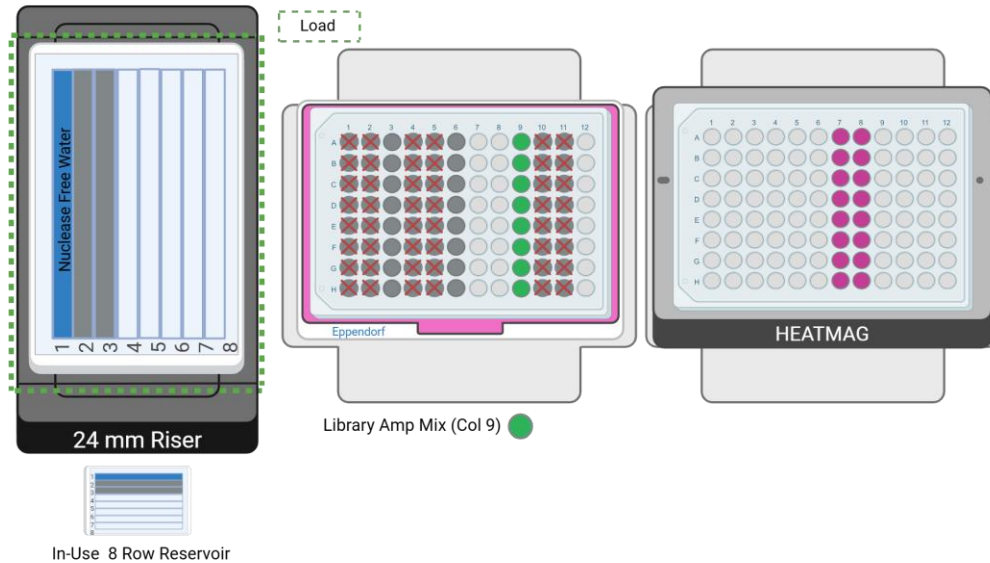

4. Change the pipette that is connected to the INTEGRA ASSIST PLUS:
 - a. Remove D-ONE Pipetting Module 1-Ch, 5-1250 μL and corresponding Tip Deck. Ensure it is disconnected by pressing the back button until the main menu is displayed.
 - b. Replace it with VOYAGER 8-Ch 5-125 μL Pipette and corresponding Tip Deck. Ensure the tip deck and tip box are securely positioned by pressing them down firmly until they click into place. Remove the tip box lid prior to starting the program.
5. Select and run the program **MG S3 St7 V3_5** following the diagram below.

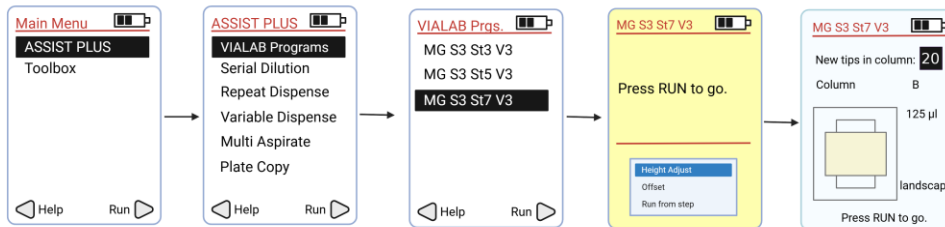

- While the program is running, determine the number of PCR cycles required for the Indexing PCR based on the amount of cDNA added to the fragmentation and end prep reaction.

NUMBER OF PCR CYCLES	
cDNA Input (ng)	PCR Cycles
10-24	13
25-49	12
50-99	11
100-299	10
300-999	8
1,000 or more	7

- Press "Run" to continue the program. Follow the program prompts for manual intervention:

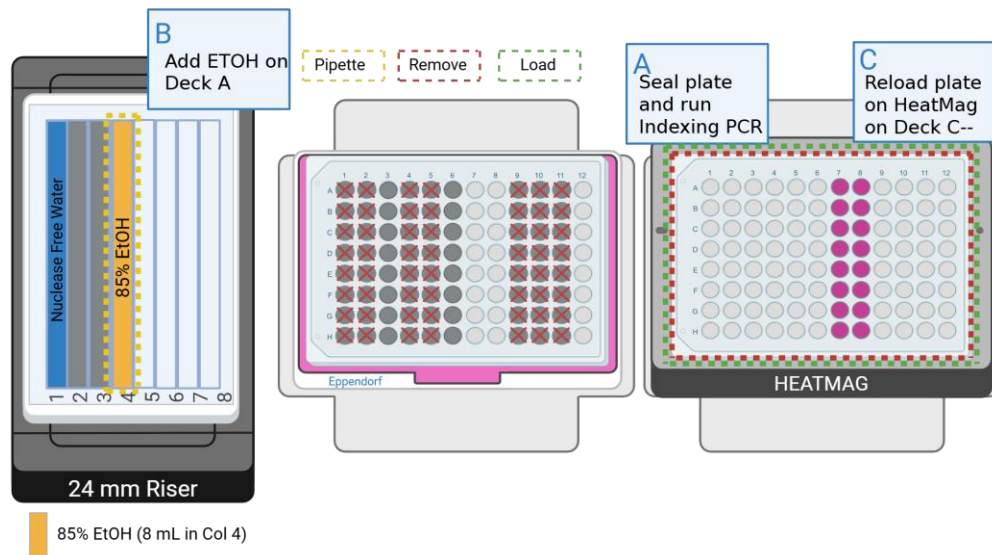

- a. Remove the sublibrary plate from the INTEGRA ASSIST PLUS, seal the sample plate on Deck C and place it into a thermocycler. Run the following program. When the Indexing PCR thermocycling program is complete, press "Run" to continue.

INDEXING PCR			
Run Time	Lid Temperature	Sample Volume	
~30 min	105°C	50 µL	
Step	Time	Temperature	Cycles
1	3 min	95°C	1
2	20 s	98°C	Varies, see table above
3	20 s	67°C	
4	1 min	72°C	
5	5 min	72°C	1
6	Hold	4°C	1

- b. With a P1000 pipette, add **8 mL** 85% Ethanol to row **4** of the 8 Row Reservoir on Deck A. Press "Run" to continue.
 - c. Reload the sample plate onto the HEATMAG with 96 Well Adapter on Deck C.
8. At the conclusion of the run:
- a. The sequencing libraries will be in columns 11 and 12 on Deck C. Sequencing libraries can be stored at -20°C for up to 3 months.
 - b. Discard the used 8 Row Reservoir on Deck A and their content.
 - c. Discard the used semi-skirted plate on Deck B.



Safe stopping point: Sequencing libraries can be stored at -20°C for up to 3 months.

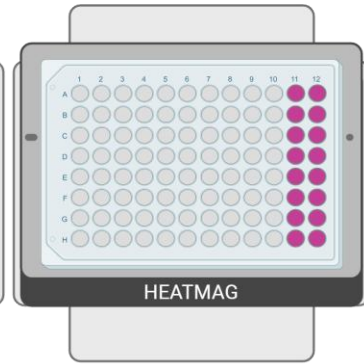
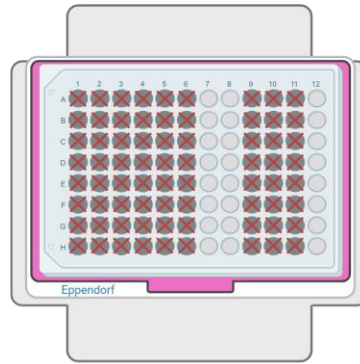
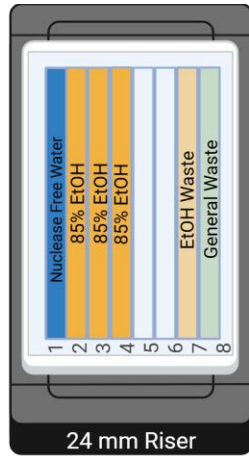

● Samples (Col 11-12)

3.8. Sequencing Library Quantification

The concentration and size distribution of the sequencing libraries are measured with fluorescent dyes and capillary electrophoresis. Sequencing libraries can be stored at -20°C for up to 3 months.

To quantify the sequencing libraries:

1. Measure the concentration of each purified sequencing library from Section 3.7 with the Qubit dsDNA HS (High Sensitivity) Assay Kit according to the manufacturer’s instructions.
2. Assess the size distribution of each purified sequencing library with a High Sensitivity DNA Kit on the Agilent Bioanalyzer System or High Sensitivity D1000 ScreenTape and Reagents on the Agilent TapeStation System according to the manufacturer’s instructions.

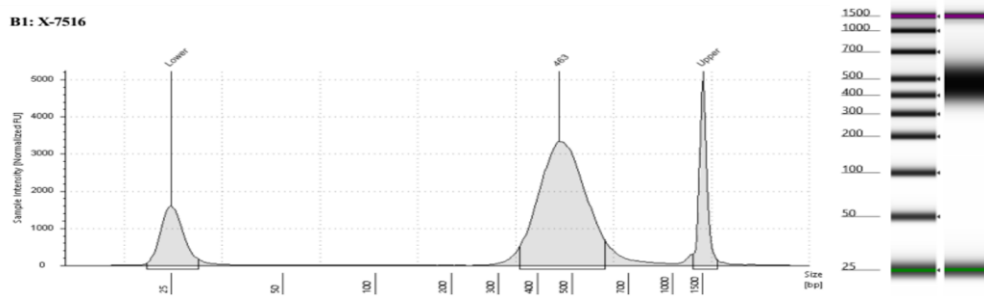

Figure 10: Expected Size Distribution before Illumina Sequencing. Example trace of Human DNA from indexed sublibraries run on a TapeStation.

Note: Samples may need to be diluted to be within the manufacturer's recommended concentration range. Typically, between a 1:3 to 1:10 dilution is appropriate.



Note: The traces above are representative of typical TapeStation of DNA from indexed sublibraries. There should be a peak between 400-500 bp. The prominence of the trace is dependent on the amount of DNA loaded into the TapeStation. Sublibraries with minor deviations can still produce high quality data.

Note: If using a Bioanalyzer, there may be an additional peak present. This typically occurs if products are overamplified, but it should not impact sequencing or data quality (assuming there is still a peak present at 400-500 bp). Do not use this additional peak when estimating amplicon size.

Appendices

Appendix A: Sequencing Information

We recommend a minimum sequencing depth of 20,000 reads per cell for whole transcriptome libraries. However, ideal sequencing depth is dependent on the sample type and experimental goals. For example, if trying to capture rare cell types in a heterogenous population, deeper sequencing is required. Alternatively, analyzing a homogenous population, more shallow sequencing may be appropriate.

Whole transcriptome sequencing libraries should be diluted and denatured according to the manufacturer’s instructions for the relevant sequencing instrument. If using the Illumina platform, we strongly recommend adding 5% PhiX for optimal sequencing quality.

Details of the final whole transcriptome sequencing library structure are below.

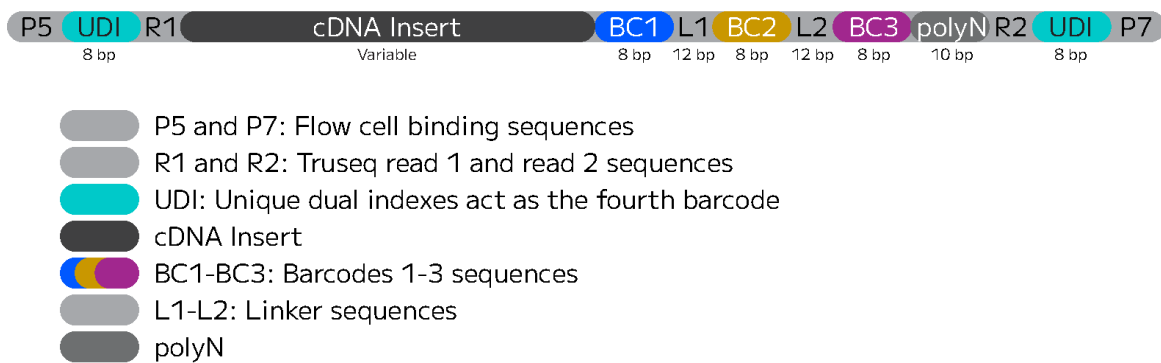

Figure 11: Whole transcriptome sequencing library structure.

Libraries should be sequenced with paired reads using the read structure in the table below. Read lengths longer than those recommended below are acceptable, but additional bases in read 2 are trimmed by the Parse Analysis Pipeline.

READ	FUNCTION	INSERT
Read 1	cDNA Insert	64
i7 Index (Index 1)	Barcode 4 / UDI	8
i5 Index (Index 2)	Barcode 4 / UDI	8
Read 2	Barcodes 1-3	58

For the sequencing BCR libraries please refer to the Evercode BCR User Manual.

The fourth barcode that tags each sublibrary act as a standard Illumina i7 and i5 indexes. Please refer to the following table to demultiplex the whole transcriptome libraries.

Sublibrary Index ID	Well Position	i7 Forward Sequence	i5 Reverse Complement Sequence	i5 Forward Sequence
UDI_Plate_WT_1	A1	CAGATCAC	ATGTGAAG	CTTCACAT
UDI_Plate_WT_2	B1	ACTGATAG	GTCCAACC	GGTTGGAC
UDI_Plate_WT_3	C1	GATCAGTC	AGAGTCAA	TTGACTCT
UDI_Plate_WT_4	D1	CTTGTAAT	AGTTGGCT	AGCCAACT
UDI_Plate_WT_5	E1	AGTCAAGA	ATAAGGCG	CGCCTTAT
UDI_Plate_WT_6	F1	CCGTCCTA	CCGTACAG	CTGTACGG
UDI_Plate_WT_7	G1	GTAGAGTA	CATTCATG	CATGAATG
UDI_Plate_WT_8	H1	GTCCGCCT	AGATACGG	CCGTATCT
UDI_Plate_WT_9	A2	GTGAAACT	TACAGACT	AGTCTGTA
UDI_Plate_WT_10	B2	TCATTCCT	AATGCCTG	CAGGCATT
UDI_Plate_WT_11	C2	GGTAGCAT	TGCTTGCC	GGCAAGCA
UDI_Plate_WT_12	D2	ACTTGATC	TTTGGGTG	CACCCAAA
UDI_Plate_WT_13	E2	ATGAGCAT	GAATCTGA	TCAGATTC
UDI_Plate_WT_14	F2	GCGCTATC	CGACTGGA	TCCAGTCG
UDI_Plate_WT_15	G2	TGACCAGT	ACATTGGC	GCCAATGT
UDI_Plate_WT_16	H2	TATAATCA	ACCACTGT	ACAGTGGT
UDI_Plate_WT_17	A3	CAAAAGTC	CGGTTGTT	AACAACCG
UDI_Plate_WT_18	B3	CGATGTCA	CATGAGGA	TCCTCATG
UDI_Plate_WT_19	C3	CTCAGAGT	TGGAGAGT	ACTCTCCA
UDI_Plate_WT_20	D3	TAATCGAC	TGACTTCG	CGAAGTCA
UDI_Plate_WT_21	E3	CATTTTCT	GGAAGGAT	ATCCTTCC
UDI_Plate_WT_22	F3	CTATACTC	TGTTGAG	CTCGAACA
UDI_Plate_WT_23	G3	CACTCACA	AAGGCTGA	TCAGCCTT
UDI_Plate_WT_24	H3	CTCGAACA	CTCGAGTG	CACTCGAG
UDI_Plate_WT_25	A4	CTCTATCG	ATCGGTGG	CCACCGAT
UDI_Plate_WT_26	B4	TCCTCATG	AGGTCTTG	CAAGACCT
UDI_Plate_WT_27	C4	AACAACCG	AGGAAGCG	CGCTTCTT
UDI_Plate_WT_28	D4	GCCAATGT	ACATGTGT	ACACATGT
UDI_Plate_WT_29	E4	TGGTTGTT	ATACAGTT	AACTGTAT
UDI_Plate_WT_30	F4	TCTGCTGT	ATCGCCTT	AAGGCGAT
UDI_Plate_WT_31	G4	TTGGAGGT	TTCGACGC	GCGTCGAA
UDI_Plate_WT_32	H4	TCGAGCGT	TGTCGTTC	GAACGACA
UDI_Plate_WT_33	A5	TGCGATCT	TCCATAGC	GCTATGGA
UDI_Plate_WT_34	B5	TTCCTGCT	TAAGTGTC	GACACTTA

Sublibrary Index ID	Well Position	i7 Forward Sequence	i5 Reverse Complement Sequence	i5 Forward Sequence
UDI_Plate_WT_35	C5	TTCCATTG	CTGGCATA	TATGCCAG
UDI_Plate_WT_36	D5	TAACGCTG	CTGAGCCA	TGGCTCAG
UDI_Plate_WT_37	E5	TTGGTATG	CTCAATGA	TCATTGAG
UDI_Plate_WT_38	F5	TGAACTGG	CGCATACA	TGTATGCG
UDI_Plate_WT_39	G5	TCCAGTCG	CCGAAGTA	TACTTCGG
UDI_Plate_WT_40	H5	TGTATGCG	CCAGTTCA	TGAACTGG
UDI_Plate_WT_41	A6	TGGCTCAG	CAGCGTTA	TAACGCTG
UDI_Plate_WT_42	B6	TATGCCAG	CAATGGAA	TTCCATTG
UDI_Plate_WT_43	C6	GGTTGGAC	ATCCTGTA	TACAGGAT
UDI_Plate_WT_44	D6	GACACTTA	AGCAGGAA	TTCCTGCT
UDI_Plate_WT_45	E6	GAACGACA	ACGCTCGA	TCGAGCGT
UDI_Plate_WT_46	F6	AAGGCGAT	ACAGCAGA	TCTGCTGT
UDI_Plate_WT_47	G6	ATGCTTGA	ACAAGCTA	TAGCTTGT
UDI_Plate_WT_48	H6	AGTATCTG	CATCAAGT	ACTTGATG

Appendix B: Pipetting Programs

Section 1.1. Sample Normalization

MG S1 St1 V3_5

STEPS	ACTION	DURATION
1	Initial Volumes	
2	Dilute Cells	40 min
3	"Thaw R1 Plate" message	

Section 1.2. Round 1 Plate Loading and Pooling

MG S1 St2 V3_5

STEPS	ACTION	DURATION
1	Initial Volumes	
2	Transfer Diluted Fixed Sample to Round 1 Barcoding Plate (14 μ L/well)	7 min
3	"Remove R1 plate on Deck C" message	
4	"Remove labware on Deck B" message	
5	"Move hardware on Deck B" message	
6	"Load R1 Plate on Deck B - -" message	
7	Volume Change	
8	Pool Cells into Row A (42 μ L/well)	1 min
9	Pool Cells into Row A (15 μ L/well)	1 min
10	Pool Cells into Row E (42 μ L/well)	1 min
11	Pool Cells into Row E (15 μ L/well)	1 min

Section 1.3. Round 2 Ligation Preparation

MG S1 St3 V3_5

STEPS	ACTION	DURATION
1	Initial Volumes	
2	Pool row A into 10 mL Tube with 1000 μ L tips (117 μ L/well)	4 min
3	Pool row E into 10 mL Tube with 1000 μ L tips (117 μ L/well)	4 min
4	Pool row into 10 mL Tube with 125 μ L tips (10 μ L/well)	2 min
5	Add Spin Additive	30 sec
6	"Remove 10mL Tube from Deck C" message	
7	"Thaw R2 Plate" message	
8	"Load 10mL Tube on Deck C -" message	
9-16	Remove Supernatant (3.9 mL)	2 min
17	"Checkpoint: Supernatant Removed - - " message	
18-19	Resuspend Cell Pellet with Resuspension Buffer (2 mL)	1 min
20	Add R2 Ligation Enzyme to Buffer (20 μ L)	1 min
21	Mix Ligation Mix	1 min
22	Volume Change	
23	Transfer Cells to Ligation Mix (2.3 mL)	30 sec
24	Mix Cells in Ligation Mix	30 sec
25-28	Transfer Ligation Mix to Basin (~4,2 mL)	1.5 min
29-31	Mix Sample in Basin	30 sec

Section 1.4. Round 2 Ligation

MG S1 St4 V3_5

STEPS	ACTION	DURATION
1	Initial Volumes	
2-4	Mix samples in basins	1.5 min
5-12	Load Sample into Round 2 Plate (40 μ L/well)	8 min
13	"Remove R2 Plate for incubation" message	
14	"Replace the left basin liner" message	
15	"Load R2 plate on Deck B" message	
16	"Pipette R2 Stop in Deck A" message	
17	Volume Change	
18	Add R2 Stop (10 μ L/well)	5 min
19	"Remove R2 Plate for incubation" message	
20	"Replace right basin liner" message	
21	"Load R2 Plate on Deck B" message	
22-23	Pool R2 Plate to basin (65 μ L/well)	4 min

Section 1.5. Round 3 Ligation Preparation

MG S1 St5 V3_5

STEPS	ACTION	DURATION
1	Initial Volumes	
2	"Move basin to slanted holder" message	
3	"Load cell strainer on 10 mL tube" message	
4	"Thaw R3 Plate - -" message	
5	Wash basin mix	30 sec
6	Volume change	

STEPS	ACTION	DURATION
7-11	Strain cells/nuclei (6 mL)	2 min
12	"Move Basin Holder to Deck A" message	
13	"Remove cell strainer" message	
14	Labware change	
15	Add R3 Ligation Enzyme (20 μ L)	1 min
16	Mix Ligation Enzyme with sample	1.5 min
17	Volume change	
18-22	Transfer cells/nuclei to right basin (~6.04 mL)	2 min

Section 1.6. Round 3 Ligation

MG S1 St6 V3_5

STEPS	ACTION	DURATION
1	Initial Volumes	
2-4	Mix sample in basin	1.5 min
5-12	Add sample to Round 3 Plate (50 μ L/well)	8 min
13	"Remove R3 Plate for incubation" message	
14	"Replace both basin liners" message	
15	"Reload R3 Plate on Deck B" message	
16	"Pipette R3 Stop in Deck A --" message	
17	Volume change	
18	Add R3 Stop to plate (20 μ L/well)	4.5 min
19	Pool R3 Plate (105 μ L/well)	4.5 min

Section 1.7. Pre-Lysis

MG S1 St7 V3_5

STEPS	ACTION	DURATION
1	Initial Volumes	
2	"Move Basin Holder to Deck B" message	
3	"Load cell strainer on 10 mL tube" message	
4	Wash basin	30 sec
5	Volume change	
6-12	Strain cells (~7.7 mL)	3.5 min
13	"Move Basin Holder to Deck A" message	
14	"Remove cell strainer - -" message	
15	Add Spin Additive (70 µL)	30 sec
16	"Remove 10mL tube from Deck C" message	
17	"Load 10 mL tube on Deck C --" message	
18	Volume change	
19-23	Remove supernatant (~8 mL)	4 min
24	"Checkpoint: Supernatant Removed--" message	
25-26	Resuspend Pre-Lyse (4 mL)	2 min
27	"Remove 10mL tube from Deck C" message	
28	"Load 10 mL tube on Deck C --" message	
29	Volume change	
30-34	Remove supernatant (~4.4 mL)	2.5 min
35	"Checkpoint: Supernatant Removed - -" message	
36	"Count cells/nuclei" message	

Section 1.8. Lysis and Sublibrary Generation

MG S1 St8 V3_5

STEPS	ACTION	DURATION
1	Initial Volumes	
2-5	Aliquot 25 μ L of sample	4 min
6	Lysis Mastermix	1.5 min
7	Mix Lysis Mastermix	1 min
8	Add Lysis Mastermix to sample (30 μ L)	10 min
9	"remove PCR tubes from Deck C" message	

Section 2.1. Reagent Plating

MG S2 St1 V3_5

STEPS	ACTION	DURATION
1	Initial Volumes	
2	Dispense Streptavidin Beads (88 μ L/well)	2 min
3	Dispense SPRI Beads (160 μ L/well)	1 min
4	Dispense Binding Buffer (110 μ L/well)	2 min
5-7	Dispense Bead Wash Buffer (entire volume)	1 min
8	"Thaw Lysates" message	
9-12	Dispense Wash Buffer 1 (entire volume)	1.5 min
13-17	Dispense Wash Buffer 2 (entire volume)	1.5 min
18	"Load Wash 3-" - message	
19-22	Dispense Wash Buffer 3 (entire volume)	1.5 min
23	"Load Lysates-" message	
24	Enhancer Addition	9 min
25	"Cap and store SPRI beads at RT" message	
26	"Proceed immediately to S2 St2" message	

Section 2.2. cDNA Capture

MG S2 St2 V3_5

STEPS	ACTION	DURATION
1	Initial Volumes	
2	Raise magnet	
3-4	Mix Lysates	1 min
5-7	Remove Streptavidin Bead Supernatant (entire volume)	3 min
8-15	1st Bead Wash (100 μ L/well)	4.5 min
16-23	2nd Bead Wash (100 μ L/well)	4.5 min
24-31	3rd Bead Wash (100 μ L/well)	4.5 min
32-33	Add Binding Buffer and Mix (110 μ L/well)	3 min
34-37	Add Streptavidin Beads to Sample (50 μ L/well)	1 min
38	"Vortex at 800-1k rpm for 30 mins" message	

Section 2.3. Streptavidin Beads Wash

MG S2 St3 V3_5

STEPS	ACTION	DURATION
1	Initial Volumes	
2-6	Supernatant Removal (entire volume)	3.5 min
7-15	1st Wash 1 (120 μ L/well)	8 min
16-24	2nd Wash 1 (120 μ L/well)	8 min
25-32	Wash 2 (120 μ L/well)	8 min

STEPS	ACTION	DURATION
33-34	Wash 3 (120 μ L/well)	1 min
35	"Proceed immediately to S2 St4" message	

Section 2.4. Master Mixes Preparation

MG S2 St4 V3_5

STEPS	ACTION	DURATION
1	Initial Volumes	
2-5	cDNA Amp Mix Prep: Enzyme: 1050 μ L Primer: 1050 μ L	2.5 min
6	Dispense cDNA Amp Mix to Strip Tubes (230 μ L/well)	1 min
7	"Cap and store cDNA Amp on ice—" message	
8-13	Template Switch Mix Prep: Buffer: 1710 μ L (total) Enzyme: 92.4 μ L Primer: 26.2 μ L	5 min
14	Dispense Template Switch to Strip Tubes (220 μ L/well)	1.5 min
15	"Proceed immediately to S2 St5" message	

Section 2.5. Template Switch and cDNA Amplification

MG S2 St5 V3_5

STEPS	ACTION	DURATION
1	Initial Volumes	
2-6	Remove Wash 3 Supernatant (entire volume)	4 min
7-10	Adds Template Switch Mix to Samples (100 μ L/well)	4.5 min
11	"Manually Mix Samples" message	
12	"Seal and incubate at RT for 30 mins" message	
13	"Reload samples on Deck C-" message	
14-17	Mix samples	2 min
18	"Cap and run TS on thermocycler" message	
19	"Reload samples on Heatmag-" message	
20-24	Remove Template Switch Supernatant (entire volume)	3.5 min
25-27	Wash 3 (120 μ L/well)	1.5 min
28	"Load Amp Mix on Deck B-" message	
29-32	Remove Wash 3 Supernatant (entire volume)	2.5 min
33-36	Add cDNA Amp Mix to Sample (100 μ L/well)	4.5 min
37	"Manually Mix Samples" message	
38	"Run cDNA Amp on the Thermocycler" message	

Section 2.6. Post-Amplification Purification

MG S2 St6 V3_5

STEPS	ACTION	DURATION
1	Initial Volumes	
2-3	Mix Samples	1 min
4	Activate Magnet	
5-6	Mix SPRI Beads	2 min
7-9	Transfer Sample (Col 1 & 3) to Tubes (Col 5 & 7) on Heatmag (90 μ L/well)	2 min
10-15	Add SPRI Beads to Samples (72 μ L/well)	9.5 min
16-22	Remove Supernatant (entire volume)	6 min
23-33	1st EtOH Wash (120 μ L/well total)	4.5 min
34-45	2nd EtOH Wash (120 μ L/well total)	6.5 min
46-57	Elution (25 μ L/well)	15 min
58	"Samples on Heatmag Column 9-11" message	

Section 3.0. cDNA Normalization

MG S3 St0 V3_5

STEPS	ACTION	DURATION
1	Initial Volumes	
2	Normalize samples	12.5 min

Section 3.1. SPRI Bead Plating

MG S3 St1 V3_5

STEPS	ACTION	DURATION
1	Initial Volumes	
2	Plate out beads into columns 1 & 3 (50 μ L/well)	2 min
3	Plate out beads into column 2 (90 μ L/well)	1 min
4	Plate out beads into columns 4 & 6 (50 μ L/well)	2 min
5	Plate out beads into column 5 (90 μ L/well)	1 min

Section 3.2. Fragmentation Mix Creation and Plating

MG S3 St2 V3_5

STEPS	ACTION	DURATION
1	Initial Volumes	
2	Pre-chill thermal cycler message	
3	Create Fragmentation Mix	4 min
4	Plate out Fragmentation Mix into column 11 (30 μ L/well)	2 min
5	Proceed to S3 St3 message	

Section 3.3. Fragmentation Mix Addition and Post-Fragmentation SPRI Cleanup

MG S3 St3 V3_5

STEPS	ACTION	DURATION
1	Initial Volumes	
2-3	Stamp Fragmentation Mix into samples (15 μ L/well)	1.5 min
4-8	Deck loading messages	

STEPS	ACTION	DURATION
9	Volume change	
10	Ensure magnet is deactivated	
11-12	Mix SPRI beads	2 min
13-14	Add SPRI beads to samples (30 μ L/well)	2 min
15	5 minute bead incubation	5 min
16	Activate magnet	
17	2 minute bead immobilization	2 min
18-19	Transfer supernatant (75 μ L/well)	1 min
20	Deactivate magnet	
21-22	Add SPRI beads to samples (10 μ L/well)	2 min
23	5 minute bead incubation	5 min
24	Activate magnet	
25	3 minute bead immobilization	3 min
26	Volume change	
27-28	Discard supernatant	1.5 min
29-32	Ethanol addition 1 (180 μ L/well total)	2 min
33	1 minute ethanol incubation	1 min
34-37	Discard ethanol	3 min
38-41	Ethanol addition 2 (180 μ L/well total)	2 min
42	1 minute ethanol incubation	1 min
43-46	Discard ethanol	3 min
47	Deactivate magnet	
48-49	Resuspend beads in water (50 μ L/well)	30 sec
50-55	Offset mixing to ensure full resuspension	2 min

STEPS	ACTION	DURATION
56	5 min bead incubation	5 min
57	Activate Magnet	
58	2 minute bead immobilization	2 min
59-60	Transfer eluate (50 μ L/well)	1 min
61	Deactivate magnet	

Section 3.4. Ligation Mix Creation and Plating

MG S3 St4 V3_5

STEPS	ACTION	DURATION
1	Initial Volumes	
2	Create Ligation Mix	6 min
3	Slow mix to reduce volume stuck in tip	18 sec
4	Plate out Ligation Mix into column 10 (104 μ L/well)	1 min
5	Proceed to S3 St5 message	

Section 3.5. Ligation Mix Addition and Post-Ligation SPRI Cleanup

MG S3 St5 V3_5

STEPS	ACTION	DURATION
1	Initial Volumes	
2-3	Stamp Ligation Mix into samples (50 μ L/well)	2 min
4-6	Deck loading messages	
7	Ensure magnet is deactivated	
8-9	Mix SPRI beads	1.5 min
10-11	Add SPRI beads to samples (80 μ L/well)	3 min

STEPS	ACTION	DURATION
12	5 minute bead incubation	5 min
13	Activate magnet	
14	5 minute bead immobilization	5 min
15	Volume change	
16-19	Discard supernatant	2.5 min
20-23	Ethanol addition 1 (180 µL/well total)	2 min
24	1 minute ethanol incubation	1 min
25-28	Discard ethanol	3.5 min
29-32	Ethanol addition 2 (180 µL/well total)	2 min
33	1 minute ethanol incubation	1 min
34-37	Discard ethanol	3.5 min
38	Air dry delay	1 min
39	Deactivate magnet	
40-41	Resuspend beads in water (23 µL/well)	1.5 min
42	5 minute bead incubation	5 min
43	Activate magnet	
44	2 minute bead immobilization	2 min
45-46	Transfer eluate (21 µL/well)	1 min
47	Deactivate magnet	

Section 3.6. Barcoding Round 4

MG S3 St6 V3_5

STEPS	ACTION	DURATION
1	Initial Volumes	

STEPS	ACTION	DURATION
2	Plate out Amplification Mix into column 9 (55 μ L/well)	1 min
3	Add UDIs message	
4	Proceed to S3 St 7 message	

Section 3.7. Library Amp Mix Addition and Size Selection

MG S3 St7 V3_5

STEPS	ACTION	DURATION
1	Initial Volumes	
2-3	Stamp Amplification Mix into samples (25 μ L/well)	1.5 min
4-6	Deck loading messages	
7	Ensure magnet is deactivated	
8-11	Mix SPRI beads	2 min
12-13	Add SPRI beads to samples (30 μ L/well)	2 min
14	5 minute bead incubation	5 min
15	Activate magnet	
16	2 minute bead immobilization	2 min
17-18	Transfer supernatant (75 μ L/well)	1 min
19	Deactivate magnet	
20-21	Add SPRI beads to samples (10 μ L/well)	2 min
22	5 minute bead incubation	5 min
23	Activate magnet	
24	3 minute bead immobilization	3 min
25	Volume change	

STEPS	ACTION	DURATION
26-27	Discard supernatant	1.5 min
28-31	Ethanol addition 1 (180 μ L/well total)	2 min
32	1 minute ethanol incubation	1 min
33-36	Discard ethanol	3.5 min
37-40	Ethanol addition 2 (180 μ L/well total)	2 min
41	1 minute ethanol incubation	1 min
42-45	Discard ethanol	3.5 min
46	Deactivate magnet	
47-48	Resuspend beads in water (20 μ L/well)	30 sec
49-54	Offset mixing to ensure full resuspension	1.5 min
55	5 minute bead incubation	5 min
56	Activate magnet	
57	2 minute bead immobilization	2 min
58-59	Transfer eluate (20 μ L/well)	1 min
60	Deactivate magnet	

Appendix C: Troubleshooting

Error warning during the execution of a program

- In case of an error warning, abort the program. Do not press "RUN". Scroll down "Run from step". You can then continue from the error location. This allows to resume directly from the point of error.

Tip Pinching

- Tip pinching may occur when using a newly frozen PCR freezer block for a plate pooling step. Ensure that your PCR Freezer Block has been thawed at room temperature for at least 10 minutes.
- Ensure to apply sufficient pressure when placing the plate onto the frozen PCR freezer block.

Incorrect tip location inputted

- The D-ONE Pipette will check the pipette tips before the step starts. The ASSIST PLUS will display an error warning if a pipette tip is incorrectly detected. Abort and restart the program with the correct tip location input.
- The VIAFLO will check the pipette tip after the step is finished. The ASSIST PLUS will display an error warning if a pipette tip is incorrectly detected. Abort and restart the program with the correct tip location input.

Appendix D: Revision History

Version	Description	Date
1.0	Initial release	April 2024
1.1	Section 1.8.1: Revised reagents storage and handling.	November 2024
1.2	Updated scripts	June 2025
1.3	Section 3.7.7b: Corrected ETOH volume	August 2025
1.4	Section 2.4.7: Revised Master Mix volume	November 2025

Appendix E: Acknowledgements

All graphics were created with [Biorender.com](https://biorender.com).



parsebiosciences.com

support@parsebiosciences.com

